

CONNECTOR AMPLIFIER FOR PROPORTIONAL VALVES (0-10VDC Input Version)

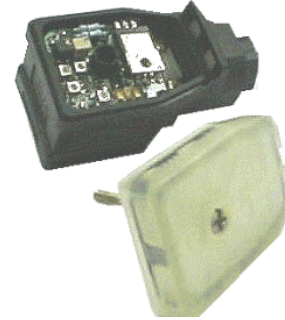

Part No.: CAPV-H-10V-x complete with cable CAPV-S7C-yM

Where: x = current output (2A, 1.2A or 600mA)

y = cable length (2 meters is the standard length)

Function: The Connector Amplifier supplies a solenoid valve with current proportional to an input control (0-10 VDC or 0-20 mA).

Features:

- Maximum current adjustment does not affect minimum current setting
- Adjustments accessible with a removable cover
- Broad range of supply voltage (9 to 28 VDC) with no degradation in performance
- Current sensing circuit maintains output regardless of changes in input voltage and coil resistance
- Modern technology utilizing high frequency switching output (PWM)
- Energy efficient design (no heat sink is required)
- Simple control with 0-10 VDC or 0-20 mA signal inputs
- Options for current output include 2 A, 1.2 A or 600 mA
- Mates to a DIN 43650 plug on a cartridge or block style solenoid valve
- Electronic limiting circuit means no internal fuses
- Short circuit proof (in case of solenoid failure or miswiring)
- Reverse polarity protection
- IP67 weather resistance
- CE certified for EMC
- Can disconnect load while unit is powered ("Hot Swap")

Application: Accurate control of hydraulic and pneumatic proportional solenoid valves used in mobile construction equipment and industrial processes.

Description: The 0-10 V Connector Amplifier simplifies control of proportional solenoids by supplying a current proportional to an input control (0-10 V or 0-20 mA). It accepts power supply voltages from 9 to 28 VDC. This linear solenoid driver utilizes high frequency switching output (PWM) to provide a DC current output. The options for maximum current output include 2 A, 1.2 A or 600 mA. A current sensing circuit maintains output current regardless of changes in input voltage and coil resistance. The user can adjust maximum and minimum current. Ramp time, dither frequency and amplitude can also be adjusted to match the application. The unit is available with a DIN 43650 connection to mount directly on the coil. Other versions are available with 4-20 mA or 0-5 V (including 0-20 mA and 10K potentiometer) inputs. A remote mount version is housed in a rugged metal box.

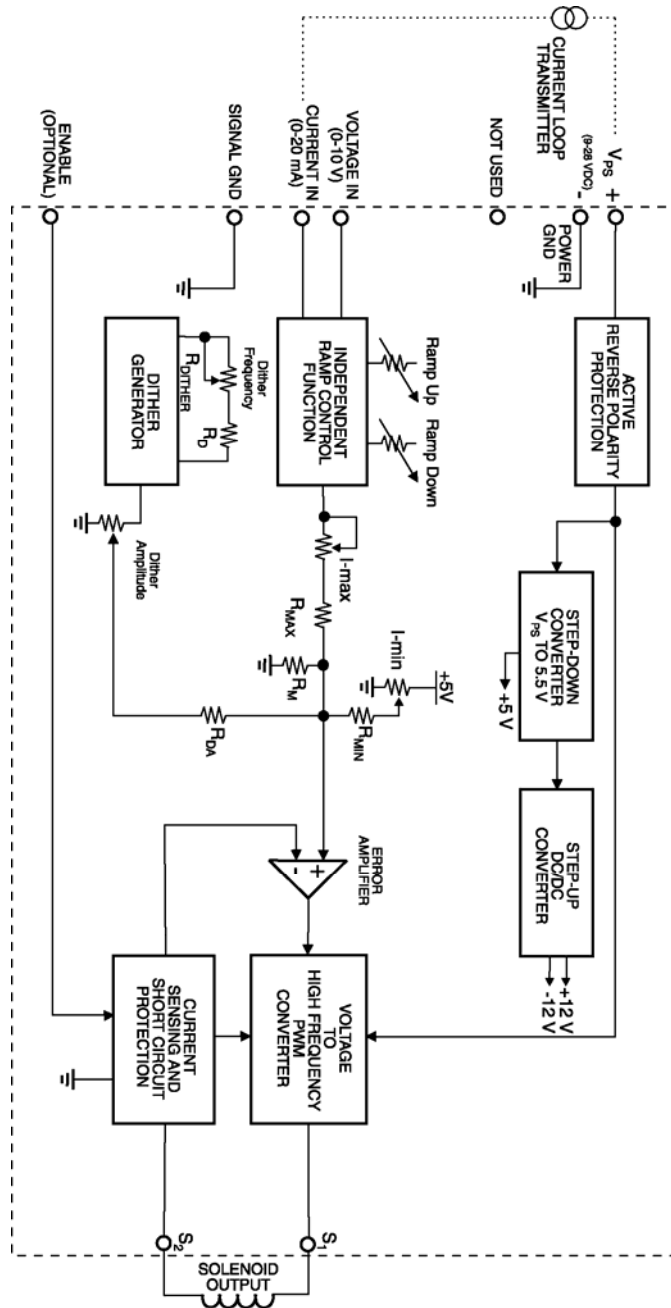

1.0 Technical Specifications:

All specifications typical at nominal input voltage and 25°C unless otherwise specified.

General Specifications

Operating conditions	-40 to +85°C (-40 to 185°F) 0 to 85% relative humidity
Storage temperature	-50 to 125°C (-58 to 257°F)
Weight	0.50 lbs. (0.23 kg)
Electromagnetic compatibility (EMC)	Emission EN 50081-2; Immunity EN 50082-2
Approvals	CE
Electrical connection	DIN 43650 plug and 2 metres jacketed cable (2 conductors 18 AWG, 5 conductors 24 AWG) <i>(Remote mount version with cable available)</i>
Protection class	IP67 when correctly installed with lid, o-ring, washer and base gasket

Dimensions in mm/inches (excluding cable)

Length L1	85.35mm	3.36"
L2	61.75mm	2.43"
L3	34.00mm	1.34"
Width = L3	34.00mm	1.34"
Height H1	38.00mm	1.49"

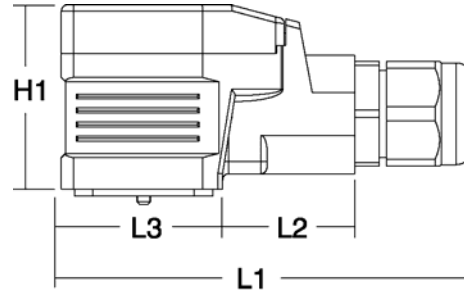

Electrical Specifications

Operating voltage (power supply requirement)	9 to 28 VDC (UL approved range) Accepts up to a maximum of 32 VDC
Control input signal options	0-10 VDC voltage signal or 0-20 mA current signal or 10K potentiometer with external power supply provided by customer <i>(4-20mA or 0-5VDC/0-20mA/10K potentiometer control input versions are also available.)</i>
Input resistance	Voltage mode: 125K Ohms Current mode: 50 Ohms
Range of maximum output current	2 A <i>(1.2 A and 600 mA versions available)</i>
Solenoid resistance selection (nominal)	Nominal resistance of solenoid coil should comply with: $R_{coil} \leq (V_{power\ supply} - 1.5\ V) / I_{max}$

Note 1: For proper operation of the amplifier, match power supply voltage with rating of solenoid coil. Operating the amplifier with a supply voltage lower than the solenoid rated voltage may result in reduced maximum current output.

Note 2: The coil should have no polarity or protection diodes for proper operation of the device.

Note 3: The maximum current output of the amplifier should not exceed the current rating of the solenoid coil.

Adjustments

Minimum current setting	0 to 0.5 A (for 2 A output model) 0 to 0.3 A (for 1.2 A output model) 0 to 150 mA (for 600 mA output model)
Maximum current setting	0.6 to 2.0 A (for 2 A output model) 0.36 to 1.2 A (for 1.2 A output model) 180 to 600 mA (for 600 mA output model)
Current ramp time	0.01 - 5 sec. independent
Dither amplitude	0 to 10% of rated maximum current
Current dither frequency	70 to 350 Hz ($\pm 10\%$ of full scale)

2.0 Installation Procedures:

Housing (Side View)

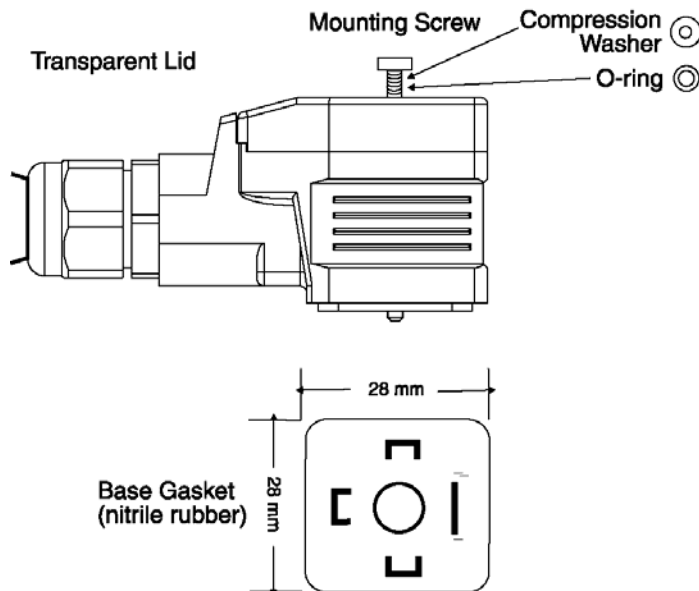

2.1 Precautions Against Leaks From The Environment

- Ensure the transparent lid is firmly in place.
- Ensure the brown rubber base gasket is in place, providing a seal between the Connector Amplifier and the plug on the valve.
- The mounting screw should be flush with the top of the lid with the o-ring and washer in place. Tighten the screw to make a firm connection to the valve with a Phillips #2 screwdriver.

2.2 Necessary Equipment

- Proportional Valve Controller/Amplifier
- Cartridge or Block Proportional Solenoid Valve ready to accept a DIN 43650 plug
- Hydraulic power source and load circuit
- Power Supply (9 to 28 VDC)
- DC voltmeter (optional)
- Choice of Inputs: 0-10 VDC voltage or 0-20 mA current signal or 10K potentiometer with external power supply
- External fusing recommended (3A)

2.3 Installation Steps

- Supply voltage should be between 9 and 28 VDC. Excess voltage will damage the unit. Match the power supply voltage with the voltage rating of the solenoid coil. Operating the controller/amplifier with a supply voltage lower than the solenoid rated voltage may result in reduced maximum current output.
- The maximum current output of the amplifier should not exceed the current rating of the solenoid coil.
- The coil should have no polarity or protection diodes for proper operation of the device.
- Do not install the unit near high voltage relays or other sources of electrical interference.
- Connect the power supply, input signal and valve solenoid as shown below and in Section 2.4. Put isolation sleeves on any unused wires for the input signal.
- Set the input signal to the maximum level and confirm it is operating properly.

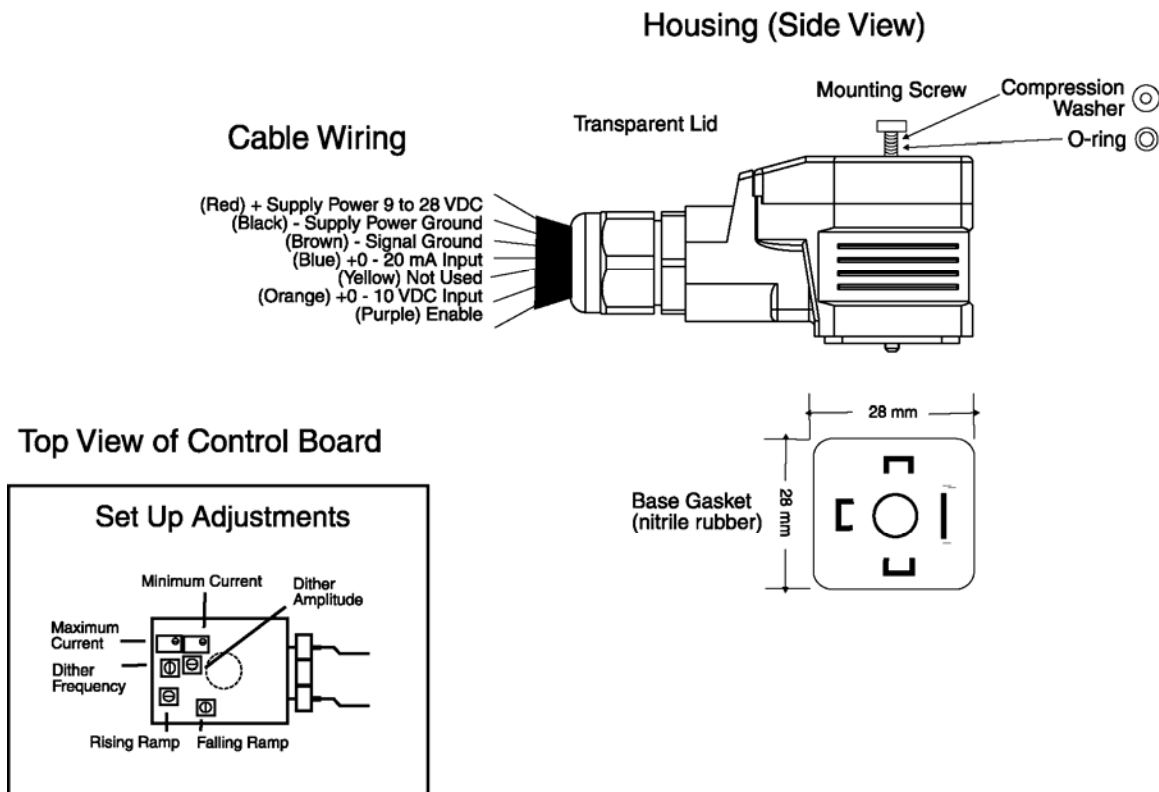

2.4 Wiring Connections

Connect the cable conductors to the power supply and input signal as follows.

For Either 0-20 mA or 0-10 VDC Control:

Turn ramp screws fully counterclockwise to eliminate ramping.

Use I-Min. screw to set up minimum speed with minimum control input.

Use I-Max. screw to set maximum speed with 100% of control input.

For 10K Potentiometer Control:

See diagram below.

Enable:

When Enable is connected to the -ve power supply, the unit will be disabled. When Enable is left open or connected to the +ve power supply, the unit is enabled.

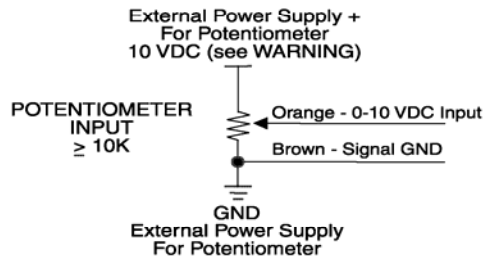
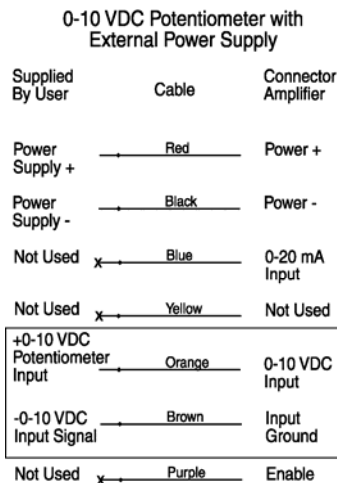
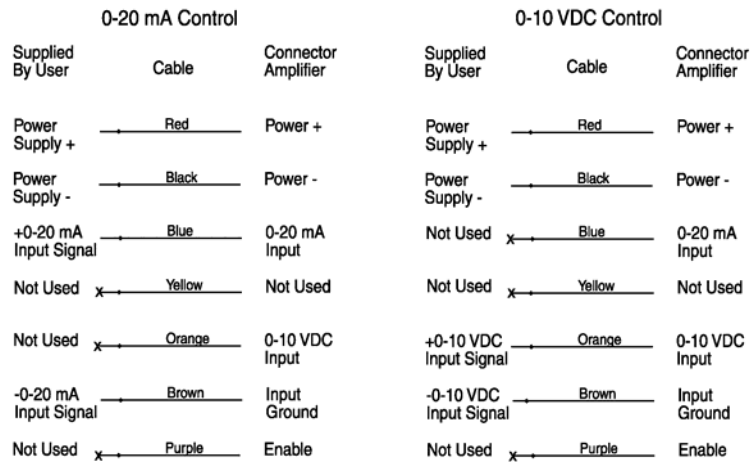

Refer to the diagram above for connection of the Potentiometer to its external power supply and the controller.

WARNING: Input signal must not exceed 10 VDC or damage to the controller may result. High external power supply voltages to the potentiometer must be stepped down to 10VDC.

Refer to page 2 (block diagram) for an alternative method of connecting a current loop transmitter to provide a current control signal input. In this method, the current loop transmitter receives power from the power supply powering the amplifier. The transmitter is connected to the amplifier's +power supply input wire and the +0 to 20mA input wire. This method does not use the - 0 to 20mA input signal wire connection.

3.0 Set Up Adjustment Procedures:

The location of the trim pots for the set up adjustments are shown in Section 2.3.

WARNING: The operator must ensure that the operation of the valve within the full scale of the control function will not cause hazards, while performing set up adjustments to the Connector Amplifier.

3.1 Preparation

Ensure that the Connector Amplifier is connected to an operating proportional valve. Use a small screwdriver to loosen the mounting screw and remove the transparent lid. The trim pots are adjusted with a slotted 1.5 screwdriver.

3.2 Interaction Between Maximum and Minimum Current Adjustments

Adjusting the minimum current will shift the maximum current setting, as shown.

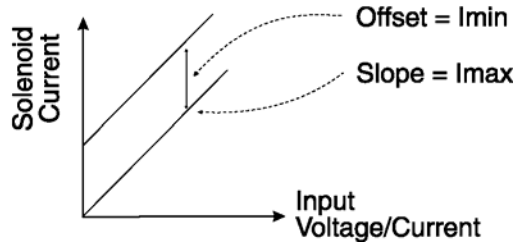

Adjusting the maximum current (I-max.) does not affect the minimum current (I-min.) setting.

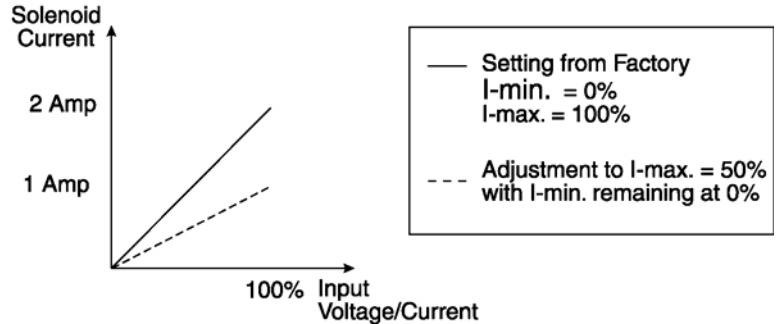

3.3 Connector Amplifier Settings

The following settings represent a typical set up. I min and I max are multi-turn trim pots with a range of 10 turns. Ramp time, dither amplitude and frequency trim pots are single turn. Use a slotted 1.5 screwdriver.

Trim Pot Adjustments	Range of Adjustment	Factory Setting
Zero - Minimum Current Setting (I-min.)	0 to 0.5 A (for 2 A output model) 0 to 0.3 A (for 1.2 A output model) 0 to 150 mA (for 600 mA output model)	0% (CCW)
Span - Maximum Current Setting (I-max.)	0.6 to 2.0 A* (for 2 A output model) 0.36 to 1.2 A (for 1.2 A output model) 180 to 600 mA (for 600 mA output model)	100% (CW)
Ramp Time (Rising & Falling Edge)	0.01 to 5 seconds independent	minimum (0.01 sec.) (CCW)**
Dither Level (Amplitude)	0 to 10% of rated maximum current	0% (CCW)
Dither Frequency	70 to 350 Hz ($\pm 10\%$)	minimum (CCW)

CW = clockwise, CCW = Counterclockwise

*NOTE 1: Range of maximum output current is 2A (maximum output current = minimum current setting + maximum current setting).

**NOTE 2: To eliminate ramping, turn the trim pots fully counter clockwise.

Setting the Minimum Current (I-min.)

- **Set the minimum current before setting the maximum current.**
- Apply minimum input (0 V or 0 A).
- The factory setting for the I-min. trim pot is 0 or fully counter clockwise (CCW).
- If the desired minimum current is greater than 0, adjust the trim pot clockwise (CW) until the desired current is achieved.
- Note: Multi-turn trim pot (10 turns)

The minimum current setting can be used to take into account the mechanical valve deadband and provide desired offsets from zero to allow full control within the functional range of the specific valve.

Setting the Maximum Current (I-max.)

- Apply maximum control (10 V or 20 mA).
- The factory setting for the I-max. trim pot is 100% or fully CW.
- Turn the trim pot CCW to adjust the current setting downwards to the desired maximum.
- Note: Multi-turn trim pot (10 turns)

The maximum current setting is adjusted to meet the customer's working pressure or flow range to the full scale signal input range. This provides maximum control for a specific application.

Setting the Ramp Times

- The factory setting for ramp times is the minimum (0.01 seconds) or fully CCW.
- **If the ramp time settings are not needed, leave the setting at the minimum value.**
- To change the ramp times, adjust the trim pot CW to increase the time.
- Note that rising and falling ramp times are independent.

Ramp times are application dependent. They limit the rate of change or how fast the operation happens. Note that if the input signal is not applied long enough for the ramp time set, the desired solenoid current will not be reached.

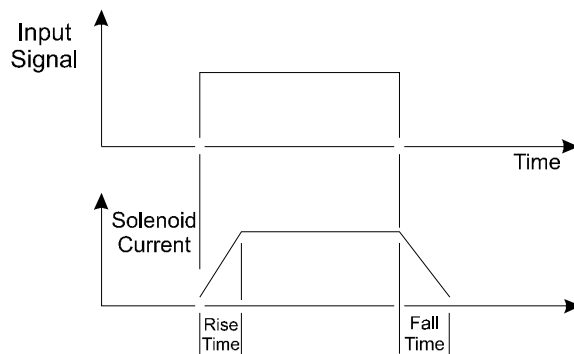

Ramp Times

Setting the Dither Amplitude

- The factory setting for dither amplitude is 0% (CCW).
- To adjust dither amplitude, turn the trim pot CW until small changes in the input signal register similar changes in current output.
- Choose the smallest effective dither amplitude.

Dither amplitude is adjustable from 0 to 10% of the rated maximum current. Dither amplitude and frequency are dependent on the specific valve. The effects of static friction on the operation of the solenoid are reduced by the application of a small AC current. The hysteresis and repeatability of the valve are improved by this practice. The optimum dither amplitude is attained when small input signal changes register similar changes in current output (pressure or flow through the valve).

Setting the Dither Frequency

- The factory setting for dither frequency is the minimum or 0% (CCW).
- To adjust dither frequency, turn the trim pot CW until the desired frequency is set.
- Refer to the proportional valve manufacturer's catalogue for the dither frequency rating of a particular valve.

4.0 Start Up Procedures:

A typical start up procedure is as follows:

1. Ensure the lid, o-ring, washer and base gasket are correctly in place (necessary for IP67 protection).
 2. Ensure that no damage or injury can occur on the machine when the valve is operated.
 3. Attach the Connector Amplifier to the load.
 4. Switch on the power supply to the connector amplifier and apply a control signal.
- Successful completion of these four steps means the Connector Amplifier and load are ready for normal use.

5.0 Operation:

The Connector Amplifier ensures a hydraulic proportional valve will function in a manner directly proportional to the control input. Accurate and repeatable operation is attained. Control of the hydraulic valve occurs with 0-10VDC or 0-20mA signal inputs. The unit performs within the mechanical limits of the proportional valve. No maintenance of the unit is required.

6.0 Repair/Replacement:

The Connector Amplifier contains no serviceable components. Please do not disassemble the unit. **Tampering will void the product warranty.** The product will be replaced or repaired on a "return to factory" basis.

7.0 Ordering Part Number:

CAPV-H-10V-x complete with cable CAPV-S7C-yM

Where: x = current output (2A, 1.2A or 600MA)
y = cable length (2 meters is the standard length)

Specifications are subject to change without notice.
Form: TD1101AX-11/15/07