

# Connector Amplifier For Proportional Valves (4-20 mA input, fixed dither, without ramps) P/N: CAPVE-H-4-20MA-2A-4C-2M



**Function:** The amplifier supplies a solenoid valve with current proportional to an input control (4-20 mA).

**Application:** Accurate control of hydraulic and pneumatic proportional solenoid valves used in mobile construction equipment and industrial processes.

## Features:

- Maximum current adjustment does not affect minimum current setting
- Adjustments accessible with a removable cover
- Broad range of supply voltage (9 to 32 VDC) with no degradation in performance
- Current sensing circuit maintains output current regardless of changes in input voltage and coil resistance
- Modern technology utilizing high frequency switching output (PWM)
- Energy efficient design (no heat sink is required)
- Accepts a 4-20 mA input control signal
- Maximum current output of 2 Amps
- Mates to a DIN 43650 plug on a cartridge or block style solenoid valve
- Electronic limiting circuit means no internal fuses
- Short circuit proof (in case of solenoid failure or miswiring)
- Reverse polarity protection
- IP65 protection rating
- CE approvals
- Can disconnect load while amplifier is powered ("Hot Swap")

## Description:

The Economy Amplifier simplifies control of proportional solenoids by supplying a current proportional to an input control (4-20 mA). It accepts power supply voltages from 9 to 32 VDC. This linear solenoid driver utilizes high frequency switching output (PWM) to provide a DC current output. Maximum current output is 2 Amps. A current sensing circuit maintains output current regardless of changes in input voltage and coil resistance. The user can adjust maximum and minimum current to suit the application. Dither frequency and amplitude are factory set. In this economy version of the connector amplifier there are no ramps. The unit is available with a DIN 43650 connection to mount directly on the coil and comes complete with a 2 meter unterminated cable.

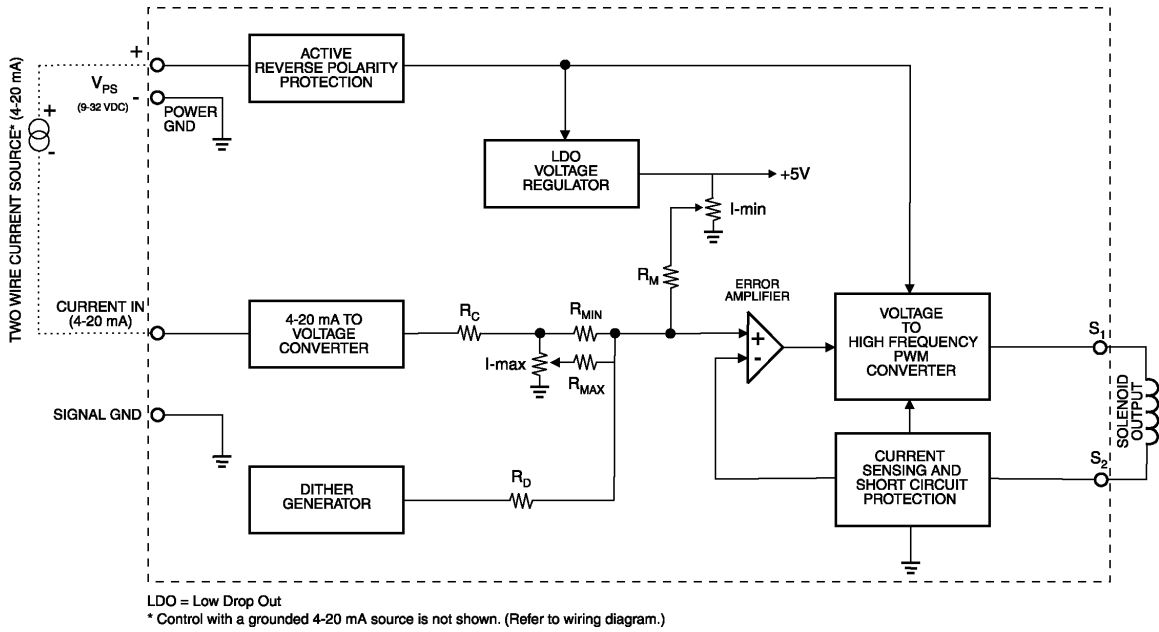

## Technical Specifications:

All specifications typical at nominal input voltage and 25°C unless otherwise specified.

## General Specifications

Operating conditions	-40 to +85°C (-40 to 185°F) 0 to 85% relative humidity
Storage temperature	-50 to 125°C (-58 to 257°F)
Electromagnetic compatibility (EMC)	Emission EN 50081-2 Immunity EN 50082-2
Approvals	CE
Electrical connection	DIN 43650 plug and 2 metres jacketed cable (5 conductors 18 AWG)
Protection class	IP65 when correctly installed with lid, washer, o-ring and base gasket

## Dimensions in mm/inches (excluding cable)

Length L1	85.35 mm	3.36"
L2	61.75 mm	2.43"
L3	34.00 mm	1.34"
Width = L3	34.00 mm	1.34"
Height H1	38.00 mm	1.49"

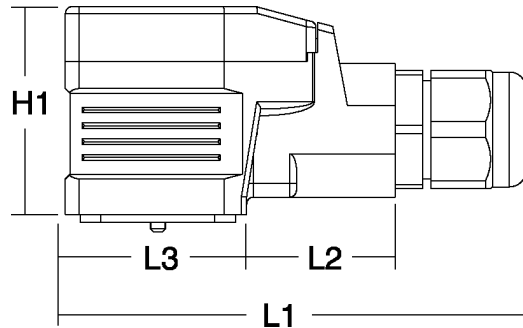

## Electrical Specifications

Operating voltage (power supply requirement)	9 to 32 VDC power supply range
Control input signal	4-20 mA
Input resistance	50 Ohms
Range of maximum output current	2 Amps
Response time	<10 mSec.
Solenoid resistance selection (nominal)	$R_{coil} \leq (V_{power\ supply} - 1.5\ V)/I_{max}$
Current dither frequency	90 Hz ( $\pm 10\%$ of full scale)
Dither amplitude	5% of rated maximum current (fixed)

- \* Note 1: For proper operation, match the power supply voltage with rating of solenoid coil. Operation with a supply voltage lower than the solenoid rated voltage may result in reduced max. current output.  
 Note 2: The coil should have no polarity or protection diodes for proper operation of the device.  
 Note 3: Do not exceed the current rating of the solenoid coil with the maximum current output of the driver.

## Adjustments (single turn trim pots)

Minimum current setting	0 to 500 mA
Maximum current setting	600 to 2000 mA

Specifications are subject to change without notice.

## Installation Procedures:

### Precautions Against Leaks From The Environment

- Ensure the transparent lid is firmly in place.
- Ensure the brown rubber base gasket is in place, providing a seal between the amplifier and the plug on the valve.
- The mounting screw with o-ring and washer in place should be flush with the top of the lid and fastened in place. Tighten the screw to make a firm connection to the valve with a Phillips #2 screwdriver.

### Housing (Side View)

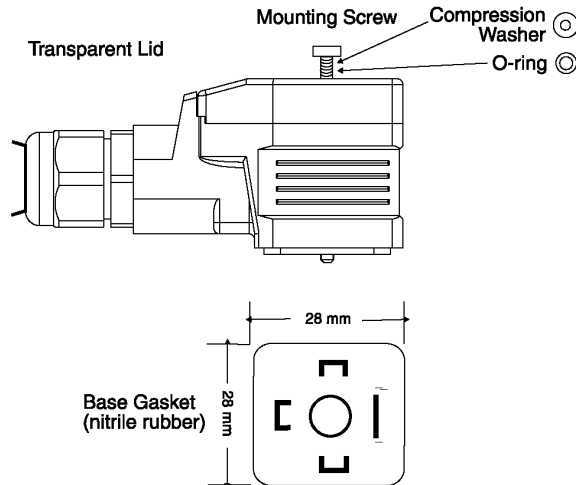

## Necessary Equipment

- Economy Amplifier for Proportional Valves
- Cartridge or Block Proportional Solenoid Valve ready to accept a DIN 43650 plug
- Hydraulic power source and load circuit
- Power Supply (9 to 32 VDC)
- DC voltmeter (optional)
- Control input of 4-20 mA
- External fusing recommended (3 A)

## Installation Steps

- Supply voltage should be between 9 and 32 VDC. Excess voltage will damage the amplifier. Match the power supply voltage with the voltage rating of the solenoid coil. Operating the amplifier with a supply voltage lower than the solenoid rated voltage may result in reduced maximum current output. The maximum current output of the amplifier should not exceed the current rating of the solenoid coil.
- The coil should have no polarity or protection diodes for proper operation of the device.
- Do not install the amplifier near high voltage relays or other sources of electrical interference.
- Connect the power supply, input signal and valve solenoid as shown on the next page. Put isolation sleeves on any unused wires.
- Set the current signal to the maximum level and confirm it is operating properly.

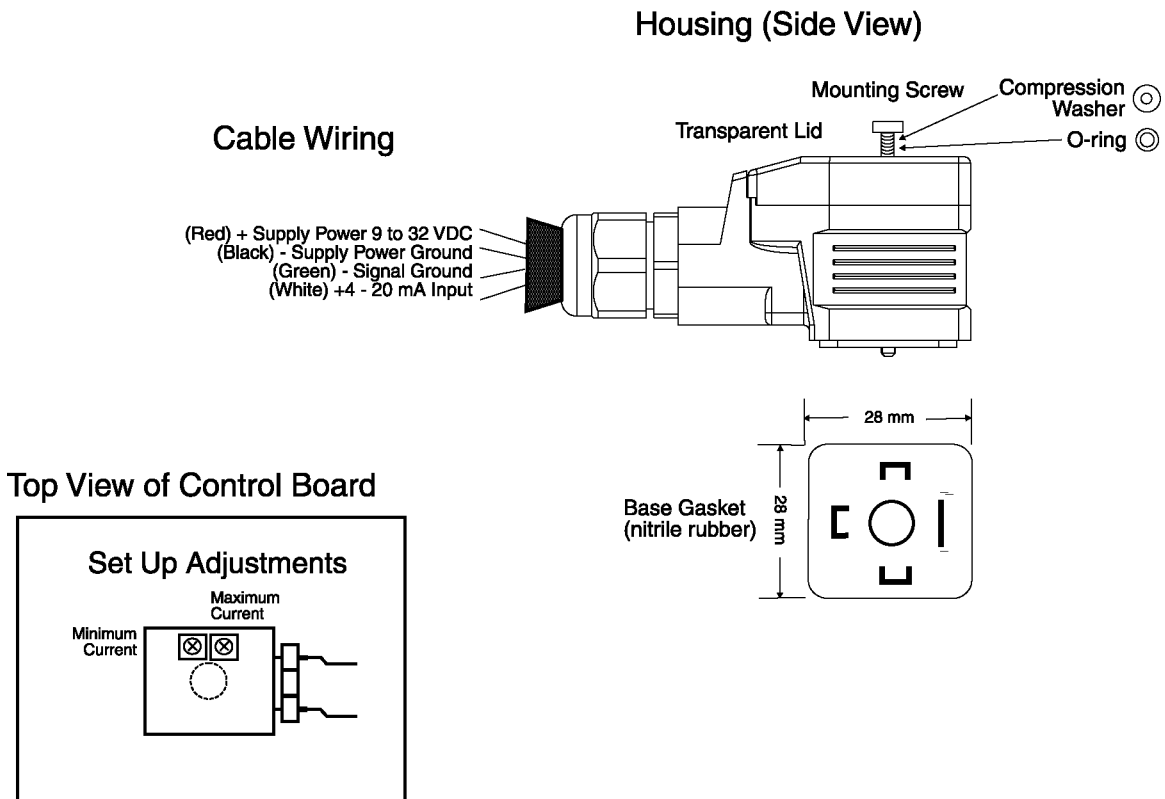

## Wiring Connections

Connect the cable conductors to the power supply and input signal, as follows.

For 4-20 mA Control:

Use I-Min. screw to set up minimum speed with minimum control input.

Use I-Max. screw to set maximum speed with 100% of control input.

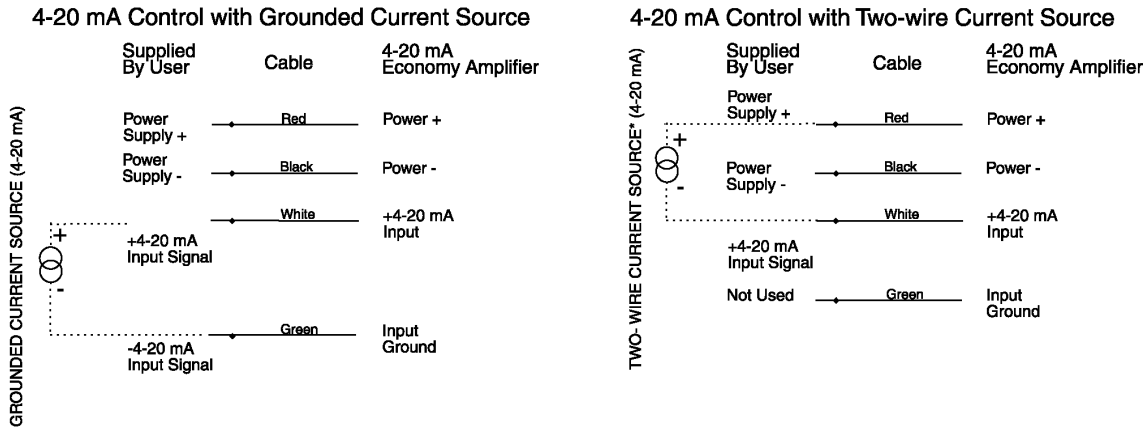

## Set Up Adjustment Procedures:

The location of the trim pots for the set up adjustments are shown under "Installation Steps".

## Preparation

Ensure that the amplifier is connected to an operating proportional valve.

Use a small screwdriver to loosen the mounting screw and remove the transparent lid.

The single turn trim pots are adjusted with a Phillips #0 screwdriver.

## Interaction Between Maximum and Minimum Current Adjustments

Adjusting the minimum current will shift the maximum current setting, as shown.

Adjusting the maximum current (I-max.) does not affect the minimum current (I-min.) setting.

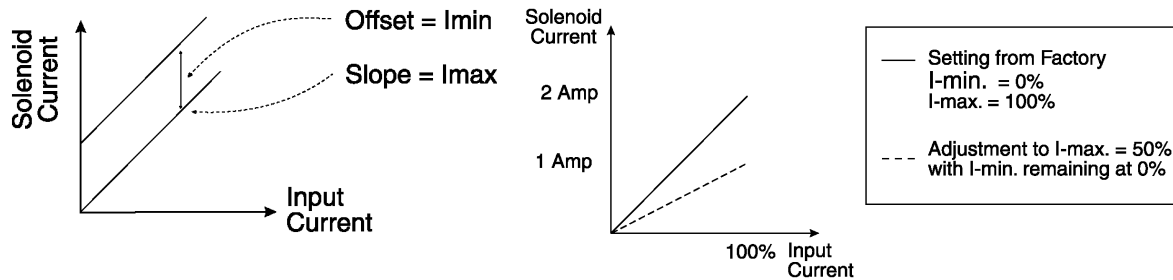

## Amplifier Settings

The following settings represent a typical set up for a current signal input operation scenario.

Conditions will vary for other set up scenarios. I min and I max are single turn trim pots. Use a Phillips#0 screwdriver.

Trim Pot Adjustments	Range of Adjustment	Factory Setting
Minimum Current Setting (I-min.)	0 to 500 mA	0% (CCW)
Maximum Current Setting (I-max.)	600 to 2000 mA*	100% (CW)

CW = clockwise, CCW = Counter clockwise

\* NOTE 1: Range of max. output current is 2 A (maximum output current = minimum current setting + maximum current setting).

### **Setting the Minimum Current (I-min.)**

- **Set the minimum current before setting the maximum current.**
- Apply minimum input (4 mA).
- The factory setting for the I-min. trim pot is 0 or fully counter clockwise (CCW).
- If the desired minimum current is greater than 0, adjust the trim pot clockwise (CW) until the desired current is achieved.

The minimum current setting can be used to take into account the mechanical valve deadband and provide desired offsets from zero to allow full control within the functional range of the specific valve.

### **Setting the Maximum Current (I-max.)**

- Apply maximum control (20 mA).
- The factory setting for the I-max. trim pot is 100% or fully CW.
- Turn the trim pot CCW to adjust the current setting downwards to the desired maximum.

The maximum current setting is adjusted to meet the customer's working pressure or flow range to the full scale signal input range. This provides maximum control for a specific application.

### **Start Up Procedures:**

A typical start up procedure is as follows:

1. Ensure the lid, o-ring, washer and base gasket are correctly in place (necessary for IP65 protection).
2. Ensure that no damage or injury can occur on the machine when the valve is operated.
3. Attach the amplifier to the load.
4. Switch on the power supply to the amplifier and apply a control signal.
5. Adjust the minimum and maximum current to suit the application.

Successful completion of these five steps means the amplifier and load are ready for normal use.

### **Ordering Part Number:**

DIN coil mount, 4-20 mA input, 2 Amp output, 2 meter cable: ***CAPVE-H-4-20MA-2A-4C-2M***

Form: TD1109AX-10/10a/03