

TECHNICAL DATASHEET #TDAX020503  
**QUAD VALVE CONTROLLER with SAE J1939**  
P/N: AX020503

*Multiple Digital, Analog or PWM Command Inputs  
4 Independent Proportional Outputs and 1 On/Off Output  
CAN (SAE J1939)*

**with Electronic Assistant®** 

**Description:**

The quad valve controller provides precise, repeatable control of 4 proportional solenoids and 1 on/off solenoid over a SAE J1939 network. PWM signal inputs or analog voltage or current inputs are accepted for interface to a PLC, Engine Control Module or command potentiometers. Multiple switched inputs are provided to suit a range of applications. Each can be configured to measure the input value, and send the data to a SAE J1939 CAN network. In addition, any output on the controller could be configured to use any of the on board inputs as either a control signal or an enable signal, instead of taking the control information from the CAN bus. Diagnostics messages are provided over the CAN network for the status of inputs or outputs. Settings are user configurable via a Windows-based Electronic Assistant® configuration tool interfacing to the controller via an USB-CAN device to suit a wide variety of applications.



**Applications:**

The controller is designed for harsh operating environments.

Typical applications can include:

- Industrial, off-highway (mobile) and marine applications for the control of hydraulic proportional poppet or spool valves
- Interface with a diesel engine's electronic control module PWM signal to drive accessories
- Transmission controls
- Vehicle traction control
- Closed loop control of hydraulic valves (on request)

**Features:**

- Independent outputs for 4 proportional solenoids (0...2A) and 1 on/off valve ( $\leq 5 A$ )
- Provides 2 +5V, 10 mA reference voltages to power input devices
- 6 inputs available from the following:
  - Up to 4 voltage or current analog inputs, 0-5V, 0-10V, 4-20 mA or 0-20 mA
  - Up to 6 digital inputs for interface to switches, etc.
  - Up to 2 PWM signal, pulse or 16-bit counter inputs from sensors or diesel engine ECM's
  - Enable or disable input commands
- Robust 8...36VDC power supply interface with reverse polarity protection
- Thermal overload and overvoltage protection provided
- Operational from -40 to 85°C (-40 to 185°F)
- CAN (SAE J1939) permits networking (or CANopen® in model AX020502)
- Hardware is available as a platform for application-specific software or setpoints
- **Electronic Assistant®**  runs on a Windows operating system for user configuration. An Axiomatic USB-CAN converter links the PC to the CAN bus.
- Rugged IP67 packaging and connectors

## Ordering Part Numbers:

**AX020503**, Quad Controller, SAE J1939

### Accessories:

**PL-DTM06-12SA-12SB** Mating Plug Kit

(The KIT is comprised of: DTM06-12S, DTM06-12SB, 2 W12S and 24 contacts.

The Axiomatic stock # is FG-IOCTRL-19.)

**AX070502 Configuration KIT** includes the following.

USB-CAN Converter P/N: AX070501

1 ft. (0.3 m) USB Cable P/N: CBL-USB-AB-MM-1.5

12 in. (30 cm) CAN Cable with female DB-9 P/N: CAB-AX070501

AX070502IN CD P/N: CD-AX070502, includes: **Electronic Assistant®** software; EA & USB-CAN User Manual

UMAX07050X; USB-CAN drivers & documentation; CAN Assistant (Scope and Visual) software & documentation; and the SDK Software Development Kit.

**NOTE: To order this kit, you need only to specify P/N: AX070502.**

## Block Diagram:

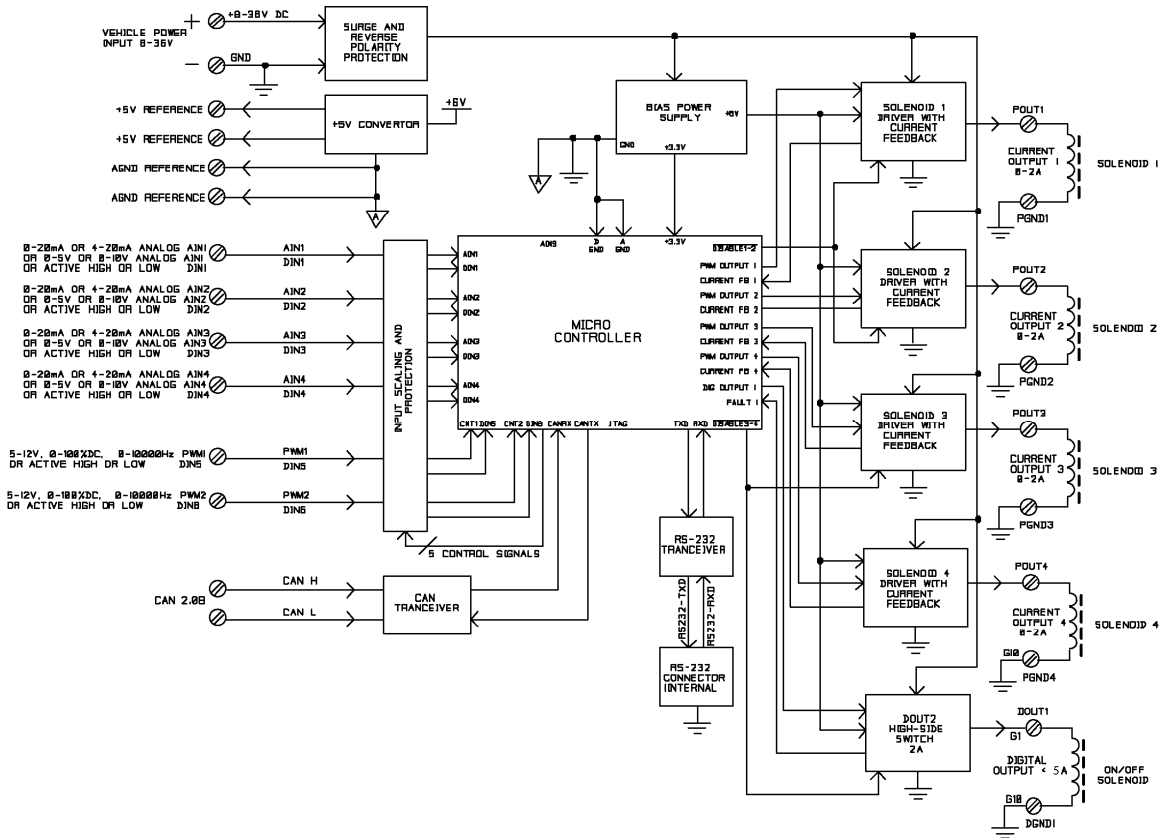

Notes: Model shown above depicts full hardware capability. RS-232 is not available in this model.

## Set up of AX020503 Controller on a CAN Network:

Set up of SAE J1939 Controller on a CAN Network:

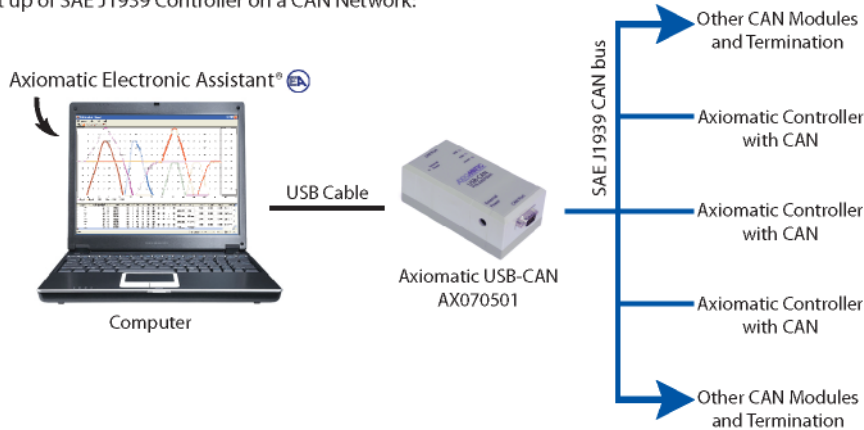

## Technical Specifications:

### Input Specifications (Refer to the block diagram.)

Power Supply Input	12 or 24VDC nominal (8...36 VDC power supply range) NB. The maximum total current draw permitted on the power supply input pins is 6 Amps @ 24VDC, at one time.
Protection	Surge and reverse polarity protection are provided.
All Inputs	Up to 6 inputs are selectable by the user and are arranged as 4 analog and 2 frequency. All inputs, except for frequency and counter, are sampled every 10ms. All inputs operate over the full power supply range of 8...36VDC. Note the current input is limited to a max. of 10V for continuous operation.  With the CAN model, AX020503, all input channels are completely independent of each other as well as can simultaneously control an on-board output and send a message to the J1939 bus. There are six setpoints per channel that are associated with the input and how the data is measured. There are six setpoints per channel that are associated with how the measured input will control a proportional output on the controller. <i>To use the J1939 capabilities, refer to the user manual for details.</i>
Analog Input Configuration	Up to 4 analog inputs are configurable as the following options. <i>Refer to Table 1.0.</i> <ul style="list-style-type: none"> <li>• Disable input</li> <li>• 0...5VDC or 0...10VDC</li> <li>• 4...20mA or 0...20mA</li> <li>• Digital input (8 to 36V)</li> </ul>
Frequency Input Configuration	Up to 2 frequency inputs are configurable as the following options. <i>Refer to Table 1.0.</i> <ul style="list-style-type: none"> <li>• Disable input</li> <li>• PWM signal</li> <li>• Pulse (Hz or RPM)</li> <li>• 16-bit Counter</li> <li>• Digital input (8 to 36V)</li> </ul>
Analog Ground	Two analog ground connections are provided.
Reference Voltages	2 +5V, 10 mA NB. Reference voltages are available if digital inputs are active high. Note: 10 mA is available across pins 8 and 10. Regulation at +/-1% accuracy is provided.
Input Impedance	10 kOhms for all inputs except 0(4)-20 mA which uses a 249 Ohm current sense resistor

Table 1.0 Inputs to AX020503	
Input Type	Description
Disable Inputs	Each input can be configured as a disable input command. When disable is selected, no CAN messages associated with that channel are sent to the network.
Universal Analog Inputs	<p>Up to 4 analog inputs are available.  <b>0...5VDC or 0...10VDC</b>            The offset is in volts and the resolution setpoint is V/bit, when sending a CAN message.            Accuracy of 0-5V input (inputs 1-4) is +/- 50 mV. Accuracy of 0-10V input (1-4) is +/-100 mV.  <b>Error detection setpoints are interpreted in volts.</b>  <b>4...20mA or 0...20mA</b>            The offset is in milliamps and the resolution setpoint is mA/bit, when sending a message.            Accuracy of current input (inputs 1-4) is +/- 0.5 mA.  <b>Error detection setpoints are interpreted in milliamps.</b></p>
Digital Inputs	<p>Up to 6 digital inputs are available.            The input can be configured for either an active high input (switch is connected to a +V signal when ON) or an active low input (switch is connected to a GND signal when ON) using the "DIN Active Level" setpoint. The controller interprets the offset as a state (OFF=0 or ON=1) and the resolution setpoint as state/bit, when sending the message. Error detection setpoints are not used, since error detection is not possible in this mode.</p>
PWM Signal Inputs	<p>Up to 2 PWM inputs are available to interface to a PWM signal from an ECM, PLC or other.  <b>PWM Signal Frequency: 0 – 10,000 Hz</b>  <b>Amplitude: 5-12V</b>  <b>PWM Duty Cycle: 0 to 100%</b>            At <math>\leq 1</math> kHz the input accuracy is +/- 1%. At &gt; 1kHz, it is +/- 5%. (Inputs 5 and 6)            The offset is interpreted as percent duty cycle (%dc) and the resolution setpoint as %dc/bit, when sending the CAN message. Error detection setpoints will be interpreted in %dc.</p>
Pulse Inputs	<p>Up to 2 pulse inputs are available.            This input counts the number of pulses over the period of the measuring window setpoint and calculates the frequency of the pulses.  <b>Hz = With a pulse per revolution of 0, the controller calculates the offset in Hz and the resolution setpoint as Hz/bit, when sending the CAN message. Error detection setpoints are in Hertz.</b>  <b>RPM = With a non-zero pulse per revolution, the frequency is interpreted as a RPM input. The offset is in revolutions per minute (RPM) and the resolution setpoint is RPM/bit. Error detection setpoints are interpreted in RPM.</b>            Accuracy of pulse input (inputs 5,6) is +/- 1%.</p>
16-bit Counter Inputs	<p>Up to 2 16-bit counter inputs are available.            A counter input cannot be used to control an output.            The input is configured to count pulses on the input until the value in the measuring window setpoint is reached. While the counter is active, a timer with a 1ms resolution is running in the background. When the count has been reached, the value in the 1ms timer is captured and updated to the input feedback variable. The timer is reset until the count value once again reaches the measuring window. Input and error detection setpoints are not used, since error detection is not possible in this mode.            Accuracy of counter input (inputs 5,6) is +/- 1%.</p>

## Output Specifications

Proportional Outputs	<p>High side (sourcing), High frequency PWM            The 4 outputs are configurable as proportional or on/off as follows:            Four independent proportional outputs (0...2A)            NB. The maximum total current draw permitted on the power supply input pins is 6 Amps @ 24VDC, at one time.</p> <p>Each output provides a feedback signal to the processor that can be read via the J1939 network for diagnostic purposes. The controller can also detect and flag overcurrent and open circuit loads.</p> <table border="1"> <thead> <tr> <th colspan="2">Table 2.0: Proportional Output Adjustments</th> </tr> <tr> <th>Adjustable Parameter</th> <th>Description</th> </tr> </thead> <tbody> <tr> <td>Output Current Adjustments</td> <td>0- I<sub>max</sub> (2A) Both minimum and maximum current settings are user configurable.</td> </tr> <tr> <td>Superimposed Dither</td> <td>Dither adjustments are configurable for each channel.  <b>Dither Amplitude:</b>            0 mA (factory default)            Adjustable from 0-500 mA  <b>Dither Frequency:</b>            200 Hz (factory default)            Adjustable from 50-400 Hz</td> </tr> <tr> <td>Ramp Rates</td> <td>Ramp adjustments are configurable for each channel.            1,000 mSec (default)            Adjustable from 0 to 10,000 mSec (10 sec.).</td> </tr> </tbody> </table>	Table 2.0: Proportional Output Adjustments		Adjustable Parameter	Description	Output Current Adjustments	0- I <sub>max</sub> (2A) Both minimum and maximum current settings are user configurable.	Superimposed Dither	Dither adjustments are configurable for each channel. <b>Dither Amplitude:</b> 0 mA (factory default) Adjustable from 0-500 mA <b>Dither Frequency:</b> 200 Hz (factory default) Adjustable from 50-400 Hz	Ramp Rates	Ramp adjustments are configurable for each channel. 1,000 mSec (default) Adjustable from 0 to 10,000 mSec (10 sec.).
Table 2.0: Proportional Output Adjustments											
Adjustable Parameter	Description										
Output Current Adjustments	0- I <sub>max</sub> (2A) Both minimum and maximum current settings are user configurable.										
Superimposed Dither	Dither adjustments are configurable for each channel. <b>Dither Amplitude:</b> 0 mA (factory default) Adjustable from 0-500 mA <b>Dither Frequency:</b> 200 Hz (factory default) Adjustable from 50-400 Hz										
Ramp Rates	Ramp adjustments are configurable for each channel. 1,000 mSec (default) Adjustable from 0 to 10,000 mSec (10 sec.).										

Proportional Output Logic	<p>The output current is proportional to the control input signal.</p> <p>For the proportional outputs, there are up to six output profiles that can be selected to determine how the output will react to a change at the input. Refer to the graphs below for details. There are five setpoints per channel that are associated with the output and how it is controlled. There are another seven setpoints that will determine the output's behavior, depending on the profile selected in "Output Response". Refer to the user manual for details.</p> <p>Note 1: For proportional poppet valve applications, a dual slope is user configurable.  Note 2: In digital output mode, the output can be hotshot with a current to turn the load on, and then dropped to a holding current to keep the load on with less energy. The current, at which the output is hotshot, and the length of time it is held at this value, are both configurable, as is the holding current.</p>
Digital Output	<p>High side (sourcing)  One digital output (<math>\leq 5A</math>)</p> <p>The controller will recognize a problem at DOUT, but it cannot distinguish between open or short, so it will simply flag that a fault exists.</p>
Digital Output Logic (for all outputs)	<p>There are five setpoints per channel that are associated with the output and how it is controlled.</p> <p>If an output is controlled by an input NOT configured as a digital input, then the output will respond as per the setting in the "Output Response" setpoint. Refer to the user manual for details.</p> <p>If an On/Off response is selected, an Input is ON when the input is greater than or equal to the Maximum Input setpoint and OFF when the input is less than or equal to the Minimum Input setpoint. Input values between these two limits will have no affect on the state of the input. The output state will equal the input state (Input ON = Output ON).</p> <p>If an Output will be ON or OFF depending on whether an input is inside or outside of its range, the range is determined by the values in the Minimum Deadband and Maximum Deadband setpoints of the input.  (Minimum Deadband <math>\leq</math> Range <math>\leq</math> Maximum Deadband)</p> <p>When a Dual Input response is selected for a digital output, then the Enable Input for that output channel can be used as the second control input. Refer to the user manual for more details.</p>
Output Accuracy	+/-1%
Protection	<p>Overcurrent protection is provided on both proportional and digital outputs.  Short circuit protection is provided on both proportional and digital outputs.</p>
Error Conditions	If an error on the input is detected, the output of the controller shuts off.

### Proportional Output Response Profiles:

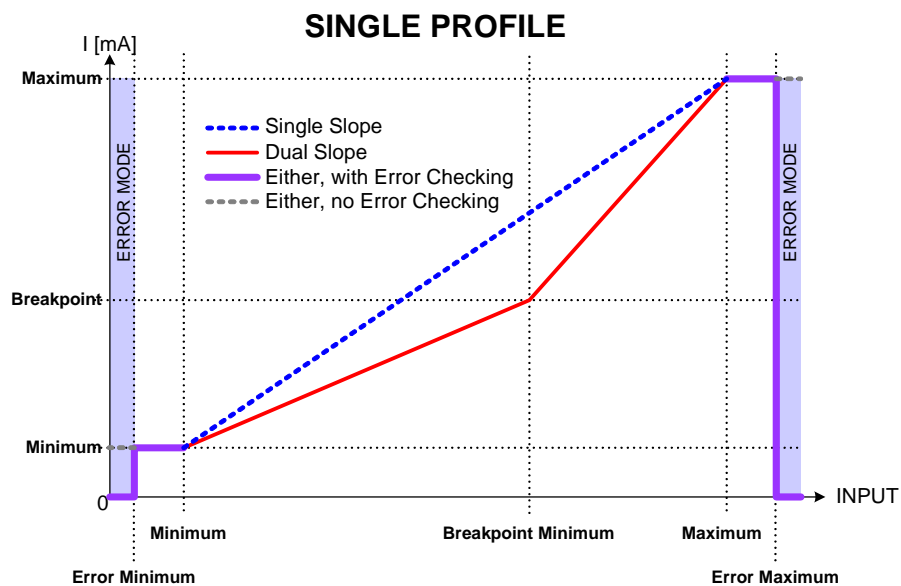

### DUAL PROFILE A

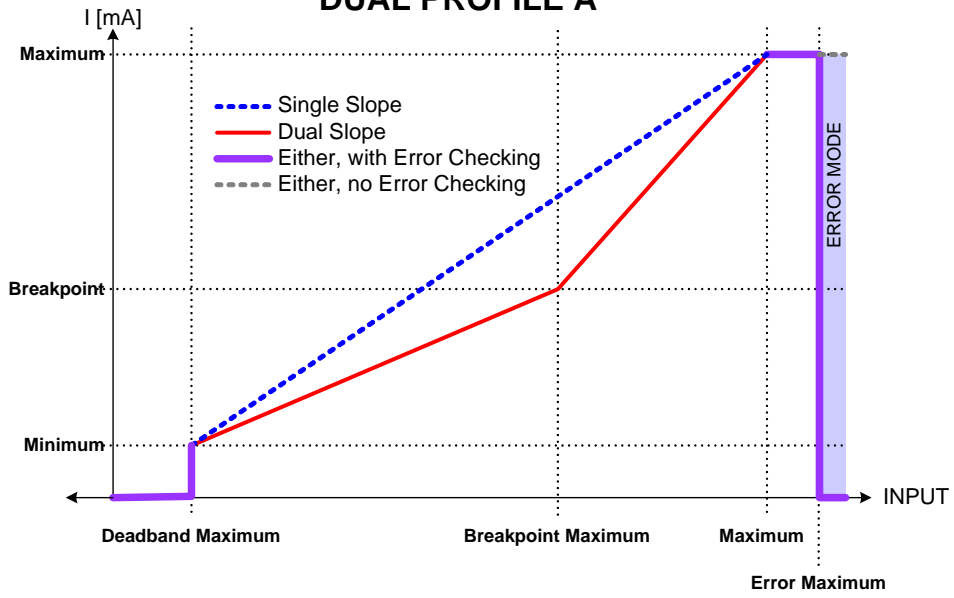

### DUAL PROFILE B

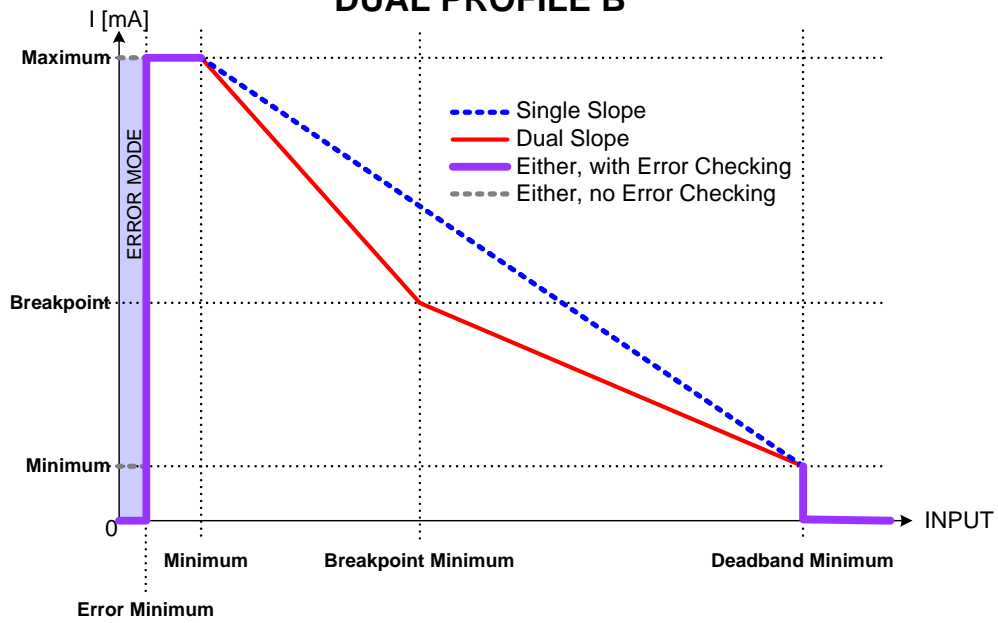

## General Specifications

Operating Conditions	-40 to 85°C (-40 to 185°F)
Weight	0.55 lbs. (0.25 kg)
Protection	IP67; Unit is conformal coated within the housing. Plugs carry an IP69 rating.
Microprocessor	Motorola MC56F8346
Control Logic	Standard embedded software is provided. <i>Refer to the user manual for details.</i> (Application-specific control logic is available on request.)
User Interface	User configuration and diagnostics are provided with the Axiomatic Electronic Assistant®. The Axiomatic Service Tool is a <i>Windows</i> -based graphical user interface that allows easy configuration of the controller setpoints. Refer to Table 3.0 for details.
Network Termination	It is necessary to terminate the network with external termination resistors. The resistors are 120 Ohm, 0.25W minimum, metal film or similar type. They should be placed between CAN_H and CAN_L terminals at both ends of the network.

Table 3.0 - Electronic Assistant®

### Electronic Assistant®

The Electronic Assistant® (EA) runs on any modern PC with the Microsoft Windows® 2000 operating system or higher. It comes with a royalty-free license for use.

#### System Requirements:

Operating System: *Windows* 2000 or higher including 64-bit editions

Port: USB 1.1 or 2.0 full speed

Display: VGA (XGA or better with 1024 x 768 recommended)

Setup and Configuration:

Refer to the User Manual UMAX07050X.

**To order the EA software at the time of initial purchase, order the KIT AX070502 (see above) which includes the Axiomatic USB-CAN converter.** For additional EA and USB-CAN software ONLY CD's, use ordering P/N: CD-AX070502.

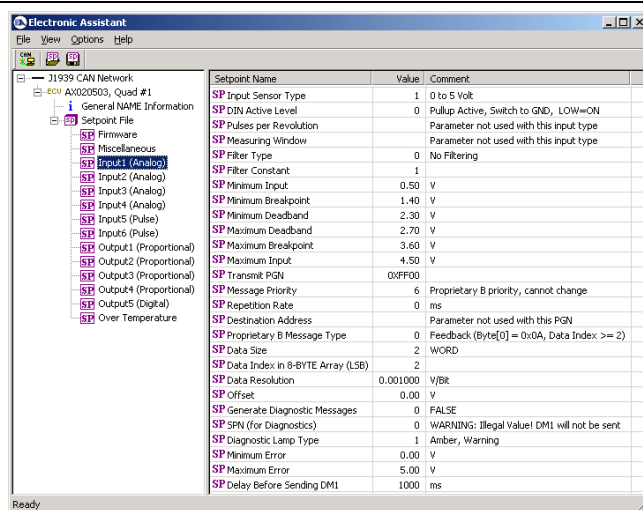

Figure 2.0 Configuration screen from the Electronic Assistant

The Electronic Assistant® (EA) is a software configuration tool that runs on a PC connected to a J1939 bus via a USB to CAN converter, AX070501. Upon being connected to the bus, the EA will find all the Electronic Control Units (ECU) on the bus, and recognized those manufactured by Axiomatic. Using this tool, a user can quickly configure an Axiomatic ECU for the desired performance over a wide variety of applications.

CAN Interface	<p>1 CAN port (SAE J1939)</p> <p>The software was designed to provide flexibility and provides the following.</p> <ul style="list-style-type: none"> <li>• Configurable ECU Instance in the NAME (for multiple ECU's on the network)</li> <li>• Configurable Input Parameters</li> <li>• Configurable Output Parameters</li> <li>• Configurable PGN and Data Parameters</li> <li>• Configurable Diagnostic Messaging Parameters, as required</li> <li>• Diagnostic Log, maintained in non-volatile memory</li> </ul> <p><i>Note: Configurable parameters are also called setpoints.</i></p> <p>Any input or output on the controller by default uses a Proprietary B message to send data to the network bus. There are nine setpoints per channel that are associated with the J1939 message that is sent to the network bus. There are eleven setpoints per channel that are associated with the J1939 command message that is received by the ECU from the network bus. There are six setpoints per input channel, four per output channel, and seven per fault, that are associated with if and how diagnostic messages will be sent to the network bus. <i>To use J1939 capabilities, refer to the user manual.</i></p> <p>The Axiomatic Quad, AX020503, is compliant with Bosch CAN protocol specification, Rev.2.0, Part B, and the following J1939 standards.</p> <table border="1" data-bbox="570 701 1349 1719"> <thead> <tr> <th colspan="2" data-bbox="570 701 1349 737"><i>Table 4: J1939 Compliance</i></th> </tr> <tr> <th data-bbox="570 737 797 793">OSI Network Model Layer</th> <th data-bbox="797 737 1349 793">J1939 Standard</th> </tr> </thead> <tbody> <tr> <td data-bbox="570 793 797 867">Physical</td> <td data-bbox="797 793 1349 867">J1939/11 – Physical Layer, 250K bit/s, Twisted Shielded Pair. J1939/15 - Reduced Physical Layer, 250K bits/sec, Un-Shielded Twisted Pair (UTP).</td> </tr> <tr> <td data-bbox="570 867 797 1045">Data Link</td> <td data-bbox="797 867 1349 1045">J1939/21 – Data Link Layer The controller supports Transport Protocol for Diagnostic DM1 and DM2 messages (PGN 65226 and 65227). It supports responses on PGN Requests (PGN 59904) and acknowledgements (PGN 59392). It also supports Proprietary B messaging (PGN 65280 to 65535), and uses a proprietary scheme described in the User Manual.</td> </tr> <tr> <td data-bbox="570 1045 797 1224">Network Layer</td> <td data-bbox="797 1045 1349 1224">J1939/81 – Network Management J1939, Appendix B – Address and Identity Assignments Arbitrary Address Capable ECU - It can dynamically change its network address in real time. The controller supports: Address Claimed Messages (PGN 60928), Requests for Address Claimed Messages (PGN 59904) and Commanded Address Messages (PGN 65240).</td> </tr> <tr> <td data-bbox="570 1224 797 1719">Application Layer</td> <td data-bbox="797 1224 1349 1719">J1939/71 – Vehicle Application Layer None of the application layer PGN's are supported as part of the default configurations. However, the Quad could be configured such that any of the input messages to be sent will use a PGN from this section, or for the outputs to respond to the data in a message with a PGN from this section. The data size, index, resolution and offset can all be configured for the appropriate SPN associated with the PGN. <i>It is the user's responsibility to configure the Quad such that it will not violate the J1939 standard.</i> J1939/73 – Application Layer – Diagnostics The Quad can be configured to send "Active Diagnostic Trouble Code" DM1 messages (PGN 65226) for any I/O channel. Warning and Protect diagnostics will automatically become previously active when cleared. "Previously Active Diagnostic Trouble Codes" DM2 messages (PGN 65227) are available on request. Shutdown diagnostics will be cleared upon receiving a "Diagnostic Data Clear/Reset for Active DTC's" DM11 message (PGN 65235). Occurrence counts in the diagnostic log will be cleared upon receiving a "Diagnostic Data Clear/Reset for Previously Active DTC's" DM3 message (PGN 65228).</td> </tr> </tbody> </table>	<i>Table 4: J1939 Compliance</i>		OSI Network Model Layer	J1939 Standard	Physical	J1939/11 – Physical Layer, 250K bit/s, Twisted Shielded Pair. J1939/15 - Reduced Physical Layer, 250K bits/sec, Un-Shielded Twisted Pair (UTP).	Data Link	J1939/21 – Data Link Layer The controller supports Transport Protocol for Diagnostic DM1 and DM2 messages (PGN 65226 and 65227). It supports responses on PGN Requests (PGN 59904) and acknowledgements (PGN 59392). It also supports Proprietary B messaging (PGN 65280 to 65535), and uses a proprietary scheme described in the User Manual.	Network Layer	J1939/81 – Network Management J1939, Appendix B – Address and Identity Assignments Arbitrary Address Capable ECU - It can dynamically change its network address in real time. The controller supports: Address Claimed Messages (PGN 60928), Requests for Address Claimed Messages (PGN 59904) and Commanded Address Messages (PGN 65240).	Application Layer	J1939/71 – Vehicle Application Layer None of the application layer PGN's are supported as part of the default configurations. However, the Quad could be configured such that any of the input messages to be sent will use a PGN from this section, or for the outputs to respond to the data in a message with a PGN from this section. The data size, index, resolution and offset can all be configured for the appropriate SPN associated with the PGN. <i>It is the user's responsibility to configure the Quad such that it will not violate the J1939 standard.</i> J1939/73 – Application Layer – Diagnostics The Quad can be configured to send "Active Diagnostic Trouble Code" DM1 messages (PGN 65226) for any I/O channel. Warning and Protect diagnostics will automatically become previously active when cleared. "Previously Active Diagnostic Trouble Codes" DM2 messages (PGN 65227) are available on request. Shutdown diagnostics will be cleared upon receiving a "Diagnostic Data Clear/Reset for Active DTC's" DM11 message (PGN 65235). Occurrence counts in the diagnostic log will be cleared upon receiving a "Diagnostic Data Clear/Reset for Previously Active DTC's" DM3 message (PGN 65228).
<i>Table 4: J1939 Compliance</i>													
OSI Network Model Layer	J1939 Standard												
Physical	J1939/11 – Physical Layer, 250K bit/s, Twisted Shielded Pair. J1939/15 - Reduced Physical Layer, 250K bits/sec, Un-Shielded Twisted Pair (UTP).												
Data Link	J1939/21 – Data Link Layer The controller supports Transport Protocol for Diagnostic DM1 and DM2 messages (PGN 65226 and 65227). It supports responses on PGN Requests (PGN 59904) and acknowledgements (PGN 59392). It also supports Proprietary B messaging (PGN 65280 to 65535), and uses a proprietary scheme described in the User Manual.												
Network Layer	J1939/81 – Network Management J1939, Appendix B – Address and Identity Assignments Arbitrary Address Capable ECU - It can dynamically change its network address in real time. The controller supports: Address Claimed Messages (PGN 60928), Requests for Address Claimed Messages (PGN 59904) and Commanded Address Messages (PGN 65240).												
Application Layer	J1939/71 – Vehicle Application Layer None of the application layer PGN's are supported as part of the default configurations. However, the Quad could be configured such that any of the input messages to be sent will use a PGN from this section, or for the outputs to respond to the data in a message with a PGN from this section. The data size, index, resolution and offset can all be configured for the appropriate SPN associated with the PGN. <i>It is the user's responsibility to configure the Quad such that it will not violate the J1939 standard.</i> J1939/73 – Application Layer – Diagnostics The Quad can be configured to send "Active Diagnostic Trouble Code" DM1 messages (PGN 65226) for any I/O channel. Warning and Protect diagnostics will automatically become previously active when cleared. "Previously Active Diagnostic Trouble Codes" DM2 messages (PGN 65227) are available on request. Shutdown diagnostics will be cleared upon receiving a "Diagnostic Data Clear/Reset for Active DTC's" DM11 message (PGN 65235). Occurrence counts in the diagnostic log will be cleared upon receiving a "Diagnostic Data Clear/Reset for Previously Active DTC's" DM3 message (PGN 65228).												



<p>Diagnostics</p>	<p>Diagnostics messages are provided over the CAN network for the status of inputs or outputs. Each input or output channel could be configured to send diagnostic messages to the network if the I/O goes out of range. In addition to the I/O channels, one other type of fault can be reported to the network using diagnostic messaging, which is an Over Temperature fault (of the controller processor.) The controller stores diagnostic data in a non-volatile log.</p> <p>There are six setpoints per input channel, four per output channel, and seven per fault, that are associated with if and how diagnostic messages will be sent to the network bus. <i>Refer to the user manual for details.</i></p>
<p>Electrical Connections</p>	<p>Refer to Table 5.0.</p> <p>Deutsch DTM series 24 pin receptacle (DTM13-12PA-12PB-R008)</p> <p>Mating plugs kits are available on request and include Deutsch DTM06-12SA and DTM06-12SB with 2 wedgelocks (WM12S) and 24 contacts (0462-201-20141). 20 AWG wire is recommended for use with contacts 0462-201-20141.</p> <p><b>Use dielectric grease on the pins when installing the controller.</b></p> <div style="text-align: center;">  <p><b>Key Arrangement B (black)</b></p> <p><b>Key Arrangement A (grey)</b></p> <p><b>FRONT VIEW 24 PIN RECEPTACLE</b></p> </div>
<p>Packaging and Dimensions</p>	<p>High Temperature Nylon housing, Deutsch IPD PCB Enclosure (EEC-325X4B) 4.62 x 5.24 x 1.43 inches 117.42 x 133.09 x 36.36 mm (W x L x H excluding mating plug)</p> <div style="text-align: center;">  <p><b>HOUSING DIMENSIONS</b> Housing Material: High Temperature Nylon (Black)</p> <p>3D VIEW Housing with 24 Pin Receptacle</p> </div> <div style="display: flex; justify-content: space-around;"> <div style="text-align: center;">  <p><b>BOTTOM VIEW</b></p> <p>4.677 [118.80]</p> <p>1.53 [39.00]</p> <p>5.237 [133.03]</p> <p>4.00 [101.60]</p> <p>Distance between mounting holes</p> <p>Height 1.368 [34.75] with 24 pin receptacle</p> <p>Mounting Holes: <math>\varnothing</math> 0.29 [7.40] through 2 pl for 0.25 [6.00] fastener</p> <p>Mounting flange: 16 mm [0.63 in] thick</p> </div> <div style="text-align: center;">  <p><b>FRONT VIEW 24-PIN RECEPTACLE (NOT TO SCALE)</b></p> <p>3.976 [101.00]</p> <p>Key Arrangement B (black)</p> <p>1.417 [36.00]</p> <p>Key Arrangement A (grey)</p> </div> </div> <p>Mating Plug Assemblies for 24-pin receptacle: Deutsch IPD P/N: DTM06-12SA and DTM06-12SB with wedgelocks WM12S and contacts (Contact factory for contact specification.)</p> <p>Dimensions: inches (mm) excluding mating plug(s)</p>

Table 5.0 – Pin out: AX020503

Grey Connector PIN #	Function	Black Connector PIN #	Function
12	Power -	6	Analog In 4 / Digital In 4
1	Power +	7	Analog GND 2
11	Proportional Solenoid 1-	5	Analog In 3 / Digital In 3
2	Proportional Solenoid 1+	8	+5V Reference 2
10	Proportional Solenoid 2-	4	Analog In 2 / Digital In 2
3	Proportional Solenoid 2+	9	Analog GND1
9	Proportional Solenoid 3-	3	Analog In 1 / Digital In 1
4	Proportional Solenoid 3+	10	+5V Reference 1
8	Proportional Solenoid 4-	2	CAN_L
5	Proportional Solenoid 4+	11	PWM In 1 / Digital In 5 (See Notes.)
7	Digital Solenoid -	1	CAN_H
6	Digital Solenoid +	12	PWM In 2 / Digital In 6 (See Notes.)

Notes: To ground a PWM input, it is recommended to use the analog GND connection pin.  
 Active high digital inputs can be connected to the +5V reference.  
 It is recommended that active low inputs can be grounded to the analog GND connection pin.

Note: CANopen® is a registered community trade mark of CAN in Automation e.V.

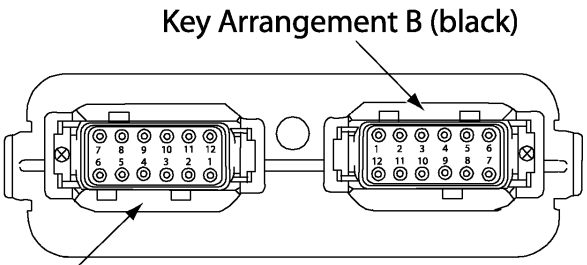
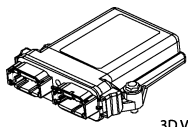
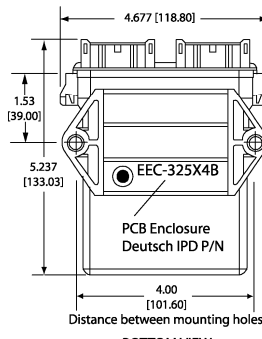
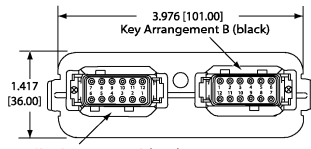
*Specifications are indicative and subject to change. Actual performance will vary depending on the application and operating conditions. Users should satisfy themselves that the product is suitable for use in the intended application. All our products carry a limited warranty against defects in material and workmanship. Please refer to our Warranty, Application Approvals/Limitations and Return Materials Process as described on [www.axiomatic.com/service.html](http://www.axiomatic.com/service.html).*

Form: TDAX020503-09/26/11