

Dual Valve Controller

4 Universal Inputs

4 +5V References

2-3A Outputs

CAN (SAE J1939)

with Electronic Assistant® 

P/N: AX021800

Features:

- 4 universal signal inputs
- 2 outputs to drive valves up to 3 A
- Fully protected outputs
- 4 +5V Reference Voltages (100 mA)
- 12V, 24V or 48V nominal
- 1 CAN (SAE J1939) port (CANopen® on request)
- Rugged IP67 packaging and connectors
- In fan drive applications, accepts up to 3 sensor inputs with a single switch input for fan reversal
- Can be used without a load as a signal to CAN converter
- **Electronic Assistant®**  together with an Axiomatic USB-CAN converter links the PC to the CAN bus for user configuration.
- Flexible user programming for application-specific control logic via the CAN based Electronic Assistant.



Applications:

The controller is designed to meet the rugged demands of mobile equipment, marine and heavy duty industrial applications. These applications include, but are not limited to:

- **Proportional Fan Drive Control**
- PID Closed Loop Valve Control
- Hydraulic Valve Control
- Signal Conversion

Ordering Part Numbers:

SAE J1939 version Controller: **AX021800**

Accessories:

PL-DTM06-12SA-12SB Mating Plug Kit (no DB-9)

(The KIT is comprised of: DTM06-12S, DTM06-12SB, 2 W12S and 24 contacts.

The Axiomatic stock # is FG-IOCTRL-19.)

AX070502 Configuration KIT includes the following.

USB-CAN Converter P/N: AX070501

1 ft. (0.3 m) USB Cable P/N: CBL-USB-AB-MM-1.5

12 in. (30 cm) CAN Cable with female DB-9 P/N: CAB-AX070501

AX070502IN CD P/N: CD-AX070502, includes: **Electronic Assistant®** software; EA & USB-CAN User Manual

UMAX07050X; USB-CAN drivers & documentation; CAN Assistant (Scope and Visual) software & documentation; and

the SDK Software Development Kit.

NOTE: To order this kit, you need only to specify P/N: AX070502.

In Europe:

Axiomatic Technologies Oy

Höytämöntie 6

33880 LEMPÄÄLÄ - Finland

Tel. +358 3 3595 600

Fax. +358 3 3595 660

www.axiomatic.fi

In North America:

Axiomatic Technologies Corporation

5915 Wallace Street

Mississauga, ON Canada L4Z 1Z8

Tel. 1 905 602 9270

Fax. 1 905 602 9279

www.axiomatic.com

BLOCK DIAGRAM

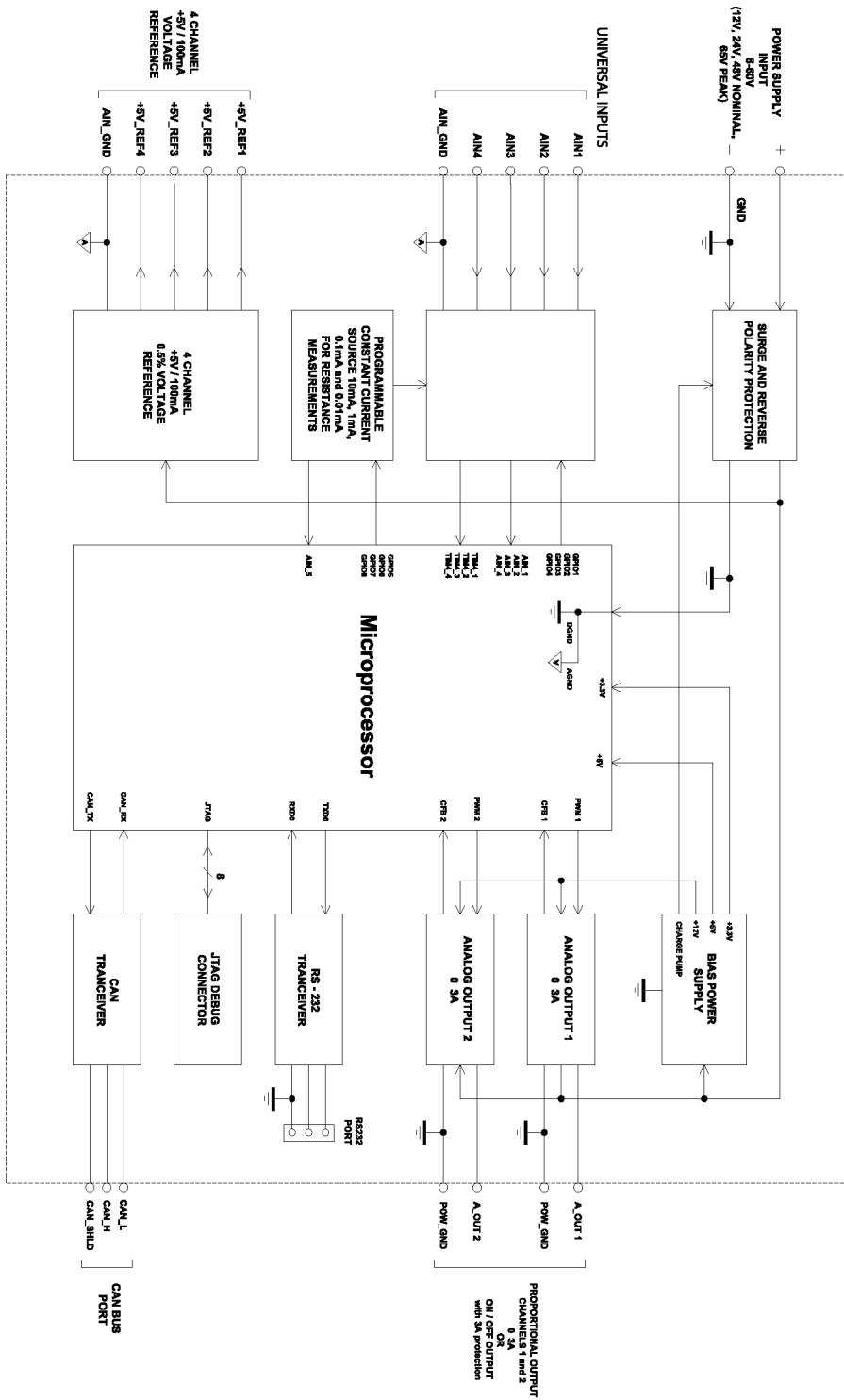

Technical Specifications:

Inputs

Power Supply Input - Nominal	12, 24, 48VDC nominal (8...60 VDC power supply range)
Protection	Reverse polarity protection is provided. Overvoltage protection up to 65V is provided. Overvoltage (undervoltage) shutdown of the output load is provided.
CAN	SAE J1939 Commands CANopen® is available on request.
Universal Signal Inputs	4 universal inputs are provided. Refer to Table 1.0 All input modes are user selectable.

Table 1.0 – Input – User Selectable Options	
Analog Input Functions	Voltage Input, Current Input or Resistive Input
Voltage Input	0-1V (Impedance 1 MOhm) 0-2.5V (Impedance 1 MOhm) 0-5V (Impedance 200 KOhm) 0-10V (Impedance 133 KOhm)
Current Input	0-20 mA (Resistance 124 Ohm) 4-20 mA (Resistance 124 Ohm)
Resistive Input	25Ω to 250 kΩ
Digital Input Functions	Discrete Input, PWM Input, Frequency Input
Digital Input Level	5V CMOS
PWM Input	0 to 100% 10 Hz to 1kHz 100 Hz to 10 kHz
Frequency Input	The controller can interface to sensors with a pulse output. 10 Hz to 1kHz 100 Hz to 10 kHz NOTE: <ul style="list-style-type: none"> • PWM/Frequency input mode can be configured on only two (out of four) inputs: input #1 and #3. • If PWM/Frequency mode is chosen on input #1, then all other inputs cannot be used as analog inputs (for measuring Voltage, Current or Resistance). • If PWM/Frequency mode is chosen on input # 3, all other inputs remain as analog inputs (Voltage, Current or Resistive) or digital inputs.
Digital Input	Active High or Active Low
Input Impedance	1 MOhm High impedance, 10KOhm pull-down, 10KOhm pull-up to +5V
Input Accuracy	≤ 1%
Input Resolution	12-bit

Outputs

CAN	SAE J1939 Messages
Outputs	2 outputs are provided. Up to 3A Half bridge with High Side, Current Sensing, Grounded Load The user can select the following options for output using the EA. <ul style="list-style-type: none"> • Output Disable • Discrete Output • Output Current (PID loop*, with current sensing) • Output Voltage • Output PWM Duty Cycle *Parameters are password protected. Refer to the user manual for details.
Output Accuracy	Output Current mode ≤2% Output Voltage mode ≤3% Output PWM Duty Cycle mode ≤3%
+5V Reference Voltages	4 reference voltages are provided. +5V, 100 mA (current limited to 115 mA)
Protection for Output + Terminal	Fully protected against short circuit to ground and short circuit to power supply rail. Unit will fail safe in the case of a short circuit condition, self-recovering when the short is removed.

General Specifications

Quiescent Current	0.03A @24VDC
Microprocessor	32-bit, 128 KByte or larger program memory
Control Logic	User programmable functionality using Electronic Assistant® Refer to the user manual for details.
Communications	1 CAN port (SAE J1939) CANopen® is available on request.
User Interface	Electronic Assistant® for <i>Windows</i> operating systems It comes with a royalty-free license for use. To use the Electronic Assistant, an USB-CAN converter links the device's CAN port to a <i>Windows</i> -based PC. An Axiomatic USB-CAN Converter AX070501 is available as part of the Axiomatic Configuration KIT. P/N: AX070502 , the Axiomatic Configuration KIT includes the following. USB-CAN Converter P/N: AX070501 1 ft. (0.3 m) USB Cable P/N: CBL-USB-AB-MM-1.5 12 in. (30 cm)CAN Cable with female DB-9 P/N: CAB-AX070501 AX070502IN CD P/N: CD-AX070502, includes: Electronic Assistant® AX070500 software; EA & USB-CAN User Manual UMAX07050X; USB-CAN drivers & documentation; CAN Assistant (Scope and Visual) software & documentation; and the SDK Software Development Kit.
Network Termination	It is necessary to terminate the network with external termination resistors. The resistors are 120 Ohm, 0.25W minimum, metal film or similar type. They should be placed between CAN_H and CAN_L terminals at both ends of the network.

The network part of the controller is compliant with Bosch CAN protocol specification, Rev.2.0, Part B, and the following J1939 standards:

ISO/OSI Network Model Layer	J1939 Standard
Physical	J1939/11 – Physical Layer, 250K bit/s, Twisted Shielded Pair. Rev. SEP 2006. J1939/15 - Reduced Physical Layer, 250K bits/sec, Un-Shielded Twisted Pair (UTP). Issued NOV 2003.
Data Link	J1939/21 – Data Link Layer. Rev. APR 2001. The controller supports Transport Protocol for Commanded Address messages (PGN 65240) and software identification -SOFT messages (PGN 65242). It also supports responses on PGN Requests (PGN 59904).
Network	J1939, Appendix B – Address and Identity Assignments. Rev. 2005-01. J1939/81 – Network Management. Rev. 2003-05. The controller is an Arbitrary Address Capable ECU. It can dynamically change its network address in real time to resolve an address conflict with other ECUs. The controller supports: Address Claimed Messages (PGN 60928), Requests for Address Claimed Messages (PGN 59904) and Commanded Address Messages (PGN 65240).
Transport	N/A in J1939.
Session	N/A in J1939.
Presentation	N/A in J1939.
Application	J1939/71 – Vehicle Application Layer. Rev. NOV 2006 The controller can receive application specific PGNs with input signals and transmit application specific PGNs with up to five output signals. All application specific PGNs are user programmable. J1939/73 – Application Layer – Diagnostics. Rev. SEP 2006 Memory access protocol (MAP) support: DM14, DM15, DM16 messages used by EA to program setpoints.

Electrical Connections

Deutsch DTM series 24 pin receptacle (DTM13-12PA-12PB-R008)
 Mating plug: Deutsch DTM06-12SA and DTM06-12SB
 with 2 wedgelocks (WM12S) and 24 contacts (0462-201-20141).
 20 AWG wire is recommended for use with contacts 0462-201-20141.
Use dielectric grease on the pins when installing the controller.

Key Arrangement B (black)

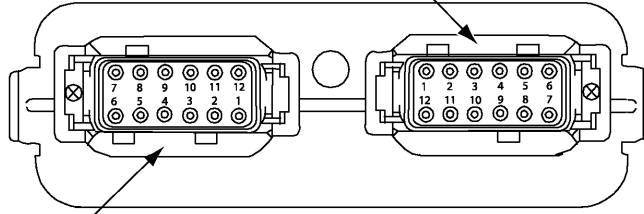

Key Arrangement A (grey)

FRONT VIEW 24 PIN RECEPTACLE

Pin out: AX021800

Grey Connector		Black Connector	
Pin #	Function	Pin #	Function
1	CAN Shield	1	+5V Reference 1
2	Earth (Chassis) GND	2	Universal Input 1
3	Solenoid Valve Output 2 – (internally connected to Power GND)	3	Analog GND 1
4	Solenoid Valve Output 1 – (internally connected to Power GND)	4	Analog GND 2
5	Power GND	5	Universal Input 2
6	Power GND	6	+5V Reference 2
7	Power +	7	+5V Reference 3
8	Power +	8	Universal Input 3
9	Solenoid Valve Output 1 +	9	Analog GND 3
10	Solenoid Valve Output 2 +	10	Analog GND 4
11	CAN Hi	11	Universal Input 4
12	CAN Lo	12	+5V Reference 4

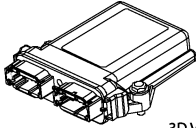
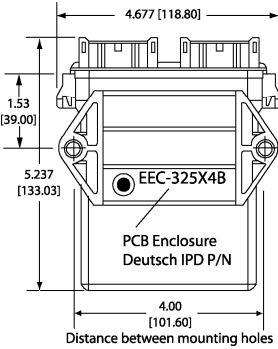
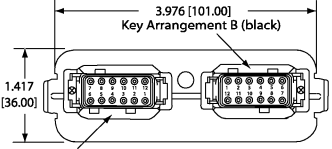
<p>Packaging and Dimensions</p>	<p>High Temperature Nylon housing - Deutsch IPD PCB Enclosure (EEC-325X4B) 4.62 x 5.24 x 1.43 inches 117.42 x 133.09 x 36.36 mm (W x L x H excluding mating plugs)</p> <div style="text-align: center;">  <p>3D VIEW Housing with 24 Pin Receptacle</p> </div> <div style="text-align: right;"> <p>HOUSING DIMENSIONS Housing Material: High Temperature Nylon (Black)</p> </div> <div style="display: flex; justify-content: space-around;"> <div style="text-align: center;">  <p>BOTTOM VIEW</p> </div> <div style="text-align: center;">  <p>FRONT VIEW 24-PIN RECEPTACLE (NOT TO SCALE)</p> </div> </div> <p>Mounting Holes: \varnothing 0.29 [7.40] through 2 pl for 0.25 [6.00] fastener Mounting flange: 16 mm [0.63 in] thick</p> <p>Mating Plug Assemblies for 24-pin receptacle: Deutsch IPD P/N: DTM06-125A and DTM06-125B with wedgelocks WM125 and contacts (Contact factory for contact specification.)</p> <p>Dimensions: inches [mm] excluding mating plug(s)</p>
<p>Operating Conditions</p>	<p>-40 to 85 °C (-40 to 185 °F)</p>
<p>Weight</p>	<p>0.55 lbs. (0.250 kg)</p>
<p>Protection</p>	<p>IP67 rating for the product assembly NOTE : Deutsch IPD connectors are rated at IP67 for submersion (3 ft., 0.9 m) and IP69K for high pressure, high temperature wash down applications.</p>
<p>Installation</p>	<p>Mounting holes sized for ¼ inch or M6 bolts. The bolt length will be determined by the end-user's mounting plate thickness. The mounting flange of the controller is 0.63 inches (16 mm) thick.</p> <p>If the module is mounted without an enclosure, it should be mounted to reduce the likelihood of moisture entry.</p> <p>Install the unit with appropriate space available for servicing and for adequate wire harness access (6 inches or 15 cm) and strain relief (12 inches or 30 cm).</p> <p>The CAN wiring is considered intrinsically safe. The power wires are not considered intrinsically safe and so in hazardous locations, they need to be located in conduit or conduit trays at all times. The module must be mounted in an enclosure in hazardous locations for this purpose.</p> <p>All field wiring should be suitable for the operating temperature range of the module.</p> <p>All chassis grounding should go to a single ground point designated for the machine and all related equipment.</p>

Control Logic

The controller consists of a set of internal functional blocks, which can be individually programmed and arbitrarily connected together to achieve the required system functionality, Fig. 1.

Each functional block is absolutely independent and has its own set of parameters, or setpoints, used to control its functionality. The setpoints are accessible through CAN using Axiomatic Electronic Assistant® (EA) software.

There are two types of the controller functional blocks. One type represents the controller hardware resources, for example: universal inputs or PWM outputs. The other type is purely logical – these functional blocks are included to program the user defined functionality of the controller. The number and functional diversity of these functional blocks are only limited by the system resources of the internal microcontroller. They can be added or modified on the customer's request to accommodate user-specific requirements.

The user can build virtually any type of a custom control by logically connecting inputs and outputs of the functional blocks. This approach gives the user an absolute freedom of customization and an ability to fully utilize the controller hardware resources in a user's application.

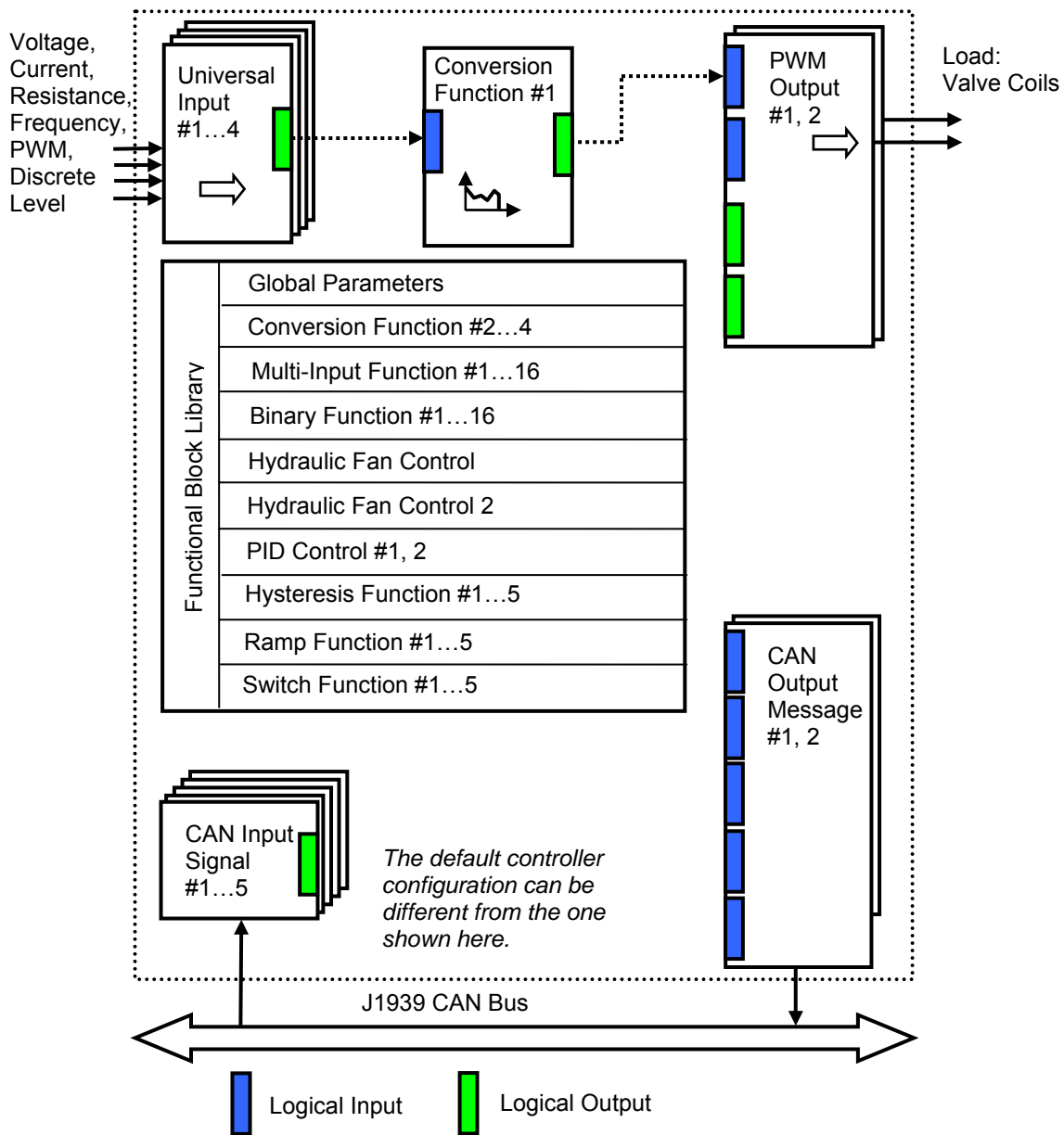

As an example, the Universal Inputs #1 functional block is connected to the Conversion Function #1 and the Conversion Function #1 is connected to the PWM Output #1 functional block, providing a path for the input signal from input to output through the Conversion Function #1 functional block.

Figure 1. The Controller Internal Structure

Note: CANopen® is a registered community trade mark of CAN in Automation e.V.

Specifications are indicative and subject to change. Actual performance will vary depending on the application and operating conditions. Users should satisfy themselves that the product is suitable for use in the intended application. All our products carry a limited warranty against defects in material and workmanship. Please refer to our Warranty, Application Approvals/Limitations and Return Materials Process as described on www.axiomatic.com/service.html.

Form: TDAX021800-06/17/10