

Dual Output Valve Controller

1 Universal Input
+5V reference
CAN (SAE J1939)

with Electronic Assistant® 

P/N: AX022000

Features:

- 1 universal signal input
- 2 proportional or on/off outputs up to 3 A
- User programmable functionality
- 8...60VDC (12V, 24V or 48VDC nominal)
- +5V reference to power a sensor
- 1 CAN (SAE J1939) port
- Aluminum enclosure with integral 12-pin connector
- IP67
- Electronic Assistant®  for user configuration



BLOCK DIAGRAM

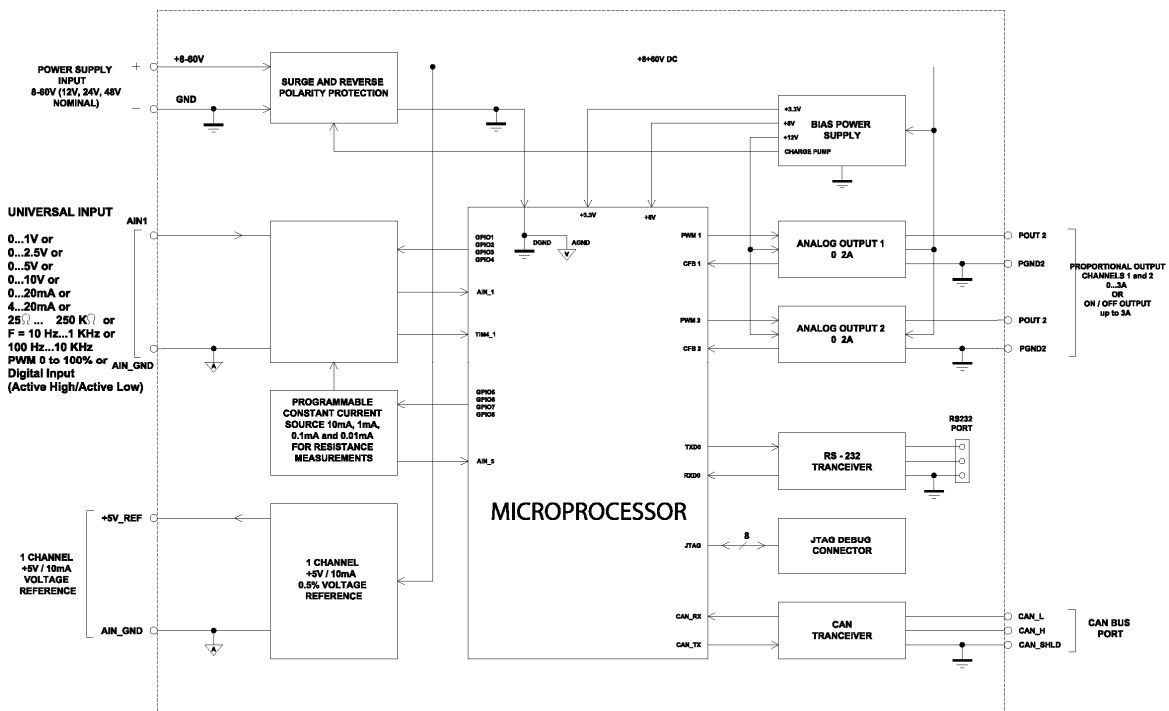

Ordering Part Numbers:

Controller: AX022000
Accessories: AX070105 Mating Plug Kit (DT06-12SA, W12S, 12 0462-201-16141, 3 plugs)
AX070502 Configuration KIT includes the following. USB-CAN Converter P/N: AX070501 1 ft. (0.3 m) USB Cable P/N: CBL-USB-AB-MM-1.5 12 in. (30 cm) CAN Cable with female DB-9 P/N: CAB-AX070501 AX070502IN CD P/N: CD-AX070502, includes: Electronic Assistant® software; EA & USB-CAN User Manual UMAX07050X; USB-CAN drivers & documentation; CAN Assistant (Scope and Visual) software & documentation; and the SDK Software Development Kit. NOTE: To order this kit, you need only to specify P/N: AX070502.

Technical Specifications:

Inputs

Power Supply Input	12V, 24V or 48VDC nominal (8...60 VDC power supply range)
Protection	Reverse polarity protection is provided. Overvoltage protection up to 65V is provided. Overvoltage (undervoltage) shutdown of the output load is provided.
CAN	SAE J1939 Command
Universal Signal Input	Refer to Table 1.0. The input is user selectable.

Table 1.0 – Input – User Selectable Options	
Analog Input Functions	Voltage Input, Current Input or Resistive Input
Voltage Input	0-1V (Impedance 1 MOhm) 0-2.5V (Impedance 1 MOhm) 0-5V (Impedance 200 KOhm) 0-10V (Impedance 133 KOhm for 0-5V, 133 to 20 KOhm for 5-10V))
Current Input	0-20 mA (Impedance 124 Ohm) 4-20 mA (Impedance 124 Ohm)
Resistive Input	25Ω to 250 kΩ
Digital Input Functions	Discrete Input, PWM Input, Frequency Input
Digital Input Level	5V CMOS
PWM Input	0 to 100% 10 Hz to 1kHz 100 Hz to 10 kHz
Frequency Input	10 Hz to 1kHz 100 Hz to 10 kHz
Digital Input	Active High, Active Low
Input Impedance	1 MOhm high impedance, 10KOhm pull down, 10KOhm pull up to +5V
Input Accuracy	≤ 1%
Input Resolution	12-bit

Outputs

CAN	SAE J1939 Messages
Output	2 Proportional or On/Off Outputs (Up to 3A) High Side Switch, Current Sensing, Grounded Load The user can select the following options for output using the EA. <ul style="list-style-type: none"> • Output Disable • Discrete Output • Output Current (PID loop*, with current sensing) • Output Voltage • Output PWM Duty Cycle *Parameters are password protected.
Output Accuracy	Output Current mode ≤ 2% Output Voltage mode ≤ 3% Output PWM Duty Cycle mode ≤ 3%
Voltage Reference	+5V, 10 mA, 0.5% Short circuit protected (current limited to 22-24 mA) Protected from connection to the power supply rail.
Protection for Output + Terminal	Fully protected against short circuit to ground and short circuit to power supply rail. Unit will fail safe in the case of a short circuit condition, self-recovering when the short is removed.

General Specifications

Microprocessor	32-bit, 128 KByte flash program memory
Control Logic	User programmable functionality using Electronic Assistant® Refer to UMAX07050X for details. (Application-specific control logic or factory programmed setpoints are available on request.)
Communications	1 CAN port (SAE J1939), CANopen is available on request.
User Interface	Electronic Assistant® for <i>Windows</i> operating systems It comes with a royalty-free license for use on multiple computers. The Electronic Assistant® requires an USB-CAN converter to link the device's CAN port to a <i>Windows</i> -based PC. An Axiomatic USB-CAN Converter AX070501 is available as part of the Axiomatic Configuration KIT. P/N: AX070502 , the Axiomatic Configuration KIT includes the following. USB-CAN Converter P/N: AX070501 1 ft. (0.3 m) USB Cable P/N: CBL-USB-AB-MM-1.5 12 in. (30 cm) CAN Cable with female DB-9 P/N: CAB-AX070501 AX070502IN CD P/N: CD-AX070502, includes: Electronic Assistant® software; EA & USB-CAN User Manual UMAX07050X; USB-CAN drivers & documentation; CAN Assistant (Scope and Visual) software & documentation; and the SDK Software Development Kit.
Network Termination	It is necessary to terminate the network with external termination resistors. The resistors are 120 Ohm, 0.25W minimum, metal film or similar type. They should be placed between CAN_H and CAN_L terminals at both ends of the network.
Operating Conditions	-40 to 85 °C (-40 to 185 °F)
Packaging	Aluminum enclosure, integral Deutsch IPD connector Encapsulated Refer to the dimensional drawing.
Protection	IP67 rating for the product assembly NOTE : Deutsch IPD connectors are rated at IP67 for submersion (3 ft., 0.9 m) and IP69K for high pressure, high temperature wash down applications.
Weight	0.70 lbs. (0.32 kg)

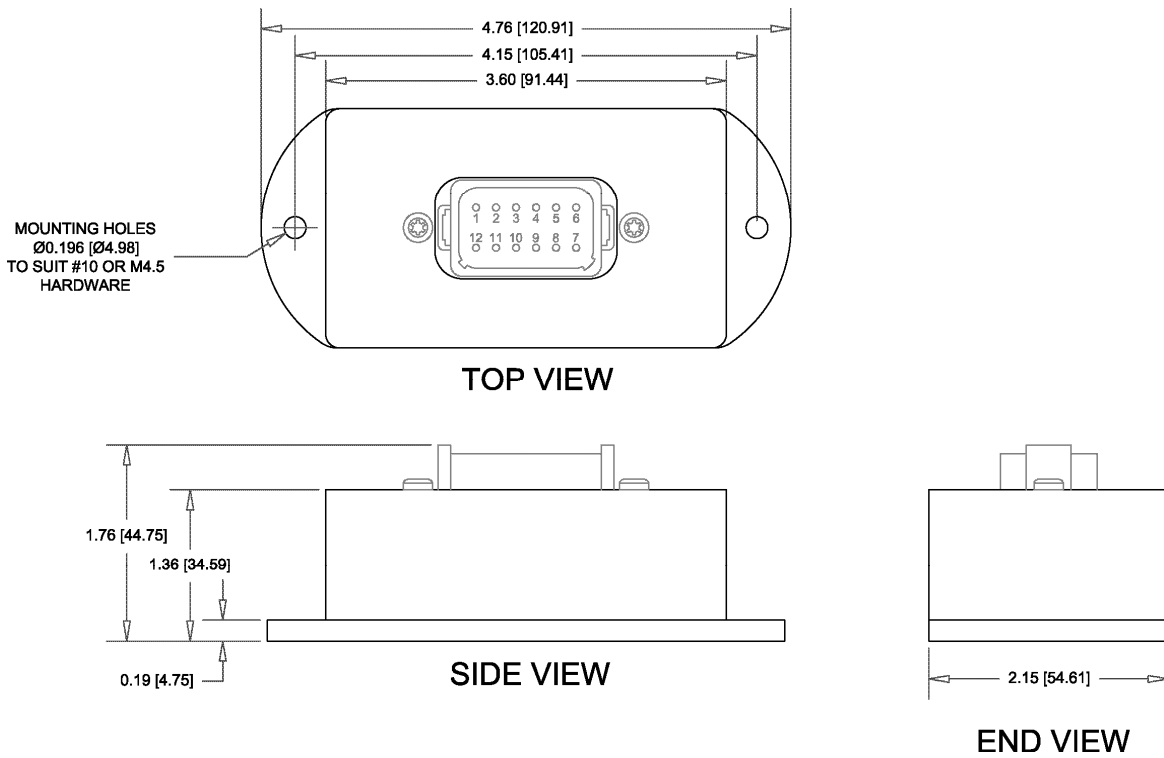

Electrical Connections	<p>12 pin Deutsch IPD connector P/N: DT15-12PA A mating plug kit is available as Axiomatic P/N: AX070105.</p> <table border="1" data-bbox="545 260 972 716"> <thead> <tr> <th colspan="2">CAN and I/O Connector</th> </tr> <tr> <th>Pin #</th> <th>Description</th> </tr> </thead> <tbody> <tr><td>1</td><td>Output 1</td></tr> <tr><td>2</td><td>Output 1 GND</td></tr> <tr><td>3</td><td>Power +</td></tr> <tr><td>4</td><td>CAN Shield</td></tr> <tr><td>5</td><td>CAN_LO</td></tr> <tr><td>6</td><td>CAN_Hi</td></tr> <tr><td>7</td><td>+5V reference</td></tr> <tr><td>8</td><td>Input GND</td></tr> <tr><td>9</td><td>Universal Input 1</td></tr> <tr><td>10</td><td>Power GND</td></tr> <tr><td>11</td><td>Output 2 GND</td></tr> <tr><td>12</td><td>Output 2</td></tr> </tbody> </table>	CAN and I/O Connector		Pin #	Description	1	Output 1	2	Output 1 GND	3	Power +	4	CAN Shield	5	CAN_LO	6	CAN_Hi	7	+5V reference	8	Input GND	9	Universal Input 1	10	Power GND	11	Output 2 GND	12	Output 2
CAN and I/O Connector																													
Pin #	Description																												
1	Output 1																												
2	Output 1 GND																												
3	Power +																												
4	CAN Shield																												
5	CAN_LO																												
6	CAN_Hi																												
7	+5V reference																												
8	Input GND																												
9	Universal Input 1																												
10	Power GND																												
11	Output 2 GND																												
12	Output 2																												
Installation	<p>Mounting holes sized for #10 or M4.5 bolts. The bolt length will be determined by the end-user's mounting plate thickness. The mounting flange of the controller is 0.19 inches (4.75 mm) thick.</p> <p>If the module is mounted without an enclosure, it should be mounted to reduce the likelihood of moisture entry. Install the unit with appropriate space available for servicing and for adequate wire harness access (6 inches or 15 cm) and strain relief (12 inches or 30 cm).</p> <p>The CAN wiring is considered intrinsically safe. The power wires are not considered intrinsically safe and so in hazardous locations, they need to be located in conduit or conduit trays at all times. The module must be mounted in an enclosure in hazardous locations for this purpose.</p> <p>All field wiring should be suitable for the operating temperature range of the module.</p> <p>All chassis grounding should go to a single ground point designated for the machine and all related equipment.</p>																												

The network part of the controller is compliant with Bosch CAN protocol specification, Rev.2.0, Part B, and the following J1939 standards:

ISO/OSI Network Model Layer	J1939 Standard
Physical	J1939/11 – Physical Layer, 250K bit/s, Twisted Shielded Pair. Rev. SEP 2006. J1939/15 - Reduced Physical Layer, 250K bits/sec, Un-Shielded Twisted Pair (UTP). Rev. AUG 2008.
Data Link	J1939/21 – Data Link Layer. Rev. DEC 2006 The controller supports Transport Protocol for Commanded Address messages (PGN 65240) and software identification -SOFT messages (PGN 65242). It also supports responses on PGN Requests (PGN 59904).
Network	J1939, Appendix B – Address and Identity Assignments. Rev. FEB 2010. J1939/81 – Network Management. Rev. 2003-05. The controller is an Arbitrary Address Capable ECU. It can dynamically change its network address in real time to resolve an address conflict with other ECUs. The controller supports: Address Claimed Messages (PGN 60928), Requests for Address Claimed Messages (PGN 59904) and Commanded Address Messages (PGN 65240).
Transport	N/A in J1939.
Session	N/A in J1939.
Presentation	N/A in J1939.
Application	J1939/71 – Vehicle Application Layer. Rev. FEB 2010 The controller can receive application specific PGNs with input signals and transmit application specific PGNs with up to five output signals. All application specific PGNs are user programmable. J1939/73 – Application Layer – Diagnostics. Rev. FEB 2010 Memory access protocol (MAP) support: DM14, DM15, DM16 messages used by EA to program setpoints.

CONTROL ARCHITECTURE

The controller consists of a set of internal functional blocks, which can be individually programmed and arbitrarily connected together to achieve the required system functionality, Fig. 1. The AX022000 is user programmable for functionality using the Electronic Assistant® .

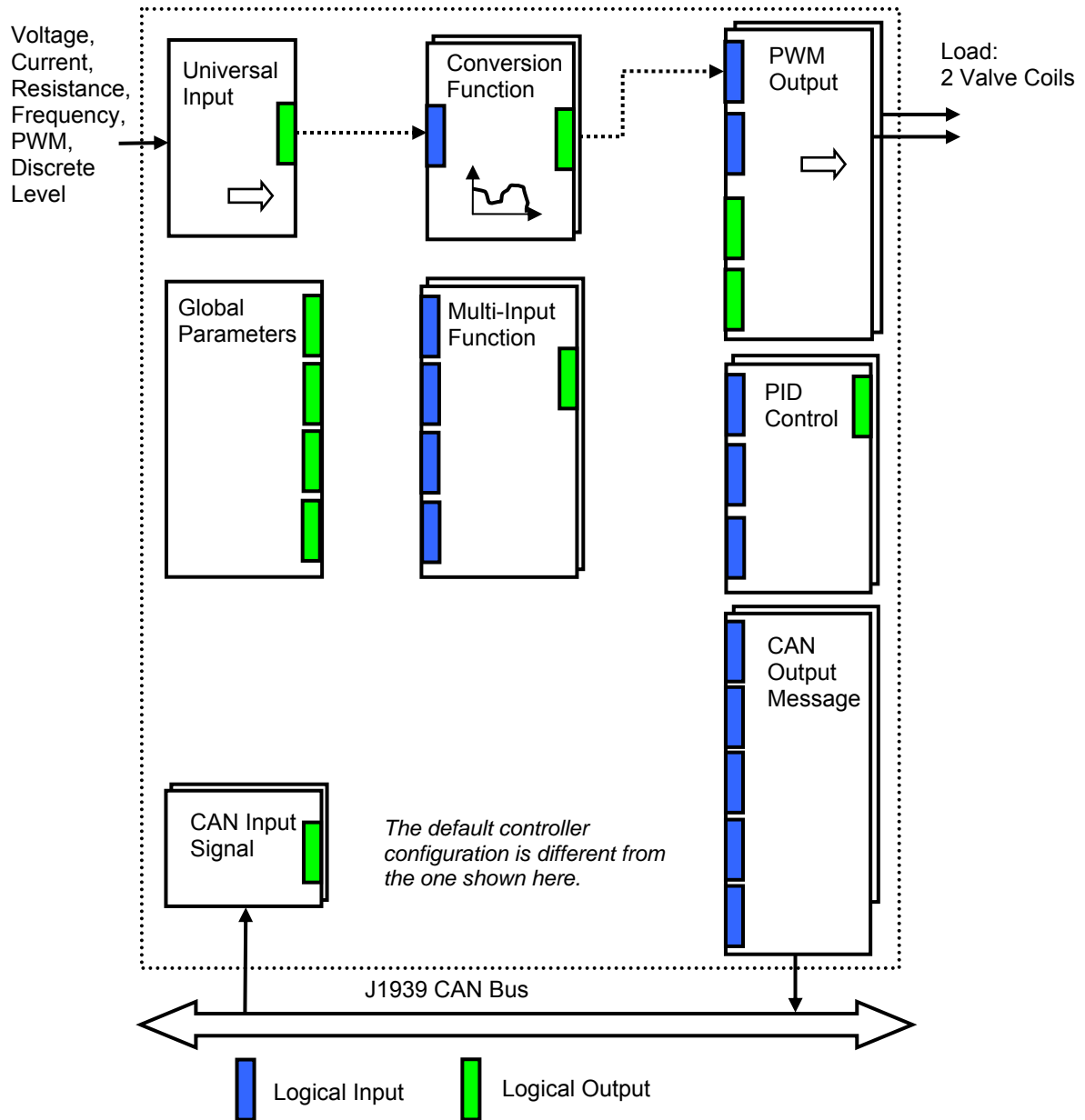

As an example, the Universal Input is connected to a Conversion Function block and the Conversion Function block is connected to a PWM Output block, providing a path for the input signal from input to output through the Conversion Function.

Figure 1. The Controller Internal Structure

Specifications are indicative and subject to change. Actual performance will vary depending on the application and operating conditions. Users should satisfy themselves that the product is suitable for use in the intended application. All our products carry a limited warranty against defects in material and workmanship. Please refer to our Warranty, Application Approvals/Limitations and Return Materials Process as described on www.axiomatic.com/service.html.

Form: TDAX022000-06/21/10