

Preliminary
TECHNICAL DATASHEET #TDAX022610S
Universal Input Fan Drive Controller Platform
with **Simulink®**
P/N: AX022610S

Hardware Functionality:
2 Resistive Inputs, 1 Fan Speed Sensor Input
+5V Reference, 3A PWM Output
High Temperature Operation
CAN (SAE J1939)
IP67

Features:

Controller

- 2 universal signal inputs
- 1 fan speed input (Hall Effect Sensor or digital signal or PWM signal input) with 5V supply
- 1 PWM output up to 3 A (0-50kHz, 0-100%)
- 9...60VDC (12V or 24V or 48VDC nominal)
- 1 CAN SAE J1939 (CANopen® on request)
- High temperature operation for under hood applications
- Aluminum enclosure with 1-12 pin Deutsch IPD DTM15-12PA connector
- IP67
- Axiomatic can provide factory programmed units with the application-specific code.



Software Development Platform

Simulink® is a model-based design tool for embedded systems from Mathworks®. It provides an interactive graphical environment and a customizable block library that lets Axiomatic design and implement application-specific control algorithms via embedded coding tools. Using Simulink®, the OEM machine designer can simulate their control system with the Axiomatic module included. This permits fine tuning of the design parameters and testing of functionality prior to machine prototype installation.

Applications:

- Machine Fan Drive Systems
- Engine Control Valves
- Setpoint Control

Ordering Part Numbers:

Controller with Simulink®: **AX022610S**

Programmed Controllers: **Contact Axiomatic for an ordering p/n.**

Units are factory programmed using the application-specific code requested by the OEM. An application-specific ordering part number will be assigned for the OEM.

Accessories: Mating Plug Kit: **PL-DTM06-12SA** (The KIT is comprised of: DTM06-12S, 1 WM12S and 12 contacts. The Axiomatic stock # is FG-IOCTRL-20.)

Block Diagram

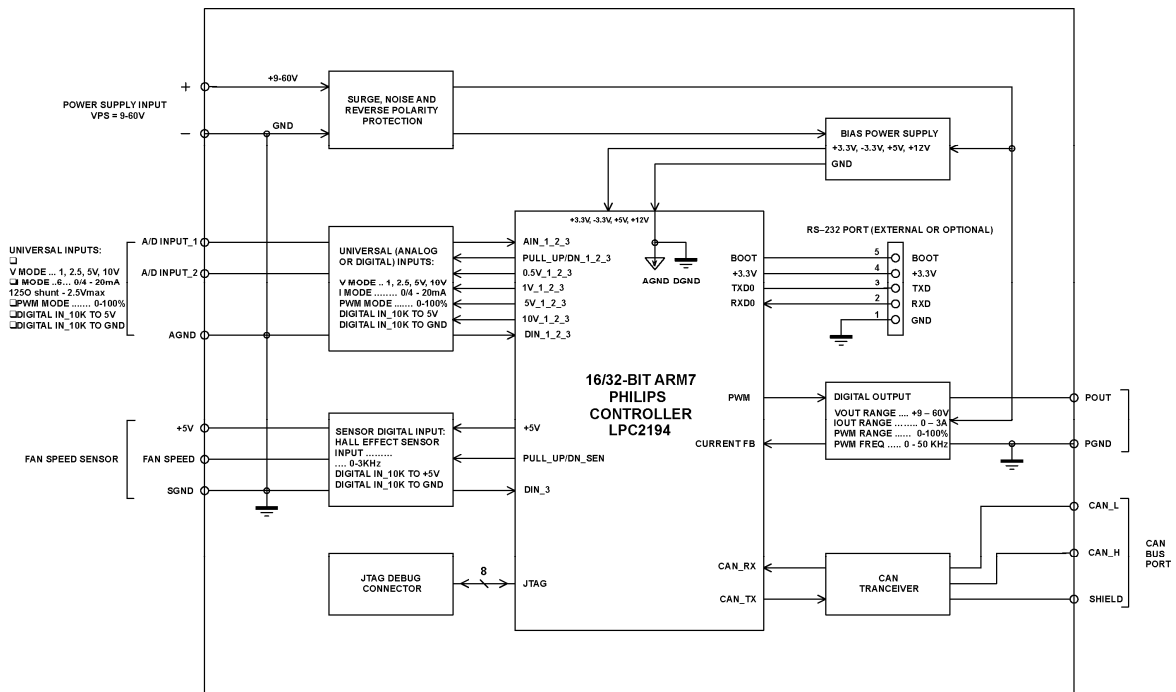

NB. CAN Shield is not available on the connector.

Technical Specifications:

Inputs

Power Supply Input	12V or 24VDC or 48VDC nominal (9...60 VDC power supply range)
Protection	Reverse polarity protection is provided. Overvoltage protection up to 60V is provided. Overvoltage (undervoltage) shutdown of the output load is provided. Short circuit protection is provided.
CAN	SAE J1939 Commands (or CANopen® on request)
Fan Speed Input	1 Hall Effect Sensor input and GND with +5V reference power provided OR Digital Input (5V CMOS) (Active High, Active Low) OR PWM Input (0 to 100%, 0 - 3 kHz)
Signal Input Impedance	10KOhm pull down, 10KOhm pull up to +5V
Voltage Reference	+5V, 50 mA, 0.5% Short circuit protected
Universal Signal Inputs	2 Universal Inputs Refer to Table 1.0. The input is user selectable.

Table 1.0 – Input – User Selectable Options	
Analog Input Functions	Voltage Input, Current Input or Resistive Input
Voltage Input	0-1V (Impedance 1 MOhm) 0-2.5V (Impedance 1 MOhm) 0-5V (Impedance 200 KOhm) 0-10V (Impedance 133 KOhm for 0-5V, 133 to 20 KOhm for 5-10V))
Current Input	0-20 mA (Impedance 124 Ohm) 4-20 mA (Impedance 124 Ohm)
Resistive Input	18Ω to 33.7kΩ
Digital Input Functions	Discrete Input, PWM Input Frequency Input
Digital Input Level	V CMOS
PWM Input	0 to 100% 0 to 10 kHz
Frequency Input	0 to 10 kHz
Digital Input	Active High, Active Low
Input Impedance	1 MOhm high impedance, 10KOhm pull down, 10KOhm pull up to +5V
Input Accuracy	≤1%
Input Resolution	12-bit

Outputs

CAN	SAE J1939 Messages (or CANopen® on request)
Output	Single output, 0-3A 9-60VDC PWM (0-100% D.C., up to 50 kHz) High Side Switch, Current Sensing, Grounded Load
Maximum Operating PWM	50 kHz
Short Circuit Protection	5.5 A
Protection for Output + Terminal	Fully protected against short circuit to ground and short circuit to power supply rail. Unit will fail safe in the case of a short circuit condition, self-recovering when the short is removed.
Output Accuracy	2%

General Specifications

Microprocessor	LPC2194HBD64 32-bit, 256 KByte flash program memory
Control Logic	Axiomatic can provide a programmable configuration tool to interface with the controller. Alternatively, Axiomatic can provide the Controller Platform with a Simulink® interface (P/N: AX022810S). Upon Axiomatic development of the embedded code to meet OEM specifications, units are factory programmed by Axiomatic. An application-specific ordering part number is assigned to the product. <u>Software Development Requirements</u> <i>Axiomatic uses the following tools to model the control and write the embedded software to the OEM's specifications.</i> <ul style="list-style-type: none"> • Software Development Tools: MATLAB®, Simulink®, Real-Time Workshop® (Simulink Coder) and Real-Time Workshop Embedded Coder™ (Embedded Coder) tools from Mathworks® (www.mathworks.com) • ARM compiler • AX022610S, Controller Platform with Simulink® Development using dSPACE and TargetLink® tools can also be requested.
Communications	1 CAN port (SAE J1939), CANopen is available on request.
Network Termination	It is necessary to terminate the network with external termination resistors. The resistors are 120 Ohm, 0.25W minimum, metal film or similar type. They should be placed between CAN_H and CAN_L terminals at both ends of the network.
Operating Conditions	-40 to 125°C (-40 to 257°F)
Packaging	Aluminum enclosure, integral Deutsch IPD connector Encapsulated, Gasket Refer to the dimensional drawing.
Protection	IP67 rating for the product assembly NOTE : Deutsch IPD connectors are rated at IP67 for submersion (3 ft., 0.9 m) and IP69K for high pressure, high temperature wash down applications.
Weight	0.70 lbs. (0.32 kg)

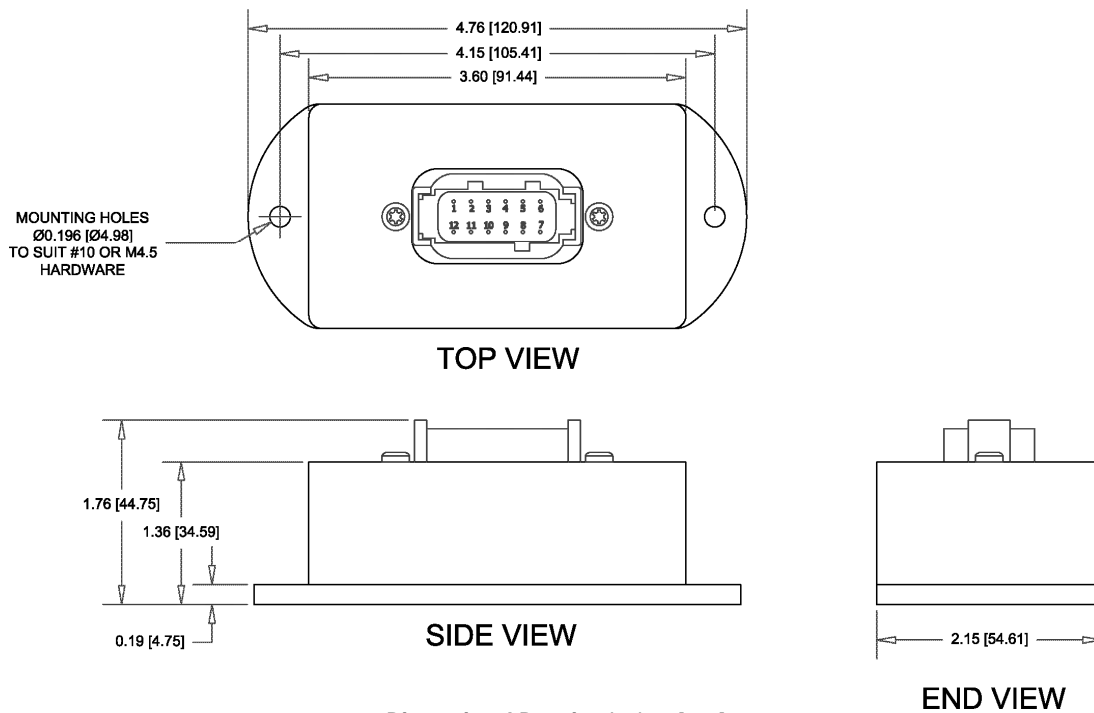

<p>Electrical Connections</p>	<p>12 pin Deutsch IPD connector P/N: DTM15-12PA Mates with: Mating plug KIT: Available from Axiomatic as p/n: PL-DTM06-12SA. It is comprised of the following Deutsch IPD parts: plug (DTM06-12SA); wedgelock (WM12S); and 12 contacts (0462-201-20141) as well as 6 sealing plugs (0413-204-2005).</p> <table border="1" data-bbox="544 1029 1096 1396"> <thead> <tr> <th colspan="2">CAN and I/O Connector</th> </tr> <tr> <th>Pin #</th> <th>Description</th> </tr> </thead> <tbody> <tr><td>1</td><td>Power -</td></tr> <tr><td>2</td><td>Power +</td></tr> <tr><td>3</td><td>CAN H</td></tr> <tr><td>4</td><td>CAN L</td></tr> <tr><td>5</td><td>CAN Shield</td></tr> <tr><td>6</td><td>+5V Reference (Sensor)</td></tr> <tr><td>7</td><td>Sensor Ground</td></tr> <tr><td>8</td><td>Input 1</td></tr> <tr><td>9</td><td>Sensor Input</td></tr> <tr><td>10</td><td>Input 2</td></tr> <tr><td>11</td><td>Output</td></tr> <tr><td>12</td><td>Output GND</td></tr> </tbody> </table>	CAN and I/O Connector		Pin #	Description	1	Power -	2	Power +	3	CAN H	4	CAN L	5	CAN Shield	6	+5V Reference (Sensor)	7	Sensor Ground	8	Input 1	9	Sensor Input	10	Input 2	11	Output	12	Output GND
CAN and I/O Connector																													
Pin #	Description																												
1	Power -																												
2	Power +																												
3	CAN H																												
4	CAN L																												
5	CAN Shield																												
6	+5V Reference (Sensor)																												
7	Sensor Ground																												
8	Input 1																												
9	Sensor Input																												
10	Input 2																												
11	Output																												
12	Output GND																												
<p>Installation</p>	<p>Mounting holes sized for #10 or M4.5 bolts. The bolt length will be determined by the end-user's mounting plate thickness. The mounting flange of the controller is 0.19 inches (4.75 mm) thick.</p> <p>If the module is mounted without an enclosure, it should be mounted to reduce the likelihood of moisture entry. Install the unit with appropriate space available for servicing and for adequate wire harness access (6 inches or 15 cm) and strain relief (12 inches or 30 cm).</p> <p>All field wiring should be suitable for the operating temperature range of the module.</p> <p>All chassis grounding should go to a single ground point designated for the machine and all related equipment.</p>																												

Specifications are indicative and subject to change. Actual performance will vary depending on the application and operating conditions. Users should satisfy themselves that the product is suitable for use in the intended application. All our products carry a limited warranty against defects in material and workmanship. Please refer to our Warranty, Application Approvals/Limitations and Return Materials Process as described on www.axiomatic.com/service.html.

Form: TDAX022610(S)-08/24/11