

48Vdc/24Vdc Step Down Converter

48 Vdc Input
26 Vdc, 330 W Output
P/N: AX081801

Clean power in a rugged package

- Wide input operating voltage 36 to 72 Vdc (48 Vdc nominal)
- Conditioned output of 24Vdc - 26 Vdc (factory set)
- High current output capability (13 A nominal, 18A peak)
- 330 Watts output power
- Switch mode operation delivers very high efficiency >95%
- Design manages heat dissipation avoiding forced cooling
- Reverse polarity, input under/over voltage protections
- Inrush current limit
- Overtemperature protection
- Short-circuit protection
- Rugged and highly reliable
- Compact size for ease of mounting in confined spaces
- Suitable for moist, high shock and vibration environments
- Operational from -40 to 85°C
- IP67 protection
- EMI/EMC compliant
- UL 583 recognition
- Current sharing, redundancy for parallel applications



Applications: Designed to interface between 48V batteries and 26V/24V electrical systems such as solenoids, relays and other electrical systems found on mobile equipment, lift trucks and buses.

BLOCK DIAGRAM

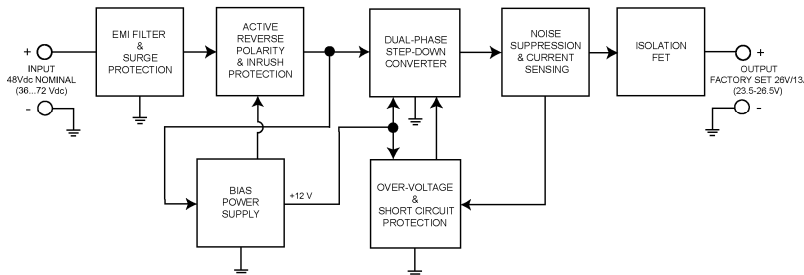

Ordering Part Numbers:

Converter with Wire Harness KIT:

AX081801K (KIT AX081801 Converter, WH-DTP06-4S-S-2M Wire Harness)

Items can also be ordered individually.

Converter: **AX0801801**

Mating Wire Harness, 2 m: **WH-DTP06-4S-S-2M**

Description: The DC-DC Converter provides regulated 26 Vdc/24Vdc power suitable for solenoids, relays and other electrical systems. For operation under the most harsh and demanding conditions, the IP67 rated unit protects against moisture, shock and vibration. Power from a battery or other source of 48 Vdc is converted to a 24-26 Vdc output. The unit has a high current output capability of 13 Amps. The device manages heat dissipation and requires no forced cooling systems. Short-circuit and reverse polarity protections are provided. The compact unit is designed with extremely rugged surge and transient suppression in addition to sustained over/under voltage protection. With a nameplate rating of 330 Watts of output power, the DC-DC Converter provides proprietary dual-phase topology for a high efficiency of >95%.

Technical Specifications:

All specifications are typical at nominal input voltage and 25 degrees C unless otherwise specified.

Input Specifications		Output Specifications	
Power Source	48 Vdc nominal	Nameplate Rating (Output Power)	330 Watts nominal
Operating Voltage Range	36 to 72 Vdc	Output Current (DC)	13 A continuous (18A peak)
Maximum Input Current	10 A _{bc} @ 36 VDC, 13 A I-output	Output Voltage	23.5-26.5 Vdc Maximum Factory set at 26 Vdc (nominal) ± 0.5%
Inrush Current Protection	Provided	Output Voltage Ripple	$V_{O(RIPPLE)} \leq 100$ mVpp
Input Reverse & Under/Over-voltage Protection	Provided	Rise Time (with full load)	30-70 msec. at maximum load
Output Over-voltage Protection	Provided	Turn-on Overshoot	<1% of output voltage
Isolation	Not provided	Stability	Stable at all load conditions
		Transient Response	5% of Output Voltage (25% - 75% Load, $V_{in} = 48V$)
		Short-Circuit Protection	Provided, Auto-recover
		Overload Protection	Provided 16.5 ±1.5A
General Specifications			
Efficiency	>95%		
Quiescent Current	15 mA @ 48Vdc Typical		
Operating Temperature	-40 to 85°C (-40 to 185°F)		
Storage Temperature	-40 to 85°C (-40 to 185°F)		
Humidity	0-99% relative humidity (non-condensing)		
UL recognition	UL583 for use on Type E, ES, or EE Battery Powered Industrial Trucks		
Vibration	MIL-STD-202G, Test 204D and 214A (Sine and Random), Test 213BA – 6 ms (Shock) 15 g peak (Sine) 7.68 Grms peak (Random) 50g (Shock)		
Protection rating	IP67		
Electrical Connection	4 pin Deutsch connector P/N: DTP13-4P <u>Pin Out</u> 1. Power + 2. Output + 3. Output – 4. Power – A mating plug assembly with 12 AWG unterminated lead wires is available. Ordering P/N: WH-DTP06-4S-S-2M (The mating plug assembly is comprised of Deutsch P/N: DTP06-4S, WP4S and four contact sockets 0462-203-12141 with 2 meters (6.5 ft.) of 12 AWG lead wire, unterminated.) <u>Wire Harness Pin out:</u> Input + Red Output + Red/White Output – Black/White Input - Black		

Weight	3.00 lbs. (1.37 kg)
Dimensions	5.35 x 7.00 x 2.39 inches (W x L x H including connector) 136.0 x 177.7 x 60.6 mm

Dimensional Drawing

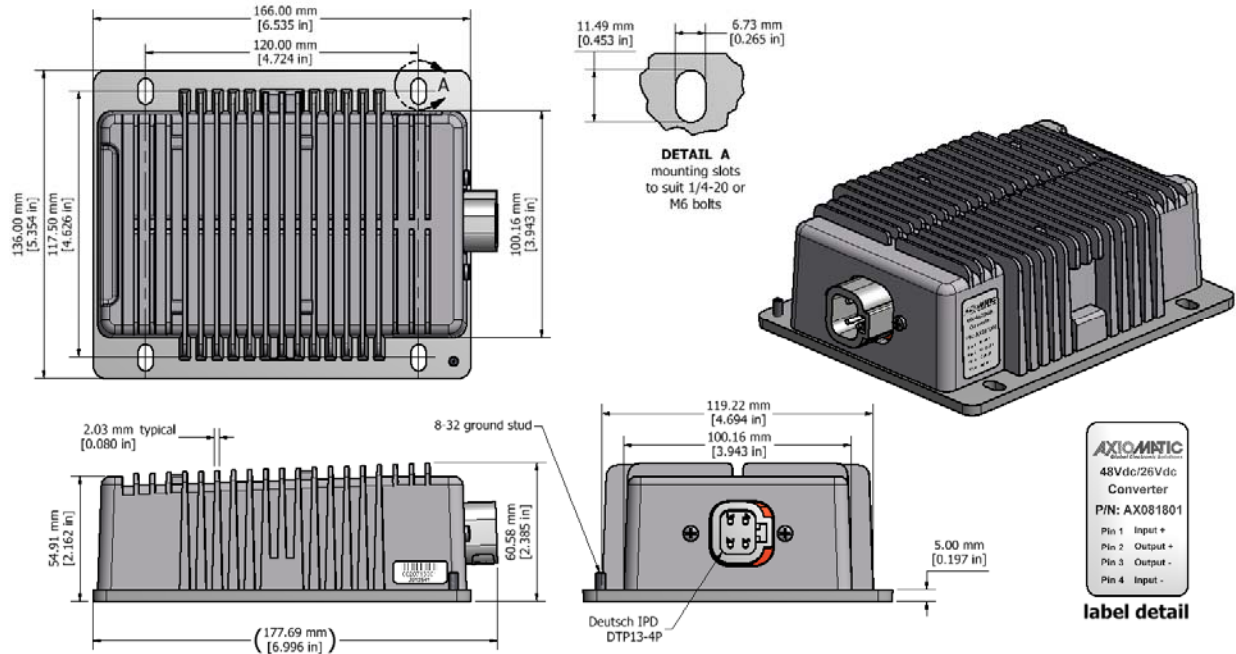

Installation	
Set up	
<ol style="list-style-type: none"> 1. A 15A fuse is recommended in the primary circuit to provide protection for the primary wiring. 2. Use four ¼-20 1 inch screws to mount the converter. 3. Snap the mating plug connector with wiring harness into the receptacle mounted on the converter. 4. Once the load is ready to receive power, turn on the power source to the converter. 	
Grounding	Protective Earth (PE) must be connected to the chassis to reduce the risk of electric shock. All chassis grounding should go to a single ground point designated for the machine and all related equipment.
Mounting	<p>Mounting ledges include holes sized for ¼ inch or M6 bolts. The bolt length will be determined by the end-user's mounting plate thickness. Typically, ¾ inch (20 mm) is adequate.</p> <p>If the module is mounted without an enclosure, it should be mounted vertically with connectors facing left and right to reduce likelihood of moisture entry.</p> <p>All field wiring should be suitable for the operating temperature range of the module.</p> <p>Install the unit with appropriate space available for servicing and for adequate wire harness access (6 inches or 15 cm) and strain relief (12 inches or 30 cm).</p>
Paralleling	The converters can be installed in a parallel configuration for current sharing or redundancy.

Specifications are subject to update without notice.
Form: TDAX081801-04/11/17