

## TECHNICAL DATASHEET #TDAX100270 UNIVERSAL MOTOR CONTROLLER, 100W

**Up to 4 Universal Signal Inputs, SENT Inputs  
3 Encoder Inputs or PWM Outputs  
2 +5V, 200 mA Reference Voltages  
1 BLDC or 2 Bidirectional Brushed DC Motor Control Outputs up to 6A  
Sensorless or Hall Effect Sensor Feedback  
2 CAN (SAE J1939)  
with Electronic Assistant®**

**P/N: AX100270**

**Description:** The universal motor controller, 100W, drives a brushed DC Motor up to 6A or a 3-phase BLDC motor up to 6A. It features two SAE J1939 ports. Interfacing with 12V or 24Vdc power, the controller accepts 4 universal inputs (voltage, current, Frequency, PWM, SENT or digital input types). Hall sensor feedback input is accepted. In addition, the controller interfaces with 3 standard A and B phase encoder inputs or can provide 3 PWM signal outputs. Settings are user configurable to suit many applications. Configuration is via a *Windows*-based Electronic Assistant® configuration tool and an USB-CAN converter. The controller is packaged in a TE Deutsch enclosure and 24-pin connector.



### Applications:

Typical applications can include: test stands; and industrial automation.

### Features:

- Drives up to 2 bidirectional brushed DC Motors up to 6A (2 bidirectional full bridge outputs)
- Or can drive a BLDC Motor, 3 Phase, up to 6A (a half-bridge output with sensorless or Hall Effect sensor operation)
- Four (4) Universal Signal Inputs are user selectable:
  - Analog (0-5V, 0-10V, 4-20 mA or 0-20 mA);
  - Digital;
  - SENT;
  - PWM;
  - or Frequency signal types.
- Provides 2 +5V, 200 mA reference voltages to power devices
- Three (3) encoder inputs or one Quadrature encoder input and one PWM input are accepted. Alternatively, 3 PWM outputs can be provided.
- Robust 6...36Vdc power supply interface with reverse polarity protection
- Reverse polarity, under and overvoltage protection provided
- Operational from -40 to 85°C (-40 to 185°F)
- Two (2) CAN (SAE J1939) port permits networking
- **Electronic Assistant®** runs on a *Windows* operating system for user configuration. An Axiomatic USB-CAN converter links the PC to the CAN bus.
- TE Deutsch enclosure and connectors

### Ordering Part Numbers:

SAE J1939 Controller: AX100270

Accessories:

**PL-DTM06-12SA-12SB** Mating Plug Kit (1 DTM06-12S, DTM06-12SB, 2 W12S, 24 contacts)

Electronic Assistant® Configuration KIT: **AX070502**

In Europe:  
Axiomatic Technologies Oy  
Höytämöntie 6  
33880 LEMPÄÄLÄ - Finland  
Tel. +358 103 375 750  
Fax. +358 3 3595 660  
www.axiomatic.fi

In North America:  
Axiomatic Technologies Corporation  
5915 Wallace Street  
Mississauga, ON Canada L4Z 1Z8  
Tel. 1 905 602 9270  
Fax. 1 905 602 9279  
www.axiomatic.com

## Block Diagram:

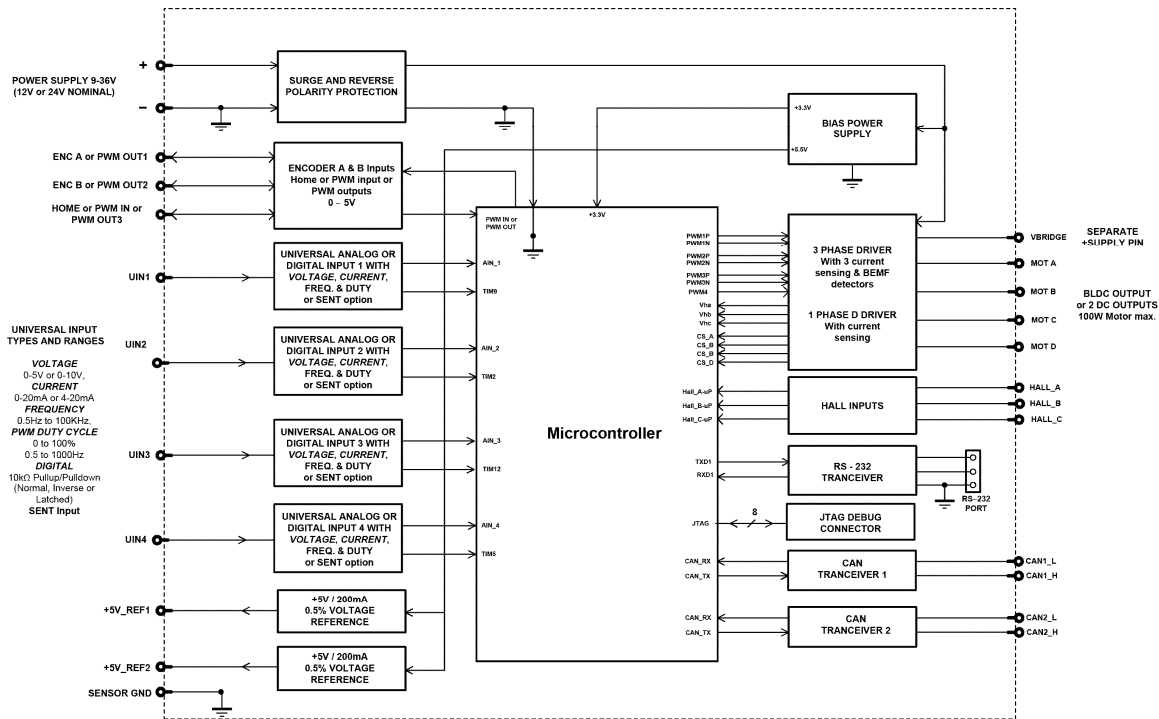

Figure 1.0 Block Diagram

### Technical Specifications:

Specifications are indicative and subject to change. Actual performance will vary depending on the application and operating conditions. Users should satisfy themselves that the product is suitable for use in the intended application. All our products carry a limited warranty against defects in material and workmanship. Please refer to our Warranty, Application Approvals/Limitations and Return Materials Process as described on [www.axiomatic.com/service.html](http://www.axiomatic.com/service.html).

### Input Specifications (Refer to the block diagram.)

Power Supply Input	12 or 24Vdc nominal (6...36 Vdc power supply range) NB. The maximum total current draw permitted on the power supply input pins is 7.5 Amps @ 24Vdc, at one time.
Reverse Polarity Protection	Provided up to -80Vdc
Surge and Transient Protection	Provided
Under-voltage Protection	Provided (hardware shutdown at 6V)
Overvoltage Protection	Provided (hardware shutdown at 41V)
Universal Signal Inputs	Up to 4 inputs are selectable by the user from the following. <ul style="list-style-type: none"> <li>Analog Voltage (0-5V, 0-10V), Current (0-20 mA, 4-20mA, 249Ω current sense resistor)</li> <li>Frequency or PWM Inputs</li> <li>Digital</li> <li>Or SENT (option).</li> </ul> 12-bit Analog to Digital resolution Amplitude up to +Vsupply Protected against shorts to GND. See Tables 1 and 2. NB.SAE J2716 SENT (Single Edge Nibble Transmission) protocol is a point-to-point scheme for transmitting signal values from a sensor to a controller.

Encoder Inputs	<p>Three (3) Standard A and B and Home phase encoder inputs Alternatively, one PWM input and one Quadrature Encoder input can be selected. Frequency Range: 0-250 kHz Amplitude: 0-5Vdc</p> <p>This feature is user configurable as PWM Outputs (see Output section).</p>																																												
Hall Sensor	<p>Standard open collector/drain HALL EFFECT Sensor Input type (3) 1K Pull-up to +5V per input is provided.</p>																																												
Minimum and Maximum Ratings	<table border="1"> <thead> <tr> <th colspan="4"><b>Table 1.0. Absolute Maximum and Minimum Ratings</b></th> </tr> <tr> <th><b>Characteristic</b></th> <th><b>Min</b></th> <th><b>Max</b></th> <th><b>Units</b></th> </tr> </thead> <tbody> <tr> <td>Power Supply</td> <td>6</td> <td>36</td> <td>V dc</td> </tr> <tr> <td>Voltage Input</td> <td>0</td> <td>36</td> <td>V dc</td> </tr> <tr> <td>Current Input</td> <td>0</td> <td>21</td> <td>mA</td> </tr> <tr> <td>Current Input – Voltage Level</td> <td>0</td> <td>12</td> <td>Vdc</td> </tr> <tr> <td>Digital Type Input – Voltage Level</td> <td>0</td> <td>36</td> <td>Vdc</td> </tr> <tr> <td>PWM Duty Cycle</td> <td>0</td> <td>100</td> <td>%</td> </tr> <tr> <td>PWM Frequency</td> <td>50</td> <td>1 000</td> <td>Hz</td> </tr> <tr> <td>PWM Voltage pk - pk</td> <td>0</td> <td>36</td> <td>V dc</td> </tr> <tr> <td>Frequency</td> <td>50</td> <td>10 000</td> <td>Hz</td> </tr> </tbody> </table>	<b>Table 1.0. Absolute Maximum and Minimum Ratings</b>				<b>Characteristic</b>	<b>Min</b>	<b>Max</b>	<b>Units</b>	Power Supply	6	36	V dc	Voltage Input	0	36	V dc	Current Input	0	21	mA	Current Input – Voltage Level	0	12	Vdc	Digital Type Input – Voltage Level	0	36	Vdc	PWM Duty Cycle	0	100	%	PWM Frequency	50	1 000	Hz	PWM Voltage pk - pk	0	36	V dc	Frequency	50	10 000	Hz
<b>Table 1.0. Absolute Maximum and Minimum Ratings</b>																																													
<b>Characteristic</b>	<b>Min</b>	<b>Max</b>	<b>Units</b>																																										
Power Supply	6	36	V dc																																										
Voltage Input	0	36	V dc																																										
Current Input	0	21	mA																																										
Current Input – Voltage Level	0	12	Vdc																																										
Digital Type Input – Voltage Level	0	36	Vdc																																										
PWM Duty Cycle	0	100	%																																										
PWM Frequency	50	1 000	Hz																																										
PWM Voltage pk - pk	0	36	V dc																																										
Frequency	50	10 000	Hz																																										
Input Accuracy and Resolution	<table border="1"> <thead> <tr> <th colspan="3"><b>Table 2.0. Input Accuracy</b></th> </tr> <tr> <th><b>Input Type</b></th> <th><b>Accuracy</b></th> <th><b>Resolution</b></th> </tr> </thead> <tbody> <tr> <td>Voltage</td> <td>+/- 1%</td> <td>1 [mV]</td> </tr> <tr> <td>Current</td> <td>+/- 1%</td> <td>1 [uA]</td> </tr> <tr> <td>PWM</td> <td>+/- 1%</td> <td>0.1 [%]</td> </tr> <tr> <td>Frequency</td> <td>+/- 1%</td> <td>0.01 [Hz]</td> </tr> </tbody> </table>	<b>Table 2.0. Input Accuracy</b>			<b>Input Type</b>	<b>Accuracy</b>	<b>Resolution</b>	Voltage	+/- 1%	1 [mV]	Current	+/- 1%	1 [uA]	PWM	+/- 1%	0.1 [%]	Frequency	+/- 1%	0.01 [Hz]																										
<b>Table 2.0. Input Accuracy</b>																																													
<b>Input Type</b>	<b>Accuracy</b>	<b>Resolution</b>																																											
Voltage	+/- 1%	1 [mV]																																											
Current	+/- 1%	1 [uA]																																											
PWM	+/- 1%	0.1 [%]																																											
Frequency	+/- 1%	0.01 [Hz]																																											
Analog Ground	One sensor ground connection is provided.																																												
Reference Voltages	2 +5V, 200 mA maximum Regulation at +/-0.5% accuracy is provided.																																												

## Output Specifications

Outputs	<p>Two outputs for a bidirectional Brushed DC Motor, up to 6A</p> <ul style="list-style-type: none"> <li>Two bidirectional full bridge outputs</li> </ul> <p>Or One output for a BLDC Motor, up to 6A</p> <ul style="list-style-type: none"> <li>One 3-phase half-bridge output, current sensing per each phase</li> <li>Sensorless or HALL Effect Sensor operation</li> </ul> <p>6A nominal current output (100W)</p> <p>NB. The maximum total current draw permitted on the power supply input pins is 7.5 Amps @ 24Vdc, at one time.</p>
V Bridge Connection	Separate +Vsupply connection for motor outputs
PWM Outputs	Up to 3 independent PWM outputs (available if 3 encoder inputs option is not selected) PWM Frequency: 0-250 kHz Duty Cycle: 0 to 100%
Output Accuracy	PWM outputs +/-0.1%
Protection	Overcurrent protection is provided on all outputs. It is programmable.

### General Specifications

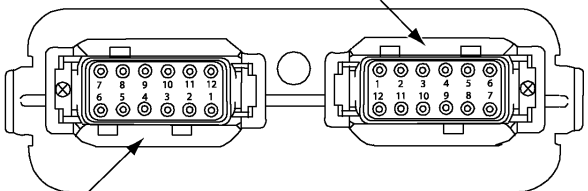
Operating Conditions	-40 to 85°C (-40 to 185°F)
Weight	0.60 lb. (0.272 kg)
Protection	IP65; Unit is conformal coated within the housing.
Microprocessor	STM32F407VGT7
Quiescent Current Draw	45 mA @ 24Vdc Typical; 73 mA @ 12Vdc Typical
CAN Interface	2 CAN ports (SAE J1939) 250 kbps baud rate (default) To change the baud rate, reflash with the appropriate firmware for that baud rate. Contact Axiomatic for instructions.
Network Termination	It is necessary to terminate the network with external termination resistors. The resistors are 120 Ohm, 0.25W minimum, metal film or similar type. They should be placed between CAN_H and CAN_L terminals at both ends of the network.
Control Logic	Standard embedded software is provided and is configurable using the Electronic Assistant® (EA).
Simulink®	The firmware as developed using Simulink®.
User Interface	User configuration and diagnostics are provided with the Axiomatic Electronic Assistant®, p/n AX070502.
Software Flashing	Use the Electronic Assistant, AX070502.
Electrical Connections	<p>Refer to Table 3.0. Deutsch DTM series 24 pin receptacle (DTM13-12PA-12PB-R008) Mating plugs kits are available on request and include Deutsch DTM06-12SA and DTM06-12SB with 2 wedgelocks (WM12S) and 24 contacts (0462-201-20141). 20 AWG wire is recommended for use with contacts 0462-201-20141.</p> <p style="text-align: center;"><b>Key Arrangement B (black)</b></p>  <p style="text-align: center;"><b>Key Arrangement A (grey)</b></p> <p style="text-align: center;"><b>FRONT VIEW 24 PIN RECEPTACLE</b></p>
Packaging and Dimensions	High Temperature Nylon housing, Deutsch IPD PCB Enclosure (EEC-325X4B) 4.62 x 5.24 x 1.43 inches 117.42 x 133.09 x 36.36 mm (W x L x H excluding mating plug) Refer to Figure 2.0.

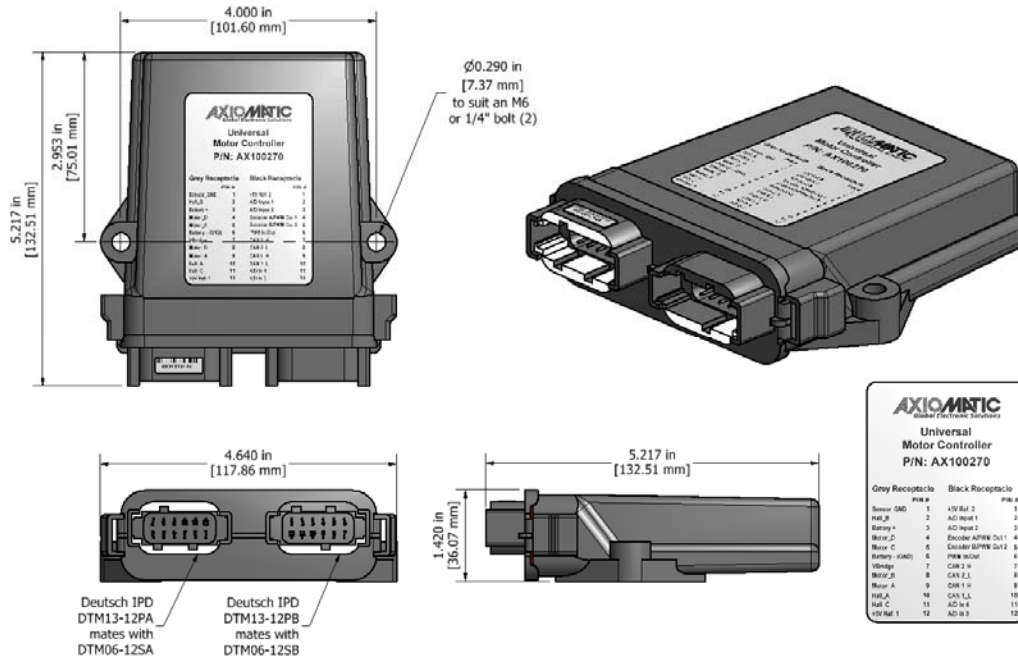

Figure 2.0 - Dimensional Drawing

Table 3.0 – Pin out: AX100270

Grey Connector PIN #	Function	Black Connector PIN #	Function
1	Sensor GND	1	+5V Reference 2
2	Hall B	2	A/D Input 1
3	Battery +	3	A/D Input 2
4	Motor D	4	Encoder A/PWM Out 1
5	Motor C	5	Encoder B/PWM Out 2
6	Battery - (GND)	6	PWM In/Out
7	V Bridge	7	CAN 2_H
8	Motor B	8	CAN 2_L
9	Motor A	9	CAN 1_H
10	Hall A	10	CAN 1_L
11	Hall C	11	A/D Input 4
12	+5V Reference 1	12	A/D Input 3

CANopen® is a registered community trade mark of CAN in Automation e.V.  
 Electronic Assistant® is a registered U.S. trade mark of Axiomatic Technologies Corporation.  
 Simulink® is a registered trademark of The Mathworks, Inc.

Form: TDAX100270-07/23/18