

**Technical Datasheet #TDAXTC20CO**  
**Thermocouple Scanner**  
**20 Thermocouple Channels**  
**CANopen®**  
**P/N: AXTC20CO**

**Description:** The Thermocouple Scanner monitors up to 20 thermocouple channels and the temperature information is provided to the engine control system over CANopen®. The channels are independently configurable as Type J, K, B, E, N, R, S or T thermocouples. The scanner can flag low temperature warnings, high temperature warnings, or high temperature shutdowns to the engine control system. It will also detect and indicate open circuits on the sensor wires. The average temperature of all the active channels, or all channels from a block of 10, can be broadcasted to the CAN network. Active channels are scanned sequentially (1 to 20) with approximately 100 ms (2.4 sec) between readings. Temperature is measured in °C, with a 0.001°C resolution. The scanner will send temperatures with +/- 1°C accuracy. The operator has the option of disabling the automatic cold-junction compensation and if this setup is used, the scanner's field value temperatures will have a +/- 0.2°C accuracy. Using commercially available CANopen® service tools, the operator can configure the controller to suit a wide variety of applications using SDO object access, per CiA DS-301. An EDS file is provided. Settings are saved to non-volatile memory upon command. All channels are fully isolated from the CAN line, and from the power supply. The power supply was designed for nominal inputs of 12V or 24Vdc and is operational from 9-32Vdc. A SAE J1939 model is available.



The Thermocouple Scanner features rugged packaging and watertight Deutsch IPD connectors for an IP67 rating. The module is UL recognized for UL508 (FTPM2) – Controls for Stationary Engine Driven Assemblies. The control is EMC compliant and meets the environmental and vibration requirements of generator set applications. It carries marine type approvals and CSA or ATEX approvals for hazardous locations.

**Applications:** Control systems for industrial and marine power generator sets (stationary or portable)

**Ordering Part Numbers:**

20 Channel Thermocouple Module, CANopen® P/N: **AXTC20CO**  
 EDS File, User Manual can be downloaded from our website. Go to [www.axiomatic.com](http://www.axiomatic.com) to the log-in section and enter the password available from [sales@axiomatic.com](mailto:sales@axiomatic.com).

**Mating Plug Kit P/N: AX070200**

This kit includes the following items. These items are also available from a local Deutsch IPD distributor.  
*NB. The sealing plugs are only needed in cases where less than 20 thermocouple channels are installed. A crimping tool from Deutsch IPD is required to connect wiring to the sockets, P/N: HDT 48-00 or equivalent (not supplied).*

Deutsch IPD P/N:	Description:
0462-201-16141	48 16AWG SOCKETS SOLID 16-20AWG WIRE 6mm
114017	24 SEALING PLUGS SIZE 12-16 CAVITIES 12-18 AWG
DRC16-40S	40-PIN PLUG, No Key
DT06-08SA	DT SERIES PLUG 8 CONTACT
W8S	WEDGELOCK FOR DT 8 PIN PLUG

# Block Diagram

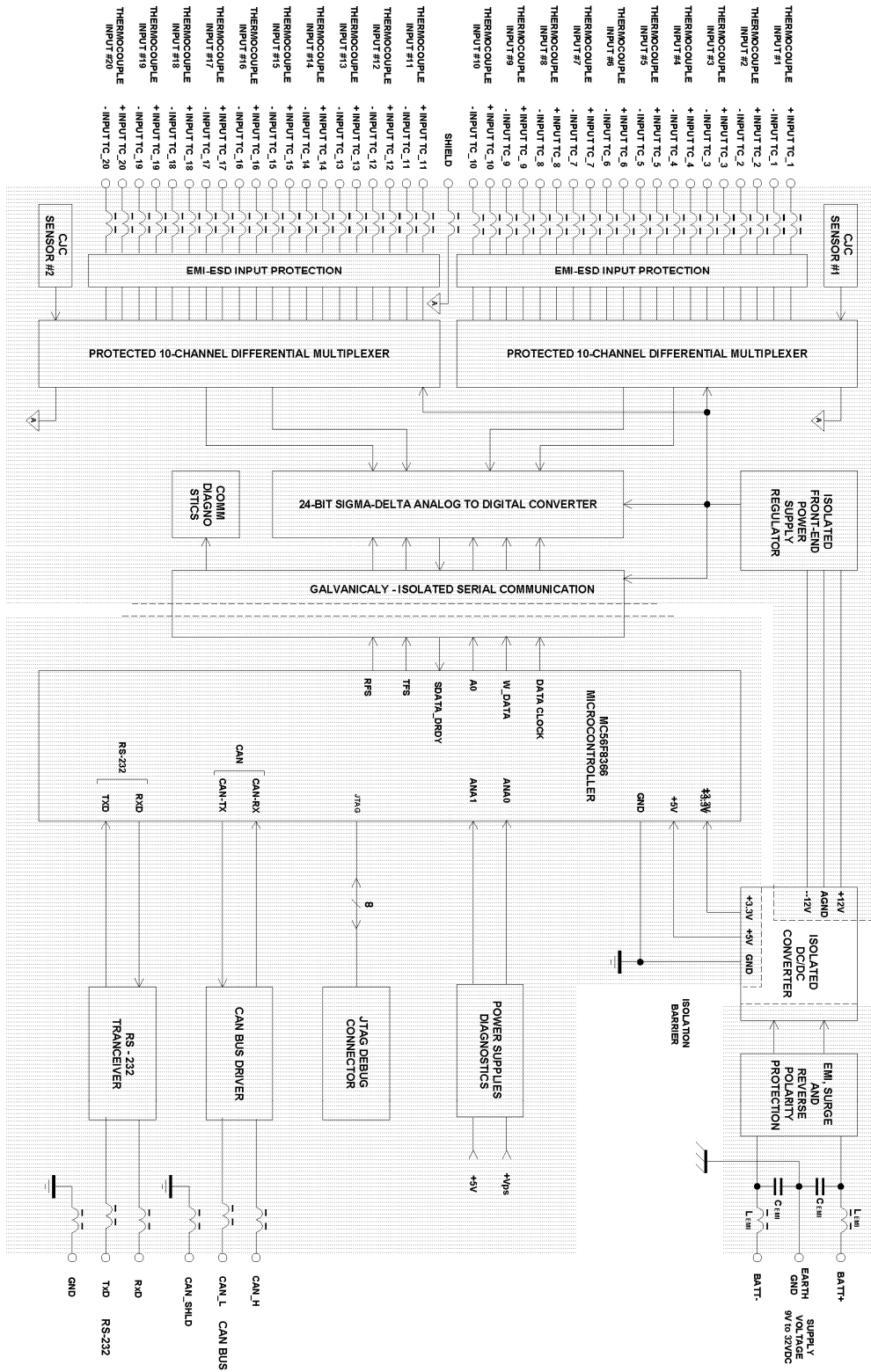

## Technical Specifications

### Inputs

Power Supply Input	12V or 24VDC nominal (9...32 VDC power supply range)
Supply Current	200 mA at 12 V Typical 100 mA at 24 V Typical
Protection	Reverse polarity protection is provided. Power supply input section protects against transient surges and short circuits and is isolated from thermocouple inputs
Thermocouple Types	Up to 20 channels, independently configurable for B, E, J, K, N, R, S or T
Thermocouple Inputs	The device reads mV signals from the supported Thermocouples. B = 0 to 13.82 mV E = -9.835 to 76.373 mV J = -8.095 to 69.553 mV K = -6.458 to 54.886 mV N = -4.345 to 47.513 mV R = -0.226 to 21.101 mV S = -0.236 to 18.693 mV T = -6.258 to 20.872 mV  Accuracy: +/- 1°C typical with cold junction compensation at ambient temperature or +/- 0.2°C without cold junction compensation Resolution: 0.001°C
Scan Rate	100ms per channel, total sweep time maximum 2.2 seconds
Common Mode Readings	Input range +/- 4V maximum Rejection is 100db at 5Vp-p (50-60Hz)
Thermal Drift	150 ppm/°C of span (maximum)
Isolation	Digital isolation is 500VDC from input to ground. Three way isolation is provided for the CAN line, inputs and power supply
Averaging	Available on Bank 1 (TC1 to TC10), Bank 2 (TC11 to TC20) and Total (All)
Protection	Open circuit detection Frozen data detection Over or under temperature detection High temperature shutdown detection

### Communication

CAN	1 CAN 2.0Bport, protocol CiA CANopen ® By default, the Thermocouple Scanner transmits the process value (object \$7130) according to the device profile in CiA Standard DS-404.  The CANopen® 20 Channel Thermocouple Scanner is compliant with the following CiA profiles. <ul style="list-style-type: none"> <li>• CiA DS-301 V4.1 – <i>CANopen® Application Layer and Communication Profile</i> (CAN in Automation 2005)</li> <li>• CiA DS-305 V2.0 – <i>Layer Setting Service (LSS) and Protocols</i> (CAN in Automation 2006)</li> <li>• CiA DS-404 V1.2 – <i>CANopen® profile for Measurement Devices and Closed Loop Controllers</i> (CAN in Automation 2002)</li> </ul> The documents are available from the CAN in Automation e.V. website <a href="http://www.can-cia.org">http://www.can-cia.org</a> .  Digital isolation is provided for the CAN line.
Network Termination	According to the CAN standard, it is necessary to terminate the network with external termination resistors. The resistors are 120 Ohm, 0.25W minimum, metal film or similar type. They should be placed between CAN_H and CAN_L terminals at both ends of the network.
RS-232	1 RS-232 port is available for debugging purposes. ASCII Text Format, 115200 Baud Rate Data – 8 bit, Parity – None, Stop – 1 bit. Flow Control – Xon/Xoff. Short circuit protection to ground.

## General Specifications

Microprocessor	MC56F8366, 16-bit, 512 kByte flash program memory
Control Logic	User programmable functionality using SDO object access, per CiA DS-301
Diagnostics	Available on mandatory object \$1003, Pre-Defined Error Field Additional information for diagnostic and testing purposes can be obtained using the RS-232 port and Tera Term.
Baud Rate	Default bit-rate is 125 kbit/s. Other bit-rates can be selected using Layer Setting Services.
User Interface	EDS provided to interface to standard CANopen® tools
Compliance	UL508 (April 2010) (FTPM2) – Controls for Stationary Engine Driven Assemblies cUL C22.2 No. 14-18 (2018)
CSA	Class I, Division 2, Groups A, B, C, D T4 It must be installed in an explosion proof enclosure. Refer to Control Drawing 041715 Rev D.
ATEX Certificate	Certificate number: Sira 15ATEX4138X Class I, Zone 2, II 3G Ex nA IIC T4 Gc, Ta = -40°C to +70 °C IEC 60079-0: 2012/A2013 IEC 60079-15: 2010 Completed testing to IP54 which means it does not need to be in an explosion proof enclosure.
CE Compliance	2004/108/EC (EMC Directive) 2011/65/EU (RoHS Directive)
Marine Type Approvals	Lloyd's Register (LR), DNV-GL, ABS, RINA, BV, CCS, RS The AXTC20CO meets the environmental, EMC and vibration requirements of generator set applications in marine installations.
Operating Temperature Range	-40 to 85 °C (-40 to 185 °F)  For use in hazardous locations, the operating temperature range is: -40 to 70 °C (-40 to 158 °F)
Storage Temperature Range	-50 to 120 °C (-58 to 248 °F)
Humidity	Protected against 95% humidity non-condensing, 30 °C to 60 °C
Protection	IP67 Pollution Degree 3 per UL508 <i>The marine type approval process tested to IP56.</i> IP54 rating for use in hazardous locations (tested by CSA.)
Vibration	8 G for a rail mounted and vibration isolated device <i>The marine type approval process tested to 4.0 G per IEC 60068-2-6, Test Fc (2007).</i>
Weight	2.2 lbs. (1.00 kg)
Enclosure	Rugged aluminum housing, stainless steel end plates, neoprene gaskets 145.30 x 149.00 x 73.00 mm (5.72 x 5.86 x 2.87") L x W x H Connectors, Deutsch IPD P/N: 1 8-pin DT13-08PA, 1 40-pin DRC13-40PA Can be mounted directly on the power generator set or remotely.

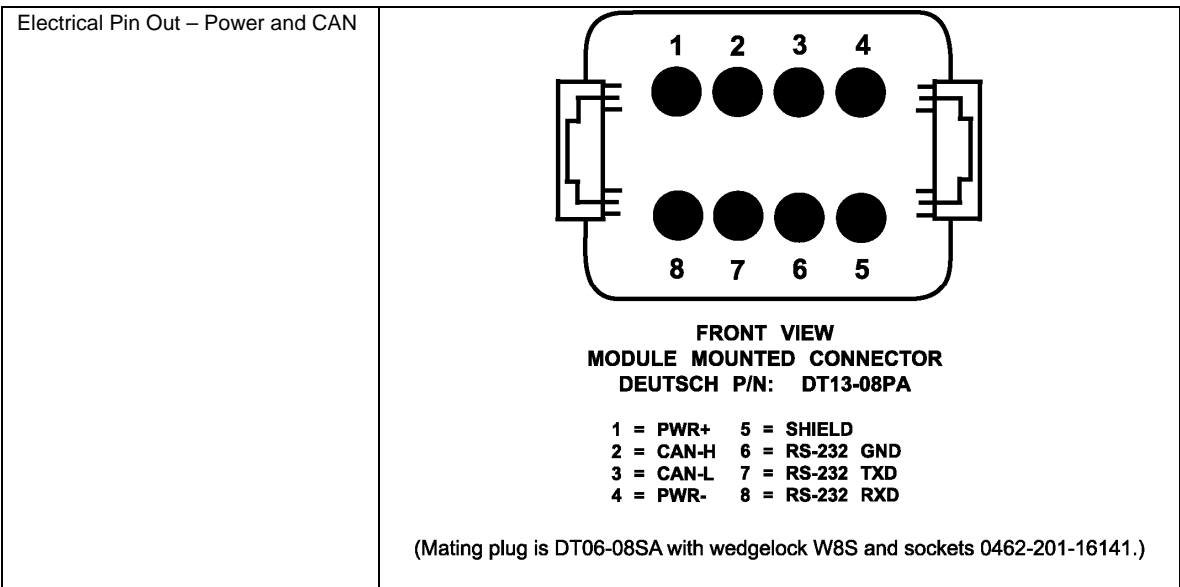
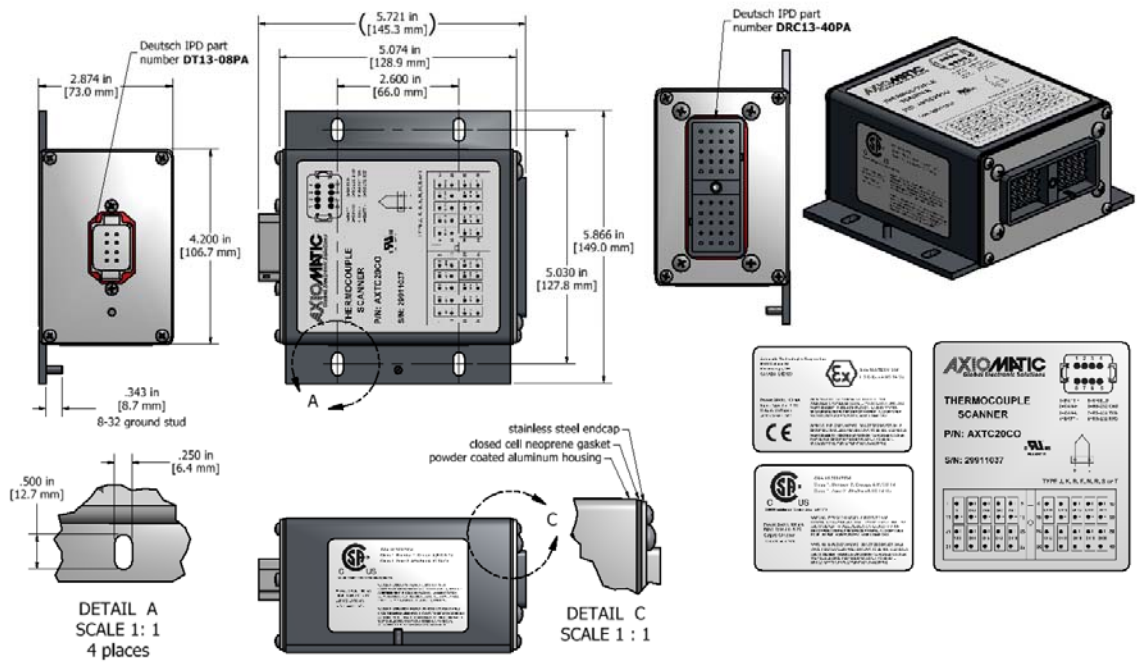

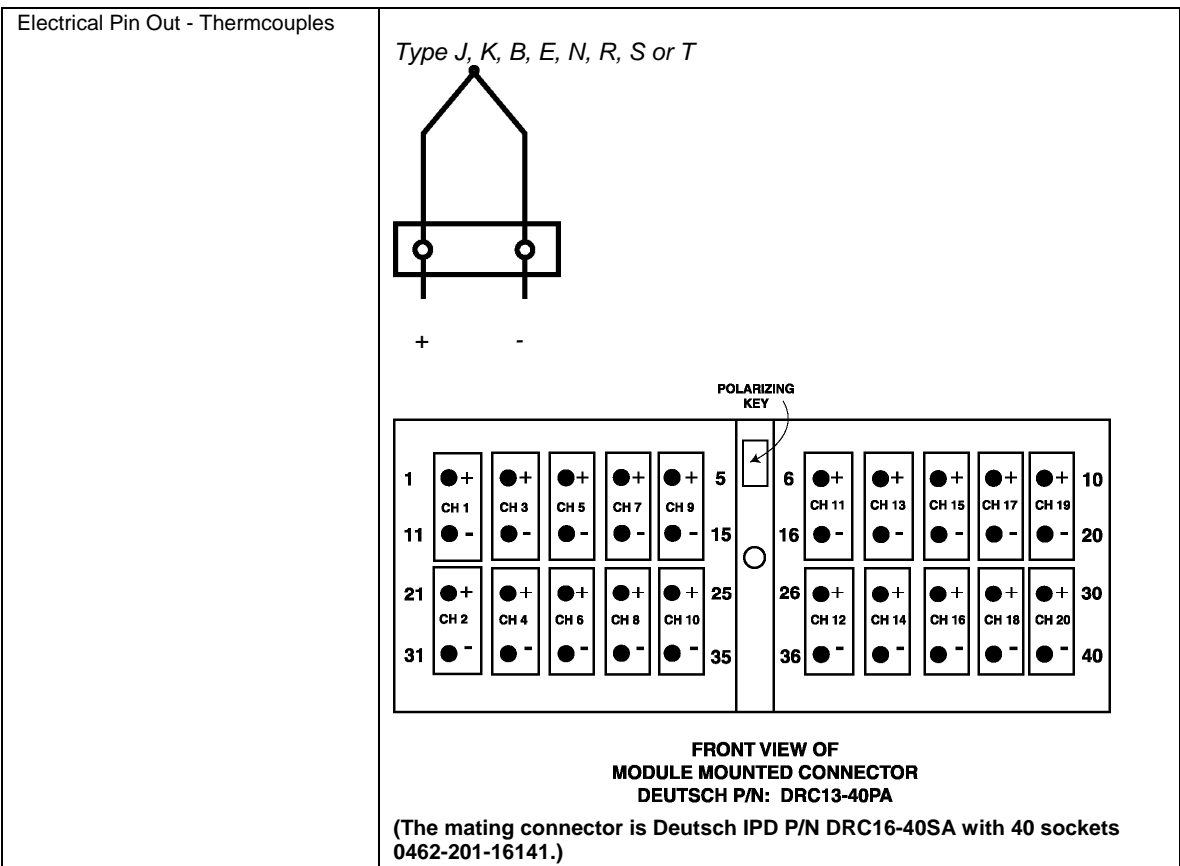

Note: CANopen® is a registered community trade mark of CAN in Automation e.V.

*Specifications are indicative and subject to change. Actual performance will vary depending on the application and operating conditions. Users should satisfy themselves that the product is suitable for use in the intended application. All our products carry a limited warranty against defects in material and workmanship. Please refer to our Warranty, Application Approvals/Limitations and Return Materials Process as described on [www.axiomatic.com/service.html](http://www.axiomatic.com/service.html).*

TDAXTC20CO-11/20/18