

TECHNICAL DATASHEET #TD3005AX  
**DC-DC Converter**  
 (72 VDC to 12 VDC)  
 P/N: SMP-BAC-72VD-12VD-01

**Clean 12 VDC power in a rugged package**

- Accepts 35 to 90 VDC (72V nominal)
- Conditioned output of 12 VDC with low ripple
- High current output capability (15 A nominal, 20 A peak)
- Switch mode operation delivers very high efficiency >93%
- Design manages heat dissipation avoiding forced cooling
- Reverse polarity protection
- Short circuit protection
- Robust, rugged and highly reliable
- Compact size for ease of mounting in confined spaces
- Suitable for moist, high shock and vibration environments
- Operational from -30 to 74°C
- IP67 protection
- Low emissions



**BLOCK DIAGRAM**

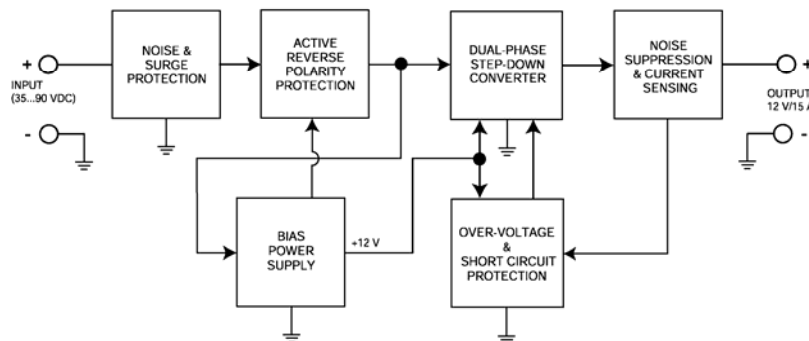

**Application:**

Designed to interface between 72V batteries and 12V electrical systems such as 12V solenoids, relays and other electrical systems.

**Description:** The DC-DC Converter provides clean power suitable for 12VDC electrical systems used in telecommunications and mobile equipment/vehicle applications. For operation under the most harsh and demanding conditions, the IP67 rated unit is fully sealed and potted in an enclosure to protect against moisture, shock and vibration. Power from a battery or other source of 72VDC is converted to a 12 VDC output regulated to 0.5%. The unit has a high current output capability of 15 Amp nominal (20 Amp peak). The device manages heat dissipation and requires no forced cooling systems. Short circuit and reverse polarity protection are provided. The compact unit is designed with extremely rugged surge and transient suppression in addition to sustained over/under voltage protection. With a nameplate rating of 180 VA of output power, the DC-DC Converter features proprietary dual-phase topology for a high efficiency of >93%.

**Ordering Part Numbers:**

Converter with Wire Harness KIT:

**PSU18K** (KIT SMP-BAC-72VD-12VD-01 Converter, WH-DTP06-4S-S-2M Wire Harness)

Items can also be ordered individually.

Converter: **SMP-BAC-72VD-12VD-01**

Mating Wire Harness, 2 m: **WH-DTP06-4S-S-2M**

## Technical Specifications:

All specifications are typical at nominal input voltage and 25 degrees C unless otherwise specified.

Input Specifications		Output Specifications	
Operating Voltage Range	35 to 90 VDC (72 VDC nominal)	Nameplate Rating (Output Power)	180 VA nominal
Maximum Input Current	3A <sub>DC</sub> @ 73 VDC, 15 A I-output 6A <sub>DC</sub> @ 35 VDC, 15A I-output	Output Current (DC)	15 A continuous (20 A peak)
Inrush Current	None	Output Voltage	12 VDC $\pm$ 3%
Reverse Voltage Protection	Provided	Output Voltage Ripple	V <sub>O(RIPPLE)</sub> $\leq$ 100 mVpp
Over-voltage Protection	Provided	Turn-on Time (with full load)	100 msec. Maximum / 5% of final value
Under-voltage Protection	Provided	Turn-on Overshoot	None
		Stability	Stable at all load conditions (no minimum load required)
		Transient Response	200 mV/1.5 ms (No Load to Full Load) 100 mV/1 ms (50% - 100% Load)
		Short Circuit Protection	Provided
		Overload Protection	Output foldback to 10 A @ 0 Ohms
General Specifications			
Efficiency	>93%		
Operating Temperature	-30 to 74°C (-20 to 165°F)		
Storage Temperature	-40 to 85°C (-40 to 185°F)		
Humidity	0-99% relative humidity (non-condensing)		
Protection rating	IP67		
Electrical Connection	4 pin Deutsch connector P/N: DTP04-4P-L012 Power +, Power – Output +, Output – See page 3 for pinout. A mating plug assembly with 12 AWG unterminated lead wires is available. Ordering P/N: WH-DTP06-4S-S-2M (The mating plug assembly is comprised of Deutsch P/N: DTP06-4S, WP4S and four contact sockets 0462-203-12141 with 2 meters (6.5 ft.) of 12 AWG lead wire, unterminated.) Contact the manufacturer for application-specific wiring.		
Weight	1.4 kg (3.08 lbs.)		
Dimensions	5.50 x 6.77 x 2.37 inches (W x L x H) 139.7 x 172.0 x 60.3 mm		
Installation			
<b>Set up</b>			
<ol style="list-style-type: none"> <li>1. A maximum 15A fuse is recommended in the primary circuit to provide protection for the primary wiring.</li> <li>2. Use four ¼-20 1 inch screws to mount the converter.</li> <li>3. Snap the mating plug connector with wiring harness into the receptacle mounted on the converter.</li> </ol> <p>Once the load is ready to receive power, turn on the power source to the converter.</p>			

<p><b>Grounding</b></p>	<p>Protective Earth (PE) must be connected to the grounding stud to reduce the risk of electric shock. The conductor providing the connection should have a ring lug and wire larger than or equal to 4 mm<sup>2</sup> (12 AWG). The ring lug should be placed between the nut and a star washer. (To secure the ground strap, use an 8-32 "K-LOK" locknut, stainless steel, 3/8" O.D.)</p> <p>All chassis grounding should go to a single ground point designated for the machine and all related equipment.</p> <p>The ground strap that provides a low impedance path for EMI should be a ½ inch wide, flat, hollow braid, no more than 12 inches long with a suitable sized ring lug for the module's grounding lug. It may be used in place of the PE grounding conductor and would then perform both PE and EMI grounding functions.</p>
<p><b>Mounting</b></p>	<p>Mounting ledges include holes sized for ¼ inch or M6 bolts. The bolt length will be determined by the end-user's mounting plate thickness. Typically ¾ inch (20 mm) is adequate.</p> <p>If the module is mounted without an enclosure, it should be mounted vertically with connectors facing left and right to reduce likelihood of moisture entry.</p> <p>All field wiring should be suitable for the operating temperature range of the module.</p> <p>Install the unit with appropriate space available for servicing and for adequate wire harness access (6 inches or 15 cm) and strain relief (12 inches or 30 cm).</p>
<p><b>Mechanical Drawing</b></p> <p style="text-align: center;">Dimensions: inches [mm]</p>	<p><b>Pin Out</b></p> <ol style="list-style-type: none"> <li>1 Input + (red)</li> <li>2 Output + (red/white)</li> <li>3 Output - (black/white)</li> <li>4 Input - (black)</li> </ol>

Specifications are subject to update without notice.  
Form: TD3005AX-11/15/07  
©2007 Axiomatic Technologies Corporation