

# 3 AMP SOLENOID DRIVER

User Selectable V or mA Input  
 Bipolar or Unipolar 0-3A Output  
 Adjustable Dither and PWM Frequency  
 PCB Board or Packaged in Metal Housing  
**P/N: RSD-x-3A-y**

Where x = PCB – card style  
 SMB – metal box style with 1.5m cable  
 y = 00 – metal box style with strain reliefs  
 01 – 3 connectors

**Description:** The 3 Amp Solenoid Driver simplifies control of proportional solenoids by supplying a current proportional to a user selectable input control. It is suited for industrial applications interfacing with a PLC. The available inputs include: 0-2.5V, 0 to +/- 2.5V, 0-5V, 0 to +/-5 V, 0-10V, 0 to +/-10V, 0 to +/-20V, 4-20 mA, and 0-20 mA. The controller accepts power supply voltages from 8 to 28 VDC. This linear solenoid driver utilizes high frequency switching output (PWM) to provide a DC current output. Output is user selectable as 0 to 3 Amps or 0 to +/- 3 Amps. A current sensing circuit maintains output current regardless of changes in input voltage and coil resistance. The user can adjust PWM frequency, maximum current, minimum current, a superimposed dither frequency and amplitude using single turn trim potentiometers. A sine, square or triangle dither waveform is user selectable. An auxiliary output permits monitoring of current output with a voltmeter with a scale of +/-1V/1A. The unit is available as a stand alone PCB Board or as a Packaged Driver enclosed in an IP67 rated metal housing with cable or strain reliefs. It is designed for mounting close to the valve. Other versions are available with a 2A maximum current output including a remote mount driver with filter and various DIN 43650 coil mount models.

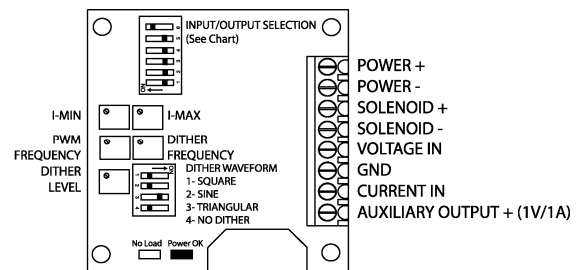

P/N: RSD-SMB-3A-00 is shown above without its metal housing. The PCB only model p/n: RSD-PCB-3A has the 8-pin connector reversed to permit wiring from the right hand side.

## Features:

- Suitable for industrial hydraulic applications with PLC interface
- Accepts a wide range of power supply inputs from 8 to 28 VDC
- Selectable command input (0-2.5V, 0 to +/-2.5V, 0-5V, 0 to +/-5 V, 0-10V, 0 to +/-10V, 4-20 mA, 0-20 mA)
- Modern technology utilizing adjustable high frequency switching output (PWM) – adjustable to suit individual valves
- Maximum current output is regulated and adjustable
- Output is user selectable for 0-3A or 0 to +/-3 Amps
- Maximum current adjustment does not affect minimum current setting (all trim pots are multi-turn)
- Current sensing circuit maintains output current regardless of changes in supply voltage and coil resistance changes with temperature
- Auxiliary output permits monitoring of current output with a voltmeter (+/-1V/1A)
- Energy efficient design (no heat sink is required)
- Superimposed dither is user adjustable for frequency, amplitude and waveform (sine, square or triangle)
- LEDs indicate Power OK and No Load condition
- Electronic limiting circuit means no internal fuses
- Short circuit proof
- Stand alone PCB card with screw terminal connections
- Metal box version carries IP67 rating and is available with 1.5 meters of shielded cable or 3 connectors
- Metal box version with strain reliefs permits user to wire into screw terminals inside
- Designed for mounting close to the valve

## Ordering Part Numbers:

**PCB Board** - RSD-PCB-3A

**Packaged Driver with cable** – RSD-SMB-3A

**Packaged Driver with strain reliefs** – RSD-SMB-3A-00

**Packaged Driver with 3 connectors** – RSD-SMB-3A-01

**Technical Specifications:** All specifications typical at nominal input voltage and 25°C unless otherwise specified.

## General Specifications

Operating conditions	<i>Model RSD-PCB-3A:</i> -40 to +85 degrees C (-40 to 185°F)
Storage temperature	<i>Models RS-SMB-3A-XX:</i> -40 to +75 degrees C (-40 to 167°F) 0 to 85% relative humidity -50 to +125 degrees C (-58 to 257°F)
LED indicators	Green LED – ON indicators Power OK Red LED – OFF indicates load is connected Red LED – ON – indicates a no load condition
Electrical connection - PCB Board	8 screw terminals Use 14-16 AWG wiring for Power and Solenoid output wiring. Use a shielded cable for connection to the solenoid.
Electrical connection - Packaged Driver with cable	Unterminated shielded cable 5 ft. (1.5m) standard length
Cable clamp (grommet) size (Packaged Driver) Max. cable diameter	PG9 screw type 5.00 to 7.92 mm (0.200 to 0.312 in.)
Electrical connection - Packaged Driver with 3 connectors	<i>Solenoid</i> - Brad Harrison 45360-001 nano-change receptacle (3-pole male) Use a shielded cable to connect to the solenoid. <i>Signal Input</i> - Brad Harrison 45360-001 nano-change receptacle (3-pole male) <i>Power Input</i> – Brad Harrison 8R4E06A18A120 micro-change single keyway receptacle (4-pole male)
Protection - Packaged Driver	IP67 with nitrile lid gasket and cable installed
Dimensions - PCB Board	63.5 x 20.3 x 63.5 mm (W x D x H) 2.5 x 0.8 x 2.5 inches
Dimensions - Packaged Driver with cable or strain reliefs	114.3 x 27.9 x 79.4 mm 4.50 x 1.01 x 3.13 inches (W x D x H excluding grommet and cable)
Dimensions - Packaged Driver with 3 connectors	114.3 x 39.0 x 110.64 mm 4.50 x 1.53 x 4.35 inches (W x D x H including mounting plate and connectors)
Weight (PCB)	0.10 lbs. (0.04 kg)

**DIMENSIONS OF METAL BOX AND PCB VERSIONS**

**METAL BOX WITH CABLE**

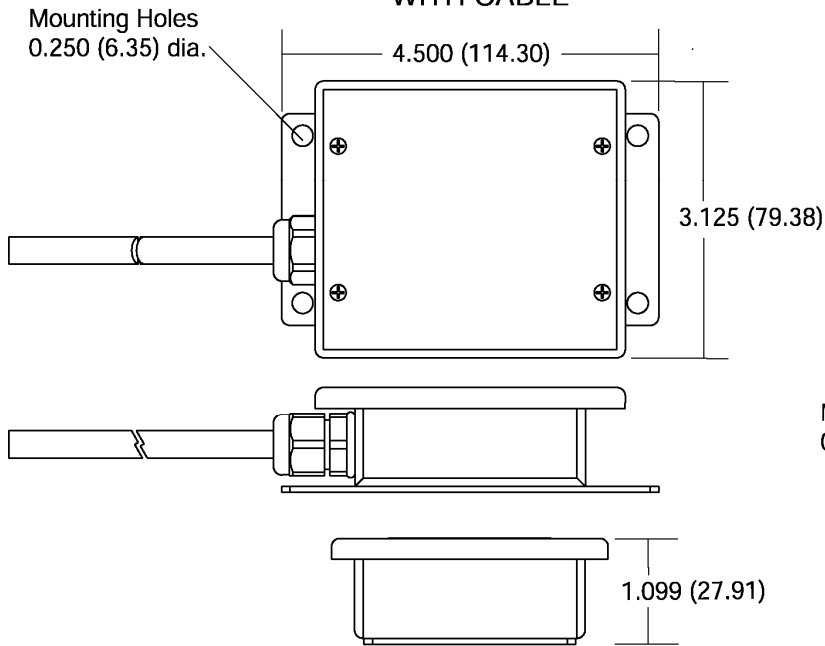

**PCB BOARD**

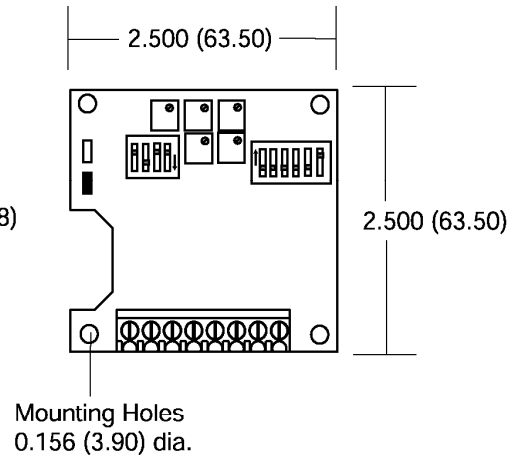

Dimensions: inches (mm)

**DIMENSIONS OF METAL BOX WITH 3 CONNECTORS (CONNECTORS NOT SHOWN)**

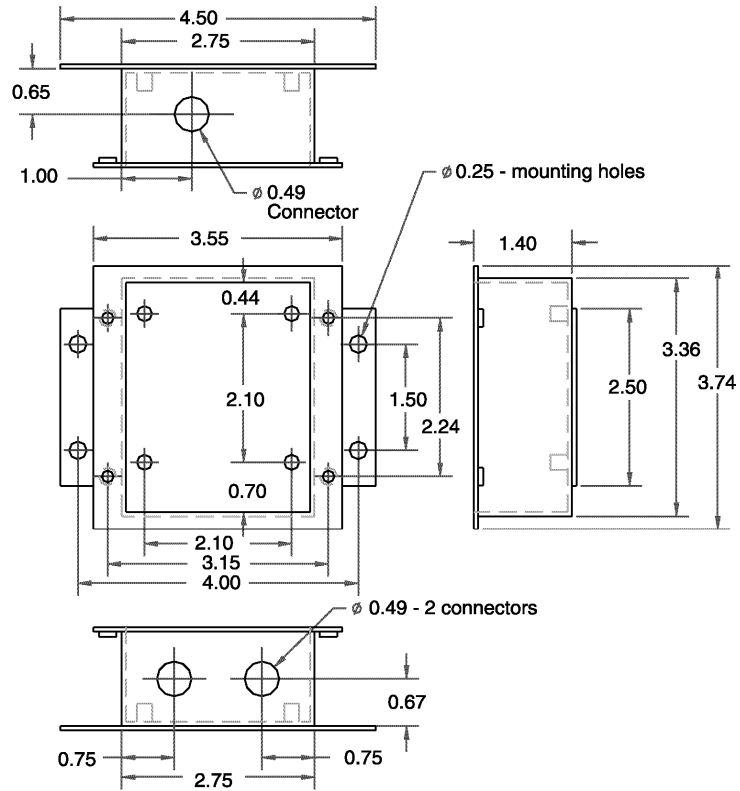

Dimensions: inches

## Electrical Specifications

Operating voltage (power supply requirement)	8 to 28 VDC power supply range (12 V nominal)
Control input signal options	User selectable 0-2.5VDC, 0 to +/-2.5VDC 0-5VDC, 0 to +/-5VDC 0-10 VDC, 0 to +/-10VDC 4-20 mA, 0-20 mA (Refer to DIP Switch settings chart)
Input resistance	Voltage mode: 100K Ohms Current mode: 286 Ohms
Input protection	+/- 50 VDC
Range of maximum output current (regulated)	User selectable 0 to 3 A, 0 to +/- 3A
Compliance voltage	$V_{PS} - 1V$
Short circuit protection	Provided on output
Load connection	Ungrounded, floating load
Auxiliary output	Voltage output is proportional to current output. Short circuit protection is provided.
Auxiliary output scale	+/-1V per 1A

Note 1: For proper operation, match the power supply voltage with rating of solenoid coil. Operating the driver with a supply voltage lower than the solenoid rated voltage may result in reduced maximum current output.

Note 2: The coil should have no polarity or protection diodes for proper operation of the device.

Note 3: The maximum current output of the driver should not exceed the current rating of the solenoid coil.

## Adjustments

All potentiometers are multi-turn.

	Range	Factory Setting
Minimum current	-1A to +1A	0 Amps (midpoint)
Maximum current	1 to 3A or -1 to -3 A User selectable with DIP Switch 1	100%
Dither amplitude (level)	<u>Adjustment range @ 44 Hz</u> Square: 0 to 912 mA <sub>PK-PK</sub> Sine: 0 to 848 mA <sub>PK-PK</sub> Triangular: 0 to 776 mA <sub>PK-PK</sub>	0%
Dither waveform Dither selection	User selectable with DIP Switch 2 1- ON – Square 2- ON – Sine 3- ON – Triangular 4- ON – No Dither selected	3 – ON Triangular
Current dither frequency	<u>Adjustment range @ 400 mA<sub>PK-PK</sub></u> Square: 44 Hz to 217 Hz Sine: 44 Hz to 188 Hz Triangular: 44 Hz to 163 Hz	Minimum (44 Hz)
PWM frequency	16 kHz to 60 kHz +/-10%	Maximum (60 kHz)

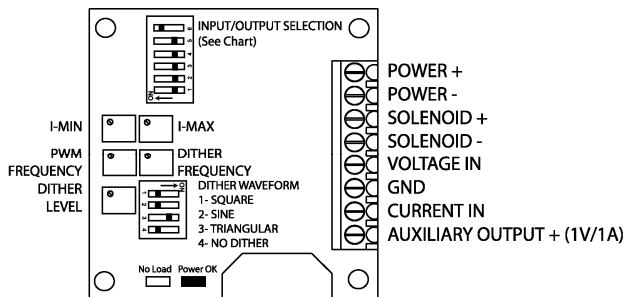

Adjusting the minimum current will shift the maximum current setting, as shown.

Adjusting the maximum current (I-max.) does not affect the minimum current (I-min.) setting.

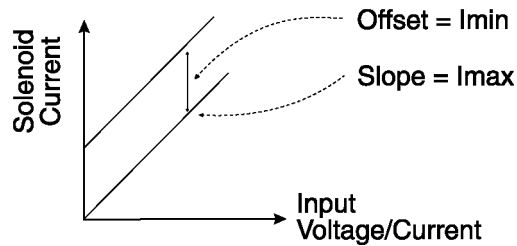

### Setting the Minimum Current (I-min.)

The minimum current setting can be used to take into account the mechanical valve deadband and provide desired offsets from zero to allow full control within the functional range of the specific valve.

- **Set the minimum current before setting the maximum current.**
- Apply minimum input (in the case of 0-5V, 0 V).
- The factory setting for the I-min. trim pot is set at 0 Amps or midpoint.
- If the desired minimum current is greater than 0, adjust the trim pot clockwise (CW) until the desired current is achieved.

### Setting the Maximum Current (I-max.)

- Apply maximum control (in the case of 0-5V, 5 V).
- The factory setting for the I-max. trim pot is 100%.
- Turn the trim pot to adjust the current setting to the desired maximum.

The maximum current setting is adjusted to meet the customer's working pressure or flow range to the full scale signal input range. This provides maximum control for a specific application.

## Mounting Instructions and Wiring Connections

### For PCB cards:

#### Mounting the PCB board

- The board will accommodate #6 size mounting screws (not supplied).

#### Connecting to the screw terminals on the board

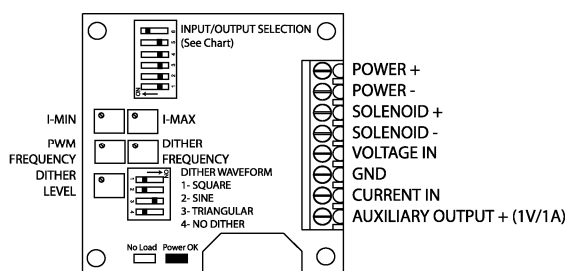

- Reference the label (included with the board) for the pin out connections of the screw terminals.
- Chassis ground connections can be made to the Power – terminal.
- Use a cable to connect to the PCB board with each wire stripped to 6.5 mm (1/4 inch) and the shield (jacket) stripped to permit splaying of the wires in the screw terminals without tension. The exposed ground shield wire should have a heat shrink placed around the wire as a precautionary measure.
- To connect the cable to the board, loosen each screw terminal, insert the pre-tinned wire and tighten with a jeweller's sized screwdriver. Take care to position the ground shield wire away from the PCB Board.
- The auxiliary output is used to allow connection of a voltmeter to indicate the level of the output current where the scale is 1V = 1 Amp.

**For Packaged Drivers with cable (Metal Box):**

**Mounting the housing**

Mount the housing using four #10-32 bolts or screws.

**Wiring Connections**

**3 Amp Solenoid Driver (Metal box with shielded cable - IP67 rating)**

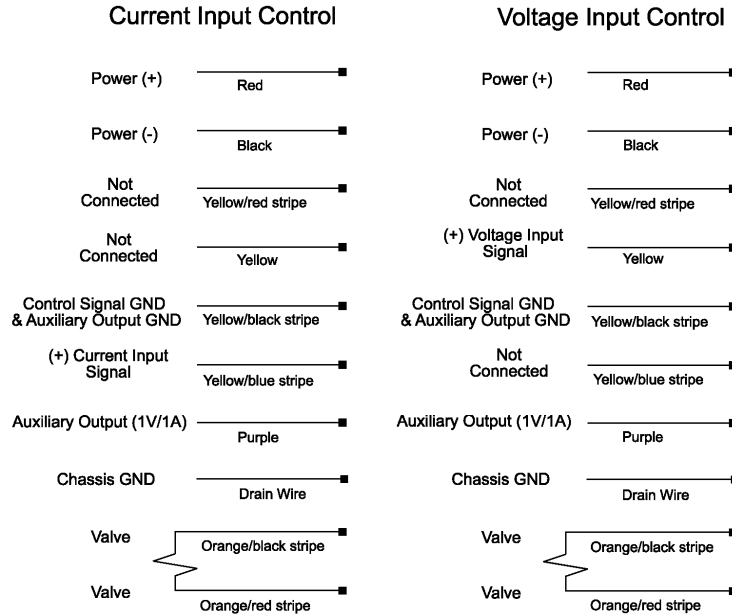

**Connecting the cable**

Connect the shielded cable to the load, power supply and input signal as follows. The drain wire from the shielded cable is connected to the particular Chassis GND for the application. The auxiliary output is used to connect to a voltmeter to indicate the level of the output current where the scale is 1V = 1 Amp.

**For Packaged Drivers with 3 connectors (larger Metal Box):**

**Mounting the housing**

Mount the housing using four #10-32 bolts or screws.

**Connector Pin Out:**

The pin out shown below is for three male connectors mounted in the metal box. Use a shielded cable to connect to the solenoid and connect its drain wire to Pin 1 on the solenoid connector in the metal box.

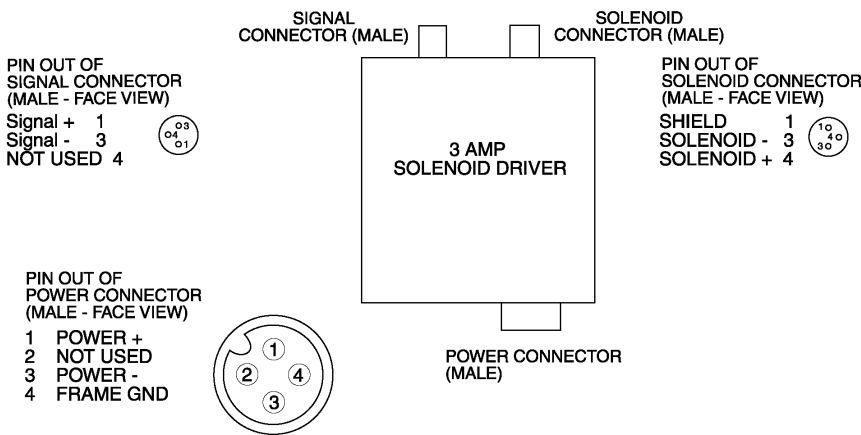

## Selecting The Input Signal and The Output

Using the Input/Output Selection Dip Switch, the following configurations are user selectable.

Switch 1 ON	Range 1	Range 2
Input Range	-5V → 0V → +5V	0V → +5V
Output Range	-3A → 0A → +3A	0A → +3A

Switch 1 & 4 ON	Range 1
Input Range	-2.5V → 0V → +2.5V
Output Range	0A → +1.5A → +3A

Switch 1 & 5 ON	Range 1
Input Range	-2.5V → 0V → +2.5V
Output Range	-3A → -1.5A → 0A

Switch 2 ON	Range 1	Range 2
Input Range	-10V → 0V → +10V	0V → +10V
Output Range	-3A → 0A → +3A	0A → +3A

Switch 2 & 4 ON	Range 1
Input Range	-5V → 0V → +5V
Output Range	0A → 1.5A → +3A

Switch 2 & 5 ON	Range 1
Input Range	-5V → 0V → +5V
Output Range	-3A → -1.5A → 0A

Switch 3 ON	Range 1	Range 2	Range 3
Input Range	-20V → 0V → +20V	0V → +20V	-10V → 0V → +10V
Output Range	-3A → 0A → +3A	0A → +3A	-1.5A → 0A → +1.5A

Switch 3 & 4 ON	Range 1
Input Range	-10V → 0V → +10V
Output Range	0A → +1.5A → +3A

Switch 3 & 5 ON	Range 1
Input Range	-10V → 0V → +10V
Output Range	-3A → -1.5A → 0A

Switch 6 ON	Range 1
Input Range	4mA → 20mA
Output Range	0A → +3A

Switch ALL OFF	Range 1
Input Range	0mA → 20mA
Output Range	0A → +3A

Specifications are indicative and subject to change. Actual performance will vary depending on the application and operating conditions. Users should satisfy themselves that the product is suitable for use in the intended application. All our products carry a limited warranty against defects in material and workmanship. Please refer to our Warranty, Application Approvals/Limitations and Return Materials Process as described on [www.axiomatic.com/service.html](http://www.axiomatic.com/service.html).

Form: TD1516AX-11/19/12