

## 2 Universal Inputs, Dual Valve Controller

2 Universal Inputs

2-3A Outputs

CAN (SAE J1939)

Configurable with Electronic Assistant®

P/N: AX023220

### Features

- 2 universal signal inputs configurable as:
  - Voltage
  - Current
  - Resistive
  - PWM Duty Cycle
  - Frequency/RPM
  - Encoder
  - or Digital
- 2 proportional/digital outputs configurable as:
  - Proportional Current
  - Proportional Voltage
  - Proportional PWM (*selectable frequency from 1Hz to 25kHz*)
  - Hotshot Digital
  - or On/Off Digital
- 1 +5V Reference
- Fully protected outputs
- 12V or 24Vdc nominal
- Operational up to 125°C temperature
- Developed with Simulink®
- Software filtering for input types
- Multiple logic function blocks provided to allow for a wide variety of applications
- Configurable software output shutdowns provided on Power Supply faults
- J1939-73 Diagnostics
- Flexible user customization for application-specific control logic via the CAN based Electronic Assistant®.
- 1 CAN (SAE J1939) port (CANopen® on request)
- 250kbps, 500kbps and 1Mbps models available
- Rugged IP67 packaging and connectors
- CE marking



### Applications

The controller is designed to meet the rugged demands of mobile equipment, marine and heavy duty industrial machine applications. These applications include, but are not limited to:

- **Proportional Fan Drive Control**
- PID Closed Loop Valve Control
- Hydraulic Valve Control
- Signal Conversion

### Ordering Part Numbers:

Actuator Controller, SAE J1939 250 kbps P/N: **AX023220**  
Actuator Controller, SAE J1939 500 kbps P/N: **AX023220-01**  
Actuator Controller, SAE J1939 1 Mbps P/N: **AX023220-02**

### Accessories:

**PL-DTM06-12SA** Mating Plug Kit  
Electronic Assistant® Configuration KIT: **AX070502**

## Description:

The Dual Input, Dual Output Valve Controller (2i2o) is designed for extremely versatile control of up to two proportional outputs to directly drive coils or other loads. Its flexible circuit design gives the user a wide range of configurable input or output types. The sophisticated control algorithms allow the user to program the controller for a wide range of applications without the need for custom software.

The controller has two fully configurable universal inputs that can be setup to read: voltage, current, resistive, frequency, or digital input signals. There are also two universal outputs that can be setup to drive: proportional current (up to 3A each); hotshot digital current; proportional voltage (up to supply); proportional PWM; or straight on/off digital loads. All I/O ports on the unit are independent from one another.

The 2i2o is a highly programmable controller, allowing the user to configure it for their application. Its sophisticated control algorithms allow for open or closed loop drive of the proportional outputs. It can be operated as either a self-contained control system, driving the outputs directly from the on-board inputs, and/or it can be integrated into a CAN J1939 network of controllers. All I/O and logical function blocks on the unit are inherently independent from one another, but can be programmed to interact in a large number of ways. While the Block Diagram shows the hardware features, Figure 1 shows the logical function blocks (software) available on the 2i2o.

The 2i2o has a number of built-in protection features that can shut off the outputs in adverse conditions. They include hardware shutoffs to protect the circuits from being damaged as well as software shutdown features that can be enabled in safety critical systems.

All setpoints are user configurable using the Electronic Assistant®.

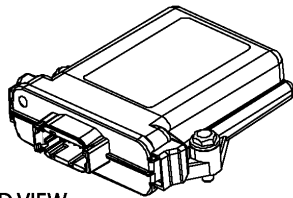

3D VIEW  
12 Pin Receptacle

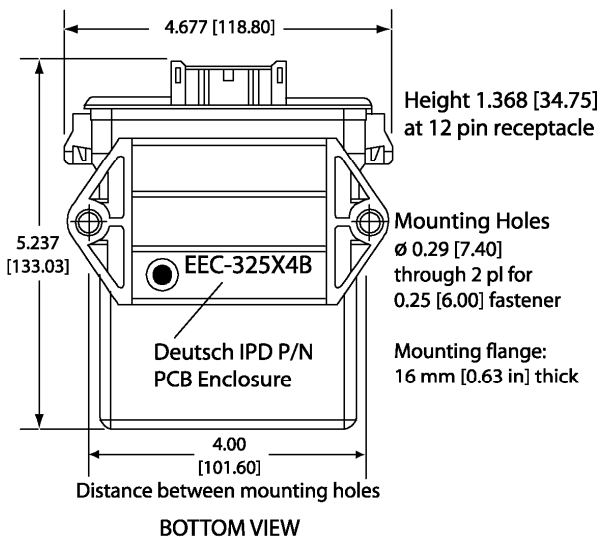

## HOUSING DIMENSIONS

Housing Material: High Temperature Nylon (Black)  
Protection Rating: IP67

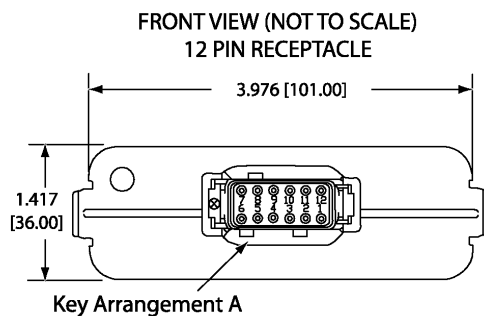

Mating Plug Assemblies:  
12 pin receptacle - DTM06-12SA with wedgelock WM12S and contacts  
24 pin receptacle - DTM06-12SA and DTM06-12SB with wedgelocks WM12S and contacts  
Contact factory for contact specification.

Dimensions: inches [mm] excluding mating plug(s)

## Technical Specifications:

### Inputs

Power Supply Input - Nominal	12 or 24VDC nominal (9...60 VDC power supply range)
Protection	Reverse polarity protection is provided. Surge protection up to 65V is provided. Overvoltage shutdown of the output load is provided. Undervoltage protection (hardware and software shutdown at 7.5V) is provided.
CAN	SAE J1939 Commands 500 kbps and 1 Mbps baud rate models are available. See Ordering part numbers.
Voltage Reference	One provided 5V +/- 0.2% error Can source up to 50mA without derating
Analog GND Reference	One provided
Universal Signal Inputs	2 fully independent universal inputs are provided. Refer to Table 1.0 All inputs are user selectable as Voltage, Current, Resistive, Frequency, RPM, PWM, Encoder or Digital input types. Inputs are sampled multiple times per millisecond. Protected against shorts to GND or +Vps (up to 60 Vdc) All input channels can handle negative voltage inputs down to -2VDC due to voltage spikes or noise. Response time to change at the input 2 mSec +/- 1 mSec (without software filtering) unless otherwise noted.

Table 1.0 – Input – User Selectable Options	
Analog Input Functions	Voltage Input, Current Input or Resistive Input 12-bit Analog to Digital
Voltage Input	0-1V (Impedance 1 M $\Omega$ ) 0-2.5V (Impedance 1 M $\Omega$ ) 0-5V (Impedance 135 k $\Omega$ ) 0-10V (Impedance 127 k $\Omega$ ) 1mV resolution, accuracy +/- 1% error
Current Input	0-20 mA (Current Sense Resistor 249 $\Omega$ ) 4-20 mA (Current Sense Resistor 249 $\Omega$ ) 1 $\mu$ A resolution, accuracy +/- 2% error
Resistive Input	Self-calibrating for range of 30 $\Omega$ to 250 k $\Omega$ 1 $\Omega$ resolution, accuracy +/- 1% error Slower response time is due to the auto-calibration feature. It could take up to ~2 Sec. for the input reading to stabilize after a large change (i.e. 50 $\Omega$ to 200k $\Omega$ ) at the input, or to detect an open circuit. <i>It is recommended to use software filtering type Moving Average with Filter Constant 100 for this input type.</i>
Digital Input Functions	Discrete Input, PWM Input, Frequency Input, RPM Input 15-bit timer (PWM, Frequency, RPM)
Digital Input Level	12V
PWM Input	0 to 100% Low Frequency (<1kHz) or High Frequency (>100 Hz) 0.01% resolution, accuracy +/- 1% error 1M $\Omega$ Impedance, or 1k $\Omega$ Pullup/10k $\Omega$ Pulldown <i>Response time is dependent on input frequency.</i>
Frequency/RPM Input	0.5 to 50Hz Range: 0.01Hz resolution 10Hz to 1kHz Range: 0.1Hz resolution 100 Hz to 10kHz Range: 1Hz resolution Accuracy +/- 1% error 1 M $\Omega$ Impedance, or 10 k $\Omega$ Pullup/Pulldown Input debouncing selectable <i>Response time is dependent on input frequency.</i>
Digital Input	Normal, Inverse or Latched (pushbutton) Configurable 1k $\Omega$ pullup or 10k $\Omega$ pulldown resistor (to GND) resistor which can also be disabled (floating input) Rising/Falling edge threshold 2.0V +/- 0.1V Input debouncing time selectable

## Outputs

CAN	SAE J1939 Messages
Universal Outputs	<p>Two independent software controlled outputs selectable as: Proportional Current; Hotshot Digital; PWM Duty Cycle; Proportional Voltage; or On/Off Digital types</p> <p>Half-bridge outputs, current sensing, grounded load. High side sourcing up to 3A</p> <p>All output types have configurable minimum and maximum output levels within the range for the type selected.</p> <p>Current Outputs: 1mA resolution, accuracy +/- 2% error Software controlled PID current Range 0 to 3000 mA Fully configurable dither superimposed on top of output current Configurable from 50 to 400Hz amplitude High frequency output drive at 25kHz</p> <p>Voltage Outputs: 0.1V resolution, accuracy +/- 3% error Average voltage output based on unit power supply High frequency drive at 25kHz Additional external filtering is required to create a DC voltage</p> <p>PWM Outputs: 0.1% resolution, accuracy +/- 1% error Range 0 to 100% Output Frequency: 1 Hz to 25 kHz Configurable frequency ONLY if no current output types are used, otherwise default 25kHz is used</p> <p>Digital On/Off: Load at supply voltage must not draw more than 3A.</p>
Response Time	Contact Axiomatic.
Protection	Fully protected against short circuit to ground or +Vps Grounded short circuit protection will engage at 4.5A +/- 0.5A. Unit will fail safe in the case of a short-circuit condition, and is self-recovering when the short is removed.
Power GND Reference	One Provided

## General Specifications

Quiescent Current	109 mA @ 12Vdc Typical; 66 mA @ 24Vdc Typical
Microprocessor	TI TMS320F2806x, 32-bit, 256 KB flash program memory, 100 KB RAM
EMC Compliance	CE marking
Vibration	Random Vibration: 7.7 Grms peak Sinusoidal Component: 10 g peak Based on MIL-STD-202G, Methods 204G and 214A
Diagnostics	Each input and output channel can be configured to send diagnostic messages to the J1939 CAN network if the I/O goes out of range. Diagnostic data is stored in a non-volatile log. Refer to the User Manual for details.
Additional Fault Feedback	There are several types of faults that the controller will detect and provide a response: unit power supply undervoltage and overvoltage, microprocessor over temperature and lost communication. They can be sent to the J1939 CAN bus.
Control Logic	User configurable functionality using Electronic Assistant® service tool Refer to the User Manual for details.
Communications	Compliant to SAE CAN J1939 Standard 1 CAN port (SAE J1939) CANopen® is available on request.
CAN User Interface	Compliant to SAE CAN J1939 Standard  Interfaces with the Electronic Assistant®, P/N: AX070502, for Windows operating systems. It comes with a royalty-free license for use. To use the Electronic Assistant, an USB-CAN converter links the device's CAN port to a Windows-based PC.
CAN Response Time	Per the J1939 standard, the maximum recommended transmit rate for any message is 10ms. Response time of feedback on the CAN to changes at the I/O will be a combination of the I/O type's response time and the configurable software filtering, ramps, delays, etc. that were selected in the application.
Reflashing Software over CAN	Reflash software over the CAN bus using the Electronic Assistant®.

Packaging	High Temperature Nylon housing - Deutsch IPD PCB Enclosure (EEC-325X4B) 4.62 x 5.24 x 1.43 inches 117.42 x 133.09 x 36.36 mm (W x L x H excluding mating plugs) Refer to the dimensional drawing.
Protection	IP67 rating for the product assembly
Weight	0.50 lb. (0.23 kg)
Temperature Rating	-40°C to +125°C (-40°F to 257°F)

Electrical Connections	<p>12 pin Deutsch IPD connector P/N: DTM13-12PA-R008 20 AWG wire is recommended for use with contacts 0462-201-20141.</p> <table border="1"> <thead> <tr> <th colspan="2">CAN and I/O Connector</th> </tr> <tr> <th>Pin #</th> <th>Description (Notes)</th> </tr> </thead> <tbody> <tr> <td>1</td> <td>BATT -</td> </tr> <tr> <td>2</td> <td>CAN_L</td> </tr> <tr> <td>3</td> <td>CAN_H</td> </tr> <tr> <td>4</td> <td>P_GND (Out 1 and Out 2)</td> </tr> <tr> <td>5</td> <td>Analog_GND (Input 1 and Input 2)</td> </tr> <tr> <td>6</td> <td>Input 1+</td> </tr> <tr> <td>7</td> <td>Input 2+</td> </tr> <tr> <td>8</td> <td>+5V Ref</td> </tr> <tr> <td>9</td> <td>Output 2+ (Default: Not Used)</td> </tr> <tr> <td>10</td> <td>Output 1+</td> </tr> <tr> <td>11</td> <td>CAN_Shield</td> </tr> <tr> <td>12</td> <td>BATT +</td> </tr> </tbody> </table>	CAN and I/O Connector		Pin #	Description (Notes)	1	BATT -	2	CAN_L	3	CAN_H	4	P_GND (Out 1 and Out 2)	5	Analog_GND (Input 1 and Input 2)	6	Input 1+	7	Input 2+	8	+5V Ref	9	Output 2+ (Default: Not Used)	10	Output 1+	11	CAN_Shield	12	BATT +
CAN and I/O Connector																													
Pin #	Description (Notes)																												
1	BATT -																												
2	CAN_L																												
3	CAN_H																												
4	P_GND (Out 1 and Out 2)																												
5	Analog_GND (Input 1 and Input 2)																												
6	Input 1+																												
7	Input 2+																												
8	+5V Ref																												
9	Output 2+ (Default: Not Used)																												
10	Output 1+																												
11	CAN_Shield																												
12	BATT +																												
Mating Plug Kit	Axiomatic P/N: <b>PL-DTM06-12SA</b> . It is comprised of the following Deutsch IPD parts: plug (DTM06-12SA); wedgelock (WM12S); and 12 contacts (0462-201-20141) as well as 6 sealing plugs (0413-204-2005).																												
Installation	Mounting holes sized for ¼ inch or M6 bolts. The bolt length will be determined by the end-user's mounting plate thickness. The mounting flange of the controller is 0.63 inches (16 mm) thick. All field wiring should be suitable for the operating temperature range, rated voltage and current. Wiring to the product must be in accordance with all applicable local codes. Install the unit with appropriate space available for servicing and for adequate wire harness access (6 inches or 15 cm) and strain relief (12 inches or 30 cm).																												
Network Termination	It is necessary to terminate the network with external termination resistors. The resistors are 120 Ohm, 0.25W minimum, metal film or similar type. They should be placed between CAN_H and CAN_L terminals at both ends of the network.																												

Note: CANopen® is a registered community trade mark of CAN in Automation e.V.  
Electronic Assistant® is a registered U.S. trade mark of Axiomatic Technologies Corporation.  
Simulink® is a registered trademark of The Mathworks, Inc.

*Specifications are indicative and subject to change. Actual performance will vary depending on the application and operating conditions. Users should satisfy themselves that the product is suitable for use in the intended application. All our products carry a limited warranty against defects in material and workmanship. Please refer to our Warranty, Application Approvals/Limitations and Return Materials Process as described on [www.axiomatic.com/service.html](http://www.axiomatic.com/service.html).*

Form: TDAX023220-06/30/15