

Distributed I/O for Engine Control Systems

Features:

- 4 independent analog signal outputs (voltage or current)
- User selectable output range from +/-10V or +/-20 mA, including: 0-5V; 0-10V; +/-5V; +/-10V; 0-20mA; 4-20 mA; and +/-20mA.
- 12V/24V/48VDC input power (nominal) with rugged surge protection
- Galvanic isolation between power supply and analog signal outputs
- 1 CAN (SAE J1939), CANopen® on request
- Rugged IP67 packaging and connectors
- Vibration compliant for engine applications
- **Electronic Assistant®** runs on a *Windows* operating system for user configuration and programming. An Axiomatic USB-CAN converter links the PC to the CAN bus.



Applications:

- Distributed controls for power generation, co-generation, stationary power
- Distributed controls for commercial vehicles, off-highway equipment, industrial equipment, etc.

Ordering Part Numbers:

SAE J1939 Controller: For baud rate, refer to the table below for the appropriate P/N.

Model P/N	Baud Rate	Standard Reference
AX030500	250 kBit/s	J1939/11, J1939/15.
AX030502	500 kBit/s	J1939/14. New standard
AX030503	1Mbit/s	Non-standard

Accessories:

PL-DTM06-12SA Mating Plug Kit (1 DTM06-12S, 1 WM12S, 12 contacts, FG- IOCTRL-20)

Electronic Assistant® Configuration KIT: **AX070502**

Block Diagram

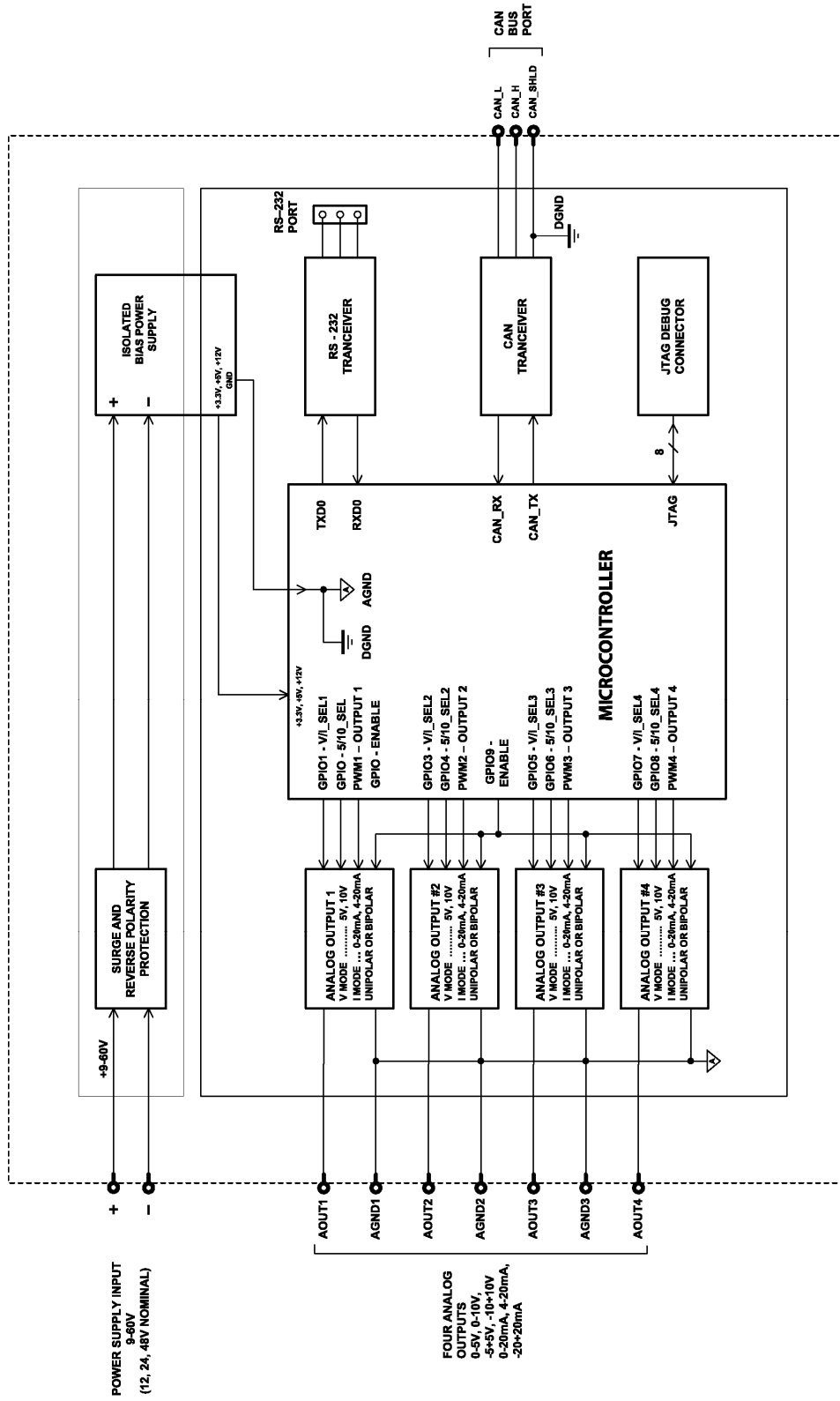

**Technical Specifications:
Input Specifications**

Power Supply Input - Nominal	12V, 24V or 48VDC nominal (9...60 VDC power supply range)
Protection	Surge and reverse polarity protection are provided.
Isolation	A transformer power supply provides galvanic isolation between the power supply input and the analog signal outputs.
Input	CAN Messages, SAE J1939 {CANopen® (model AX030501) available on request} The CAN signal can be filtered to accept messages from a single address on the network permitting a link to a specific ECU. The Electronic Assistant® (EA) is used to set up CAN signal acquisition and processing algorithms.

Output Specifications

CAN	The controller can send a single frame application specific CAN message to the network continuously or on request. Using the EA, the user can configure this feature.
Analog Outputs	Up to 4 analog signal outputs are selectable by the user. Refer to Table 1.0.
Ground Connection	3 Analog GND connections are provided. They are connected together internally.
Protection for Output + Terminal	Fully protected against short circuit to ground and short circuit to power supply rail. Unit will fail safe in the case of a short circuit condition, self-recovering when the short is removed.

Table 1.0 - Outputs	
Analog Outputs	Up to 4 analog signal outputs are available. Using the Electronic Assistant®, the user selects: <ul style="list-style-type: none"> the output mode (voltage or current); and the minimum and maximum values for the output signal from the +/-10V or +/-20 mA range. Standard analog signal ranges are supported, including: 0-5V; 0-10V; +/-5V; +/-10V; 0-20mA; 4-20 mA; and +/-20mA. The outputs can be globally enabled or disabled.
Output Accuracy	0.5%
Output Resolution	0.015% (>12 bit)

Control Logic

From the software perspective, the controller consists of a set of internal functional blocks, which can be individually programmed and arbitrarily connected together to achieve the required system functionality, see Figure 1.

Each functional block is absolutely independent and has its own set of programmable parameters, or setpoints. The setpoints can be viewed and changed through CAN using the Electronic Assistant®.

There are two types of the controller functional blocks. One type represents the controller hardware resources, for example the analog signal output block. The other type is purely logical – these functional blocks are included to program the user defined functionality of the controller. The number and functional diversity of these functional blocks are only limited by the system resources of the internal microcontroller. They can be added or modified on the customer’s request to accommodate user-specific requirements.

The user can build virtually any type of a custom control by logically connecting inputs and outputs of the functional blocks. This approach gives the user an absolute freedom of customization and an ability to fully utilize the controller hardware resources in a user’s application.

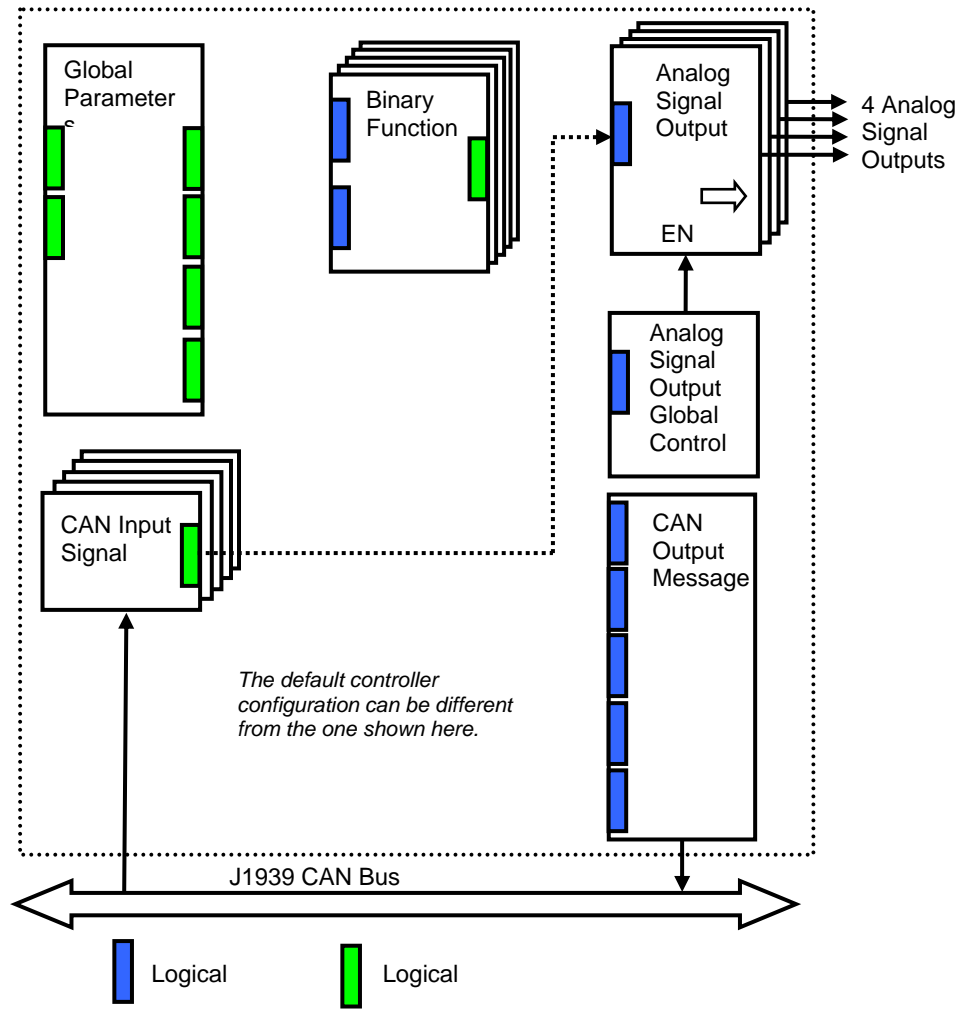

As an example, the logical output of the CAN Input Signal functional block is connected to the logical input of the Analog Signal Output functional block, providing a direct path for the CAN input signal to the controller signal output.

Figure 1.The Controller Internal Structure.

Depending on the block functionality, a functional block can have: logical inputs, logical outputs or any combinations of them. The connection between logical inputs and outputs is defined by logical input setpoints. The following rules apply:

- A logical input can be connected to any logical output using a logical input setpoint.
- Two or more logical inputs can be connected to one logical output.
- Logical outputs do not have their own setpoints controlling their connectivity. They can only be chosen as signal sources by logical inputs.

Each functional block of the controller is presented by its own folder in the Setpoint File root folder in the Electronic Assistant®.

General Specifications

Microprocessor	STM32, 32-bit, 128 KByte flash program memory												
Control Logic	Standard embedded software is provided. Refer to Figure 1.0. (Application-specific control logic or factory programmed setpoints are available on request.)												
Monitoring and Troubleshooting	The controller can also transmit a CAN application message carrying signals internally generated by the controller. This feature can be used for monitoring and debugging purposes.												
CAN	<p>1 CAN port (SAE J1939) (Model AX030501 is CANopen®)</p> <p>For baud rate, refer to the table below.</p> <table border="1"> <thead> <tr> <th>Model P/N</th> <th>Baud Rate</th> <th>Standard Reference</th> </tr> </thead> <tbody> <tr> <td>AX030500</td> <td>250 kBit/s</td> <td>J1939/11, J1939/15.</td> </tr> <tr> <td>AX030502</td> <td>500 kBit/s</td> <td>J1939/14. New standard</td> </tr> <tr> <td>AX030503</td> <td>1Mbit/s</td> <td>Non-standard</td> </tr> </tbody> </table>	Model P/N	Baud Rate	Standard Reference	AX030500	250 kBit/s	J1939/11, J1939/15.	AX030502	500 kBit/s	J1939/14. New standard	AX030503	1Mbit/s	Non-standard
Model P/N	Baud Rate	Standard Reference											
AX030500	250 kBit/s	J1939/11, J1939/15.											
AX030502	500 kBit/s	J1939/14. New standard											
AX030503	1Mbit/s	Non-standard											
User Interface (PC-based)	<p>The controller setpoints can be viewed and programmed using the standard J1939 memory access protocol through the CAN port and the PC-based Axiomatic Electronic Assistant®.</p> <p>The Electronic Assistant® for <i>Windows</i> operating systems comes with a royalty-free license for use on multiple computers.</p> <p>It requires an USB-CAN converter to link the device's CAN port to a <i>Windows</i>-based PC. An Axiomatic USB-CAN Converter AX070501 is available as part of the Axiomatic Configuration KIT.</p> <p>P/N: AX070502, the Axiomatic Configuration KIT includes the following. USB-CAN Converter P/N: AX070501 1 ft. (0.3 m) USB Cable P/N: CBL-USB-AB-MM-1.5 12 in. (30 cm) CAN Cable with female DB-9 P/N: CAB-AX070501 AX070502IN CD P/N: CD-AX070502, includes: Electronic Assistant® software; EA & USB-CAN User Manual UMAX07050X; USB-CAN drivers & documentation; CAN Assistant (Scope and Visual) software & documentation; and the SDK Software Development Kit.</p>												
Quiescent Current Draw	<p>< 340 mA @ 12V and full load < 160 mA @ 24V and full load < 90 mA @ 48V and full load</p>												
Response Time	10 mSec. max.												
Weight	0.50 lb. (0.23 kg)												
Operating Conditions	-40 to 85 °C (-40 to 185 °F)												
Storage Temperature	-55 to 125 °C (-67 to 257°F)												
Vibration and Shock Compliance	<p>MIL-STD-202G, Test 204D, 214A and 213B 7.68 Grms (Random) 10 g peak (Sine) 50 g (Shock)</p>												
Protection	IP67, PCB is conformal coated and protected by the housing.												
Packaging and Dimensions	<p>High Temperature Nylon housing - Deutsch IPD PCB Enclosure (EEC-325X4B) 4.62 x 5.24 x 1.43 inches 117.42 x 133.09 x 36.36 mm (W x L x H excluding mating plugs) Refer to the dimensional drawing.</p>												
Mounting	<p>Mounting holes sized for ¼ inch or M6 bolts. The bolt length will be determined by the end-user's mounting plate thickness. The mounting flange of the controller is 0.63 inches (16 mm) thick.</p> <p>If the module is mounted without an enclosure, it should be mounted vertically with connectors facing left and right to reduce likelihood of moisture entry.</p> <p>The CAN wiring is considered intrinsically safe. The power wires are not considered intrinsically safe and so in hazardous locations, they need to be located in conduit or conduit trays at all times. The module must be mounted in an enclosure in hazardous locations for this purpose.</p> <p>No wire or cable harness should exceed 30 meters in length. The power input wiring should be limited to 10 meters.</p> <p>All field wiring should be suitable for the operating temperature range.</p> <p>Install the unit with appropriate space available for servicing and for adequate wire harness access (6 inches or 15 cm) and strain relief (12 inches or 30 cm).</p>												
Network Termination	It is necessary to terminate the network with external termination resistors. The resistors are 120 Ohm, 0.25W minimum, metal film or similar type. They should be placed between CAN_H and CAN_L terminals at both ends of the network.												

HOUSING DIMENSIONS

Housing Material: High Temperature Nylon (Black)
Protection Rating: IP67

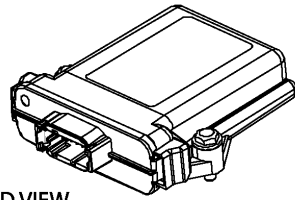

3D VIEW
12 Pin Receptacle

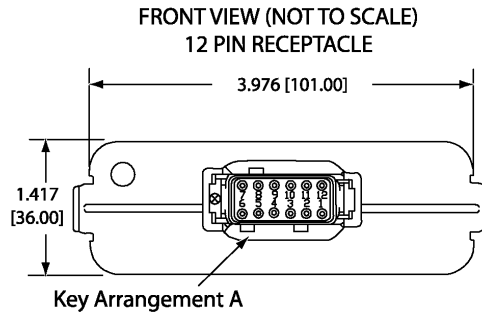
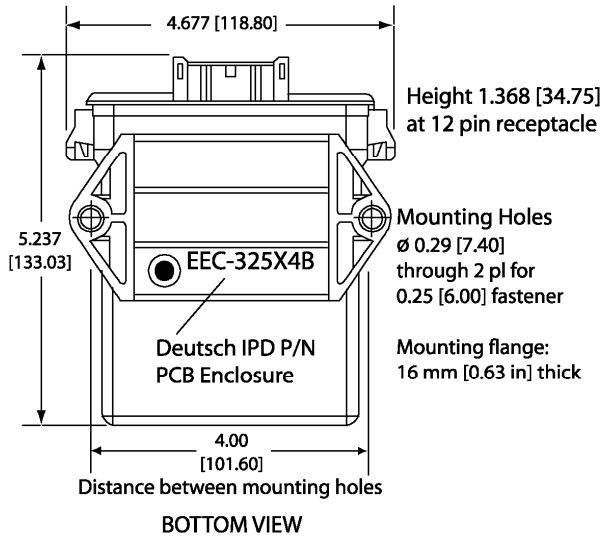

Mating Plug Assemblies:
12 pin receptacle - DTM06-12SA with wedgelock WM12S and contacts
24 pin receptacle - DTM06-12SA and DTM06-12SB with wedgelocks WM12S and contacts
Contact factory for contact specification.

Dimensions: inches [mm] excluding mating plug(s)

Electrical Connections

Deutsch DTM series 12 pin receptacle (P/N: DTM13-12PA-R008)

20 AWG wire is recommended for use with contacts 0462-201-20141.

PIN #	FUNCTION
1	Analog GND
12	Analog GND
2	Output 1+
11	CAN_L
3	Output 2+
10	CAN_H
4	Output 3+
9	CAN_Shield
5	Output 4+
8	Power -
6	Analog GND
7	Power +

Mating plug KIT: Available from Axiomatic as p/n: **PL-DTM06-12SA**. It is comprised of the following Deutsch IPD parts: plug (DTM06-12SA); wedgelock (WM12S); and 12 contacts (0462-201-20141) as well as 6 sealing plugs (0413-204-2005). *If not all of the outputs are required for the application, use the sealing plugs to fill the mating connector pins.*

Wiring to these mating plugs must be in accordance with all applicable local codes. Suitable field wiring for the rated voltage and current must be used. The rating of the connecting cables must be at least 70°C. Use field wiring suitable for both minimum and maximum ambient temperature.

Note: CANopen® is a registered community trade mark of CAN in Automation e.V.
Electronic Assistant® is a registered trademark of Axiomatic Technologies Corporation.

Specifications are indicative and subject to change. Actual performance will vary depending on the application and operating conditions. Users should satisfy themselves that the product is suitable for use in the intended application. All our products carry a limited warranty against defects in material and workmanship. Please refer to our Warranty, Application Approvals/Limitations and Return Materials Process as described on www.axiomatic.com/service.html.

Form: TDAX030500-07/03/15