

Inclinometer

CAN (SAE J1939) or (CANopen®)

with Electronic Assistant® 

P/N: AX06020X

Features:

- 1 or 2 axis inclination or slope sensors
- 2 axis (-80°...80°), functional up to $\pm 90^\circ$
- 1 axis, vertically positioned (-180° ... 180° or 0...360°)
- High resolution and accuracy
- Option: Three 0-5VDC outputs for direct connection to an analog monitoring control
- CAN (SAE J1939) port (Option: RS232 output)
- CANopen® models available
- 12V, 24VDC nominal
- Aluminum enclosure with 2 integral M12 5-pin connectors, IP67 (Option: D version for underwater)
- Configurable using the **Electronic Assistant®** 
- *Proprietary PGN's can be programmed using the Electronic Assistant®.*
- *Alternate applications can be accommodated with programming using the EA. For example, in a tilt sensor application an out-of-range state can be transmitted as one of its outputs.*



Applications:

- Industrial Automation, Cranes, Hoists, Utility Vehicles, Off-highway, Ag, and Forestry Equipment

Ordering Part Numbers:

Inclinometers:

AX060201 (D) – Inclinometer, CAN (SAE J1939), 2 axis (-80°...80°)

– Inclinometer, CAN (SAE J1939), 1 axis* (-180° ... 180° or 0...360°)

* For all single axis functionality, use the Electronic Assistant® to configure the inclinometer prior to installation.

AX060202 (D) – Inclinometer, CAN (SAE J1939), 3 Analog Outputs (X, Y, Vertical Mount),

2 axis (-80°...80°), 1 axis if vertically mounted (-180° ... 180° or 0...360°**)

** For 0...360° single axis functionality, use the Electronic Assistant® to configure the inclinometer prior to installation.

AX060203 (D) – Inclinometer, CAN (SAE J1939), 1 RS-232,

2 axis (-80°...80°), 1 axis if vertically mounted (-180° ... 180° or 0...360°**)

** For 0...360° single axis functionality, use the Electronic Assistant® to configure the inclinometer prior to installation.

AX060250 (D) – Inclinometer, CANopen® (Refer to TDAX06025X.)

AX060251 (D) – Inclinometer, CANopen®, 3 Analog Outputs

AX060252 (D) – Inclinometer, CANopen®, 1 RS-232

Note: (D) refers to a version for underwater applications. Please add D to the p/n to order this version.

Accessories:

AX070114 - A mating plug with CAN termination, P/N: AX070114, can be ordered to plug the 2nd connector for applications requiring only one CAN and Power connection as well as requiring a termination of the CAN network.

Mating cables are not supplied.

Electronic Assistant® over CAN (SAE J1939 only): P/N: AX070502

Description: The inclinometer is designed to accurately measure inclination angles in two directions X and Y in the range of $\pm 80^\circ$. It is functional up to $\pm 90^\circ$. If vertically installed, it can measure an inclination angle in one sensing direction in the $\pm 180^\circ$ (0-360°) range.

The angles are measured by a two-axis MEMS sensor, which senses acceleration caused by the gravity force in two orthogonal directions. The output signals from the MEMS sensor are normalized and processed by a microcontroller. The resolved angles can be then sent to the SAE J1939 or CANopen® fieldbus, RS232 port or output as voltages using three available inclinometer signal voltage outputs.

Due to a powerful microcontroller, the inclinometer can perform pre-processing of the angular information according to the users' needs. Its internal architecture is user-programmable and allows users to define their own custom functionality using a set of predefined internal functional blocks. All application programming is performed through SAE J1939 CAN interface by the PC-based Axiomatic Electronic Assistant® software.

The standard inclinometer is IP67 rated and is packaged in a cast Aluminum housing with 2 M12 5-pin connectors. Contact Axiomatic with application-specific connection requirements.

Dual Axis Functionality

There are two identical functional blocks: Sensor X and Sensor Y presenting angular data from two orthogonal sensing directions X and Y of the inclinometer sensor.

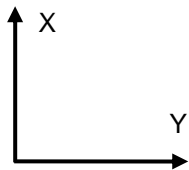

Figure 1.0 Sensing Direction Vectors

The inclinometer measures angles between the sensing directions and the ground plane. Normally, the sensor is mounted horizontally, with the sensing direction vectors being in parallel with the ground plane.

When a sensing direction vector points up, out of the ground plane, the inclination angle is considered to be positive, and when the sensing direction vector points down, into the ground plane, it is negative.

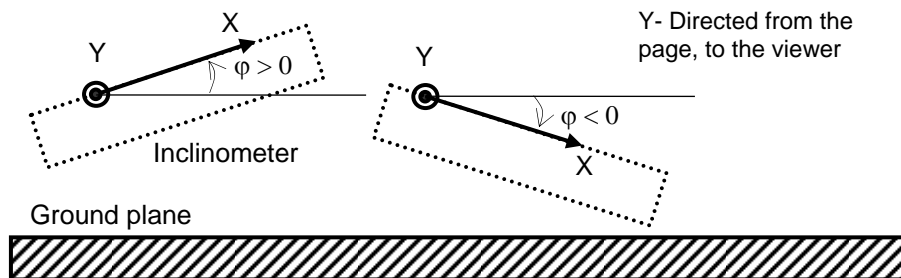

Figure 2: Dual Axis Functionality with the Inclinometer mounted horizontally – Sensor X and Sensor Y Functional Blocks

Model AX060201: By default, the CAN output message functional blocks are programmed to send PGN 61459, PGN 65256 and PGN 64905 CAN output messages conveying the pitch and roll vehicle inclination angles. To comply with the PGN requirements, the sensing direction X of the sensor should point to the travel direction of the vehicle. It will sense the pitch angle. The sensing direction Y, in this case, will point to the right hand side of the vehicle from the driver's seat (facing the direction of travel) and sense the angle opposite to the roll angle. The signal from the Y sensing direction is inverted in the CAN output message functional block to represent the roll angle of the vehicle.

CAN output message functional blocks are deactivated by default in **models AX060202 and AX060203**. They can be activated and/or reprogrammed by using the Electronic Assistant® to send pitch and roll angles or other user-defined information.

Single Axis Functionality

The single axis functionality is provided by the vertically mounted sensor functional block. It is available only when the inclinometer is mounted vertically, orthogonally to the ground plane. In this position, if kept vertically, the inclinometer can measure an inclination angle in one direction in the whole $\pm 180^\circ$ degree range.

The sensing direction of the vertically mounted sensor is the same as the Y sensing direction of the regularly (horizontally) mounted sensor. When the X sensing direction points up and the Y sensing direction points to the right, and is in parallel with the ground plane, the inclination angle is zero.

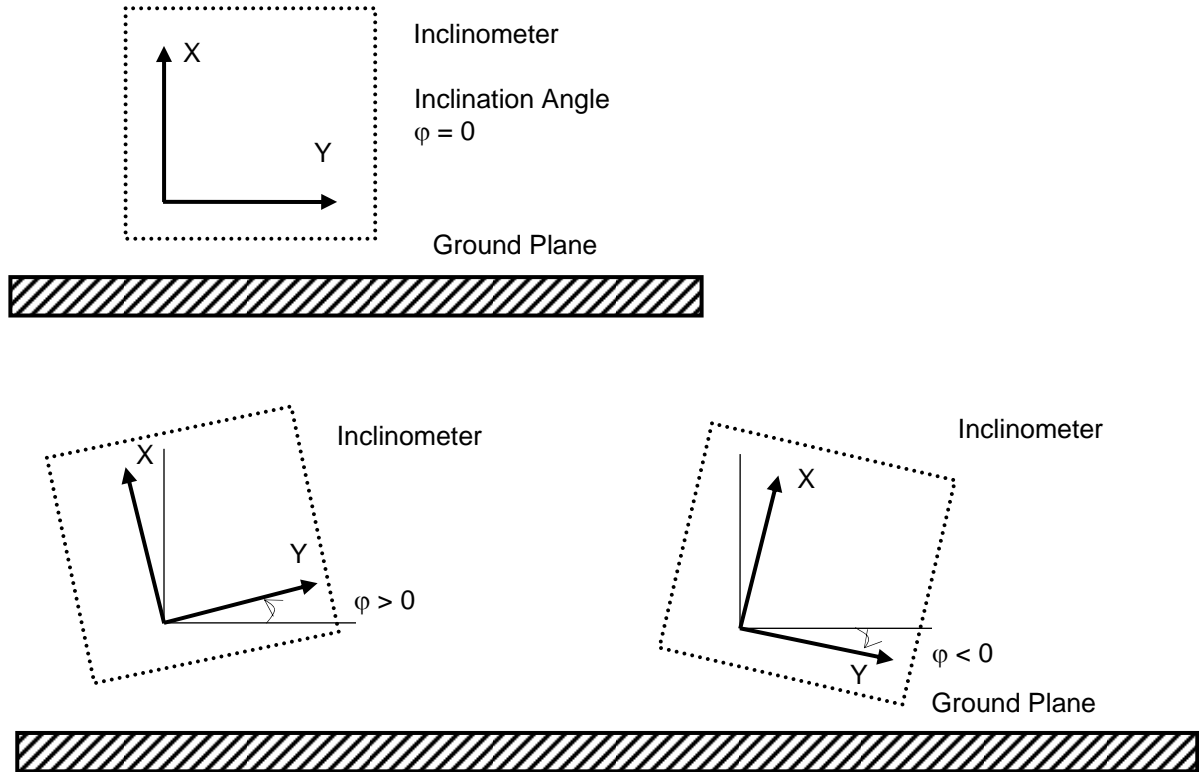
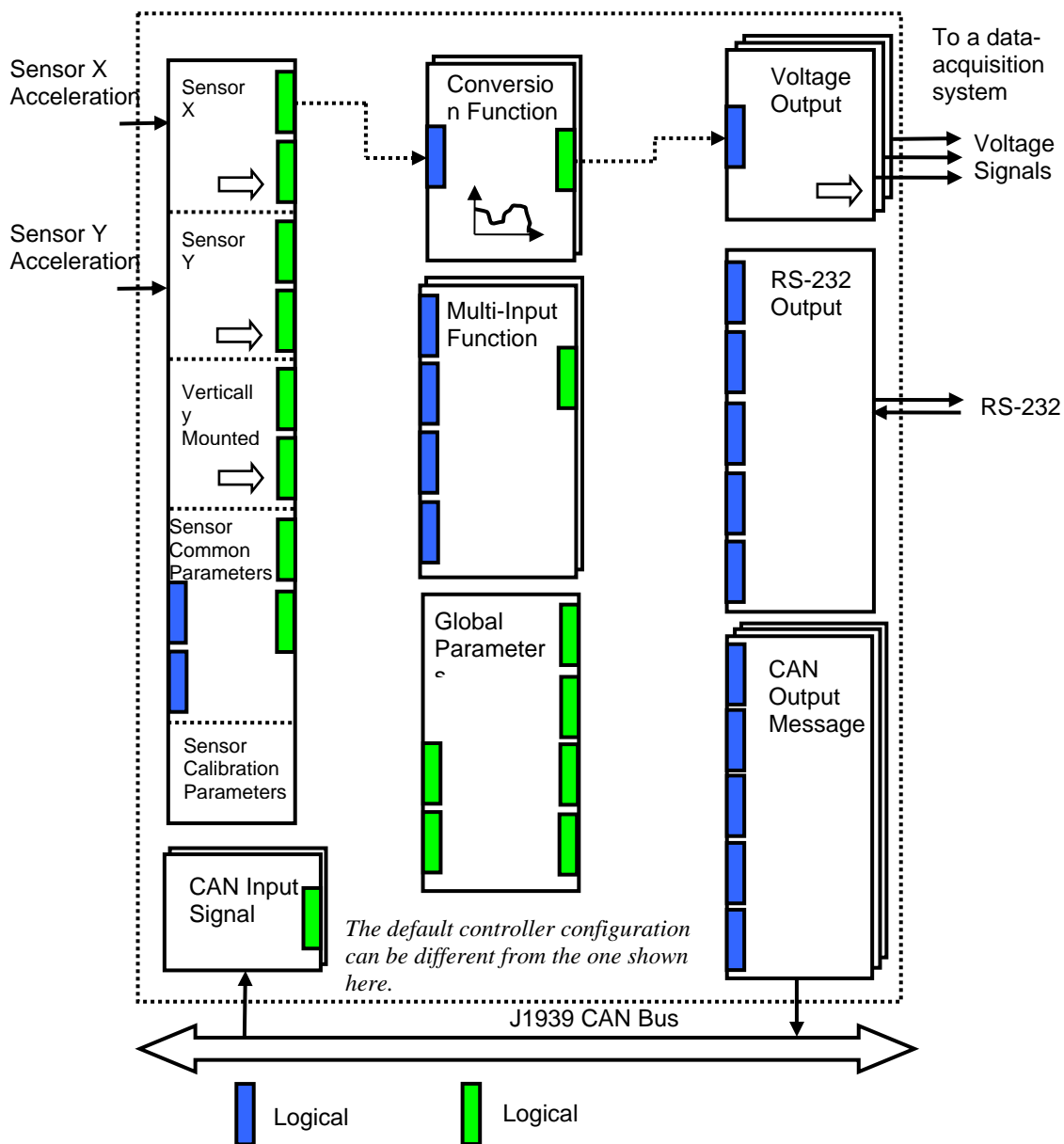

Figure 3: Single Axis Functionality with the Inclinometer mounted vertically – Vertically mounted sensor functional block - The counterclockwise rotation of the sensor produces positive angles and the clockwise, correspondingly, negative.

Other Functions

Using the Electronic Assistant®, the inclinometer can be reprogrammed for another function. Besides using CAN to output angles, the inclinometer can work as a CAN bus reader, presenting CAN input signals as voltages at any of the inclinometer signal voltage outputs. It can also send CAN input signals as text messages using the inclinometer RS-232 port. In a tilt sensor application, an out-of-range state (signal) can be transmitted at one of its voltage outputs.

The inclinometer consists of a set of internal functional blocks, which can be individually programmed and arbitrarily connected together to achieve the required system functionality, see Figure 1.



As an example, the Sensor X output is connected to a Conversion Function and the Conversion Function is connected to a Voltage Signal Output, providing a path for the sensor X angular signal from input to output through a Conversion Function.

Figure 1. Inclinometer Internal Structure

Technical Specifications:

Power Input

Power Supply Input	12V, 24V nominal (9...43 VDC power supply range)
Supply Current	40 mA at 12 V Typical 22 mA at 24 V Typical
Protection	Reverse polarity and transient protection is provided.

Angle Measurements

Operation Modes	Dual Axis or Single Axis
-----------------	--------------------------

Single Axis – Angle Range	Single Axis: -180°...180° (0...360°) NB. Vertical position of the inclinometer should be maintained within the maximum displacement angle ($\pm 20^\circ$, by default)
Resolution	$\pm 0.05^\circ$ Maximum
Initial Accuracy	$\pm 0.25^\circ$ Maximum, at 25°C
Repeatability	$\pm 0.05^\circ$ Maximum
Nonlinearity	$\pm 0.1^\circ$ Typical

Dual Axis – Angle Range	Dual Axis: -80°...80° (Functional up to $\pm 90^\circ$)	
	Low-angle range	High-angle range
Dual Axis Measurement Range	-30°...30°	-80°...-30° 30°...80°
Resolution	$\pm 0.05^\circ$ Maximum	$\pm 0.2^\circ$ Maximum
Initial Accuracy	$\pm 0.25^\circ$ Maximum, at 25°C	$\pm 0.5^\circ$ Maximum, at 25°C
Repeatability	$\pm 0.05^\circ$ Maximum	$\pm 0.2^\circ$ Maximum
Temperature Drift	± 0.0015 %/°C Typical, at 0° over the full temperature range -40...85°C	-
Nonlinearity	$\pm 0.1^\circ$ Typical	$\pm 0.25^\circ$ Typical
Cross-Axis Sensitivity	0.5% Typical	

Outputs

In P/N AX060201: CAN	In P/N AX060201: 1 CAN port SAE J1939 In P/N: AX060201: By default, the inclinometer transmits pitch and roll angles on the CAN network according to SAE J1939/71 requirements for a slope sensor (PGN 61459, PGN 65256 and PGN 64905). In P/N AX060250: CANopen® It conforms to CiA DSP410 device profile for inclinometer. Refer to TDAX06025X.
Protection	Short circuit to ground Connection to the power supply (24V maximum)
Network Termination	According to the SAE J1939 standard, it is necessary to terminate the network with external termination resistors. The resistors are 120 Ohm, 0.25W minimum, metal film or similar type. They should be placed between CAN_H and CAN_L terminals at both ends of the network. (Resistor is not provided.)

In P/N AX060203: RS-232	In P/N AX060203: 1 RS-232 Text Format 115200 Baud Rate Data – 8 bit, Parity – None, Stop – 1 bit. Flow Control – No. Short circuit protection to ground.
----------------------------	--

In P/N: AX060202: Output Voltages	In P/N AX060202: 3 Analog (0-5V)	
	Voltage Output 1: Sensor X Angle (default)	Dual-axis mode -90° → 0 V (default, user configurable) 90° → 5 V (default, user configurable)
	Voltage Output 2: Sensor Y Angle (default)	
	Voltage Output 3: Vertical Mount Sensor Angle (default)	Axis direction is the same as the Y-axis in the dual-axis mode -180° → 0 V (default, user configurable) 180° → 5 V (default, user configurable)
Maximum Output Current	5mA per channel	
Resolution	≤ 0.015%	
Initial Accuracy	≤ 0.15% @25°C	
Temperature Drift	≤ 30 ppm/ °C over the full temperature range -40...85°C	
Protection	Overcurrent (short circuit) Current is limited at ≈11.5mA	
	Connection to the power supply.	
	Connection to a reverse polarity voltage source (24V maximum)	

General Specifications

Cut-off frequency, Fc	5 Hz (default) 1...20 Hz (User configurable)
Settling Time	0.3 sec. Typical at Fc ≥ 5Hz from 0 to 95% of the static output value
Microprocessor	32-bit, 128 Kbyte flash program memory
Sensor	Dual axis MEMS acceleration sensor
Control Logic	User programmable functionality using Electronic Assistant® Refer to UMAX06020X-40X for details.
User Interface	Electronic Assistant® for <i>Windows</i> operating systems P/N: AX070502 It comes with a royalty-free license for use on multiple computers. The Electronic Assistant® includes an USB-CAN converter to link the device's CAN port to a <i>Windows</i> -based PC.
Operating Conditions	-40 to 85 °C (-40 to 185 °F)
Packaging and Connectors	Cast Aluminum enclosure 2 Round M12 5-pin A-coded integral connector(s) CONEC P/N: 43-02079 (M12 FEMALE) CONEC P/N: CONEC 43-02080 (M12 MALE) Encapsulated, Lid Gasket Dimensions: 2.90 x 5.35 x 1.42 inches 73.66 x 135.99 x 36.16 mm (L x W x H)
Protection	IP65 (IP67 on request for underwater applications)
Weight	0.85 lbs, 0.39 kg
Vibration	MIL-STD-202G, Test 204D and 214A (Sine and Random) 10 g peak (Sine) 7.86 Grms peak (Random)
Shock	MIL-STD-202G, Test 213B 50g
Approvals	CE marking

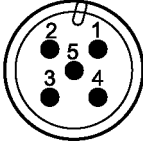
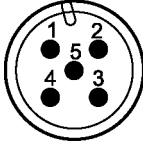
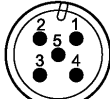
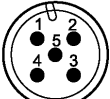
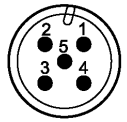
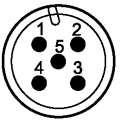
<p>Electrical Connections Model AX060201</p>	<p>P/N: AX060201 (CAN SAE J1939)</p> <p>INPUT CONNECTOR OUTPUT CONNECTOR</p> <div style="display: flex; justify-content: space-around; align-items: center;"> <div style="text-align: center;">  <p>M12 Male FRONT VIEW</p> </div> <div style="text-align: center;">  <p>M12 female FRONT VIEW</p> </div> </div> <div style="display: flex; justify-content: space-around; margin-top: 10px;"> <div style="width: 45%;"> <ol style="list-style-type: none"> 1. CAN SHIELD 2. Power + 3. Power - 4. CAN HI 5. CAN LO </div> <div style="width: 45%;"> <ol style="list-style-type: none"> 1. CAN SHIELD 2. Power + 3. Power - 4. CAN HI 5. CAN LO </div> </div> <p style="font-size: small; margin-top: 10px;">A mating plug with CAN termination, P/N: AX070114, can be ordered to plug the 2nd connector for applications requiring only one CAN and Power connection as well as requiring a termination of the CAN network.</p>
<p>Electrical Connections Model AX060202</p>	<p>P/N: AX060202 (3 Analog Outputs)</p> <p>INPUT CONNECTOR OUTPUT CONNECTOR</p> <div style="display: flex; justify-content: space-around; align-items: center;"> <div style="text-align: center;">  <p>M12 Male FRONT VIEW</p> </div> <div style="text-align: center;">  <p>M12 female FRONT VIEW</p> </div> </div> <div style="display: flex; justify-content: space-around; margin-top: 10px;"> <div style="width: 45%;"> <ol style="list-style-type: none"> 1. CAN SHIELD 2. Power + 3. Power - 4. CAN HI 5. CAN LO </div> <div style="width: 45%;"> <ol style="list-style-type: none"> 1. Voltage Output 1 (0-5V, Sensor X Angle Default) 2. Voltage Output 2 (0-5V, Sensor Y Angle Default) 3. Voltage Output 3 (0-5V, Vertical Mount Sensor Angle Default) 4. NOT USED 5. ANALOG GND </div> </div> <p style="font-size: small; margin-top: 10px;">Default settings are configurable with the Electronic Assistant®.</p>
<p>Electrical Connections Model AX060203</p>	<p>P/N: AX060203 (RS-232)</p> <p>INPUT CONNECTOR OUTPUT CONNECTOR</p> <div style="display: flex; justify-content: space-around; align-items: center;"> <div style="text-align: center;">  <p>M12 Male FRONT VIEW</p> </div> <div style="text-align: center;">  <p>M12 female FRONT VIEW</p> </div> </div> <div style="display: flex; justify-content: space-around; margin-top: 10px;"> <div style="width: 45%;"> <ol style="list-style-type: none"> 1. CAN SHIELD 2. Power + 3. Power - 4. CAN HI 5. CAN LO </div> <div style="width: 45%;"> <ol style="list-style-type: none"> 1. NOT USED 2. RS-232 TXD 3. RS-232 RXD 4. NOT USED 5. RS-232 GND </div> </div>
<p>Installation</p>	<p>Mounting holes accept #10 or M5 screws. The thickness of the mounting flange is 0.13 inch or 3.18 mm.</p> <p>The CAN wiring is considered intrinsically safe. All field wiring should be suitable for the operating temperature range of the module.</p> <p>All chassis grounding should go to a single ground point designated for the machine and all related equipment.</p>

Note: CANopen® is a registered community trade mark of CAN in Automation e.V.

Dimensional Drawing

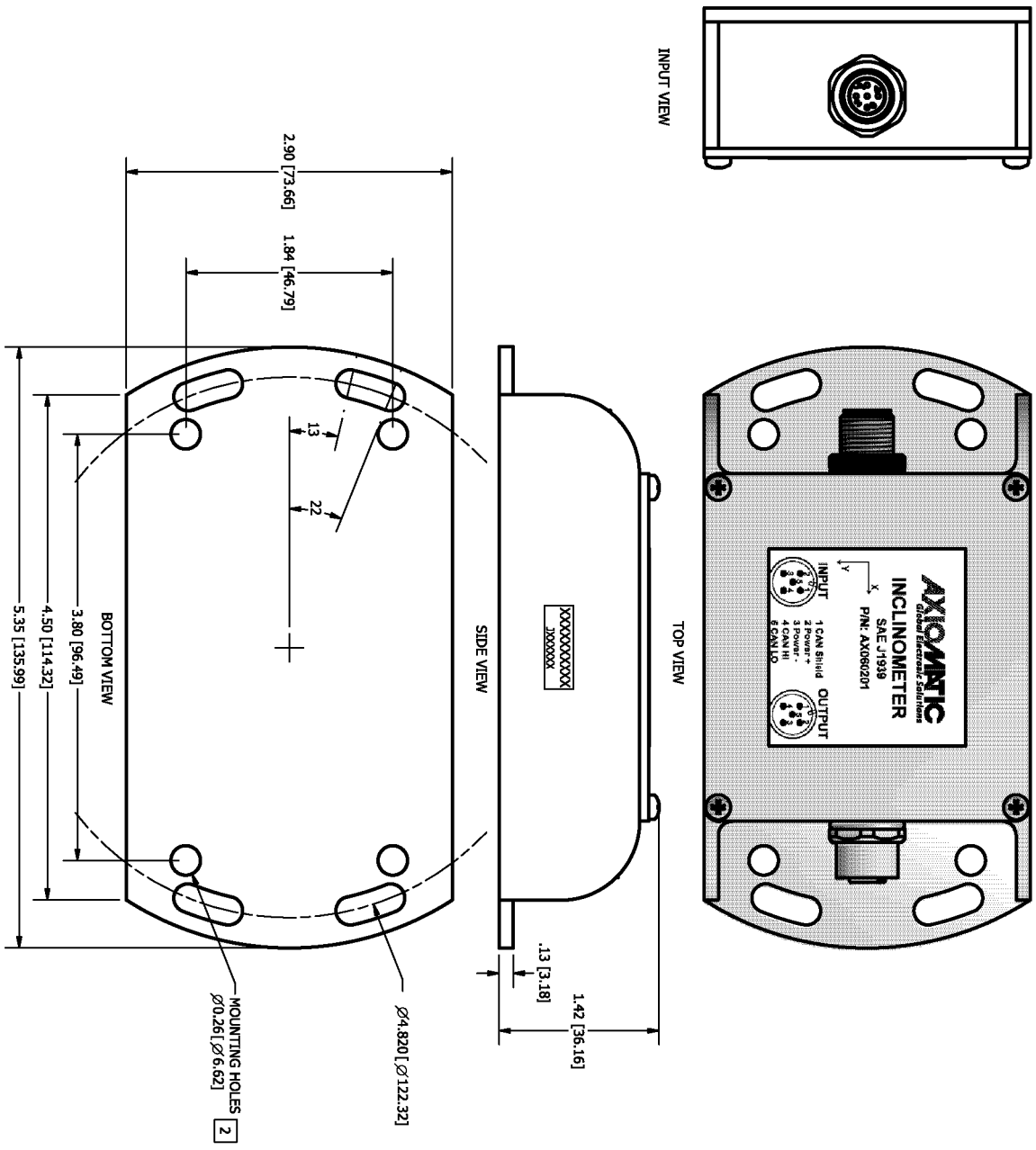

NOTES

- 1 DIMENSIONS ARE IN INCHES [MILLIMETRES].
- 2 MOUNTING HOLES TO SUIT #10 OR M5 HARDWARE.

Specifications are indicative and subject to change. Actual performance will vary depending on the application and operating conditions. Users should satisfy themselves that the product is suitable for use in the intended application. All our products carry a limited warranty against defects in material and workmanship. Please refer to our Warranty, Application Approvals/Limitations and Return Materials Process as described on www.axiomatic.com/service.html.

Form: TDAX06020X-08/21/15