

TECHNICAL DATASHEET #TDAX100280
BLDC MOTOR CONTROLLER
P/N: AX100280

*48V power input
 Variable Speed Control, Onboard Inputs
 480W Nominal Output
 CAN SAE J1939 (or CANopen®), Rugged Packaging
 High Temperature Operation
 with Electronic Assistant*

Features:

- Unidirectional or bi-directional BLDC motor control
- Up to 480W nominal continuous output power to the motor
- Hall effect sensor feedback or sensorless operation
- Flexible control with user selectable modes:
 - Open Loop Speed;
 - Closed Loop Speed;
 - Current control;
 - Position control;
 - or PID control.
- Four (4) Universal inputs are user configurable as Voltage, Current, Resistive, PWM, Frequency, or Digital types.
- The control input to drive the motor can be mapped to any of the universal inputs or the controller can respond to messages from a CAN bus.
- User configurable enable function can be mapped to any of the inputs or a CAN message
- Ignition Switch input turns power ON to unit.
- Direction control can be mapped to any of the inputs or a CAN message
- Output can be coded as feedback messages sent to the CAN bus
- 1 reference voltage (5V, 200 mA max.) are provided to power an external sensor or potentiometer
- Highly efficient and robust design
- Operational from 9 - 65Vdc (12 or 24V or 48Vdc nominal)
- 1 CAN port (SAE J1939) are provided (Model AX100281 for CANopen®)
- Auto baud rate detect functionality for SAE J1939 networks
- **Electronic Assistant** runs on a *Windows* operating system for simple user configuration. An Axiomatic USB-CAN converter links the PC to the CAN bus.
- Compact size for easy mounting
- Suitable for moist, high shock and vibration environments
- Fully sealed with a rugged IP67 enclosure
- Operational up to 125°C temperature



Applications: Motor variable speed, position and/or flow control in Lift Equipment, Electric Vehicles for Material Handling, Trucks, Cranes and Hoists, Hydraulic Tail Lifts and Winches, Golf Carts, Military Equipment, Mobile Pumps and Hydraulic Powerpacks

Ordering Part Numbers:

BLDC Motor Controller, SAE J1939 with auto baud rate detect P/N: **AX100280**

BLDC Motor Controller, CANopen® P/N: **AX100281**

Configuration Tool for SAE J1939 model: Electronic Assistant P/N: **AX070502**

Accessories: Mating Plugs Kit P/N: PL-DTM06-12SA-12SB

Description: The BLDC Motor Controller has four universal inputs that can be configured to measure voltage, current, frequency, PWM duty cycle, resistance or digital voltage level (on/off). It accepts 12Vdc, 24Vdc or 48Vdc nominal input power. The controller can drive brushless DC motors equipped with Hall sensors up to 240W nominal. Sensorless motor control using Back-EMF rotor position detection is also supported. Refer to Figure 1.0.

Measured input data can be sent to a SAE J1939 CAN Network as is or used in the BLDC controller function blocks for controlling how the BLDC motor is driven. The configurable properties of the controller are divided into function blocks, namely, the Input Function Block, the Control Logic Block, the Diagnostic Function Block, the CAN Transmit Message Function Block and the CAN Receive Message Function Block.

A Windows-based Axiomatic Electronic Assistant (EA) is used to configure the controller via the USB-CAN device. There are multiple setpoints accessible with the EA that allow the user to configure the controller to drive a variety of different BLDC motors.

A rugged enclosure, IP67 rating and high temperature operation up to 125°C ensure that the controller is suitable for mounting in harsh equipment environments.

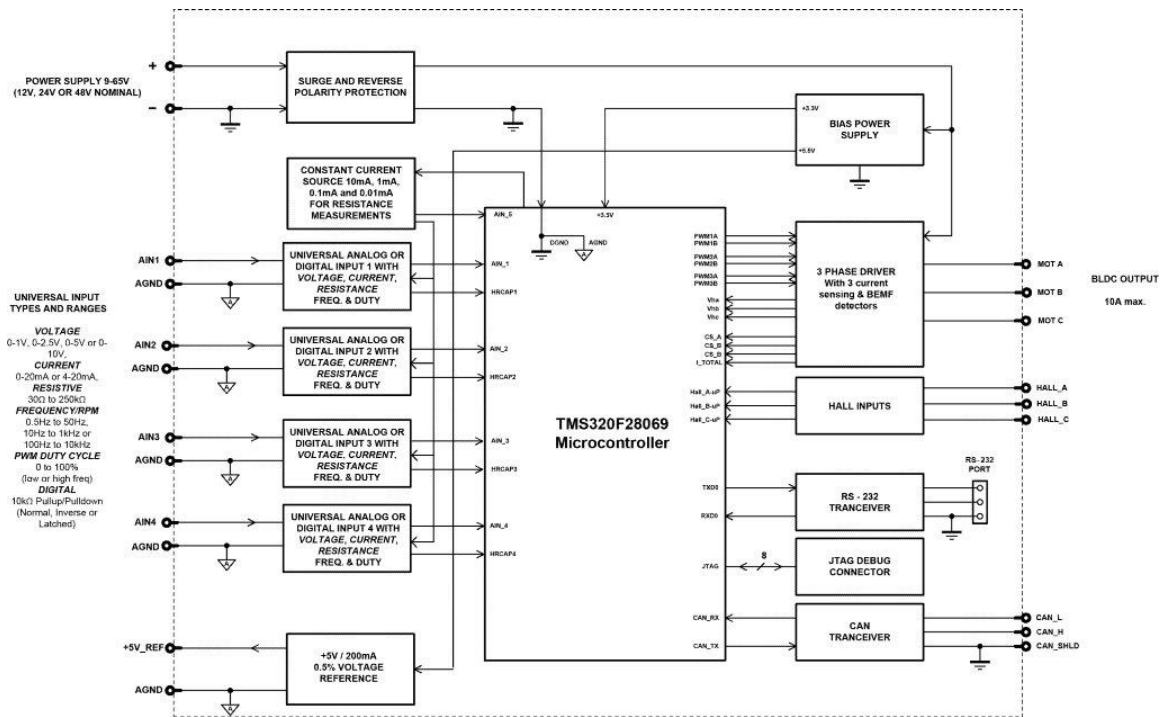

Technical Specifications:

All specifications are typical at nominal input voltage and 25 degrees C unless otherwise specified. Specifications are indicative and subject to change. Actual performance will vary depending on the application and operating conditions. Users should satisfy themselves that the product is suitable for use in the intended application. All our products carry a limited warranty against defects in material and workmanship. Please refer to our Warranty, Application Approvals/Limitations and Return Materials Process as described on www.axiomatic.com/service.html.

Input Specifications

Power Supply Input - Nominal	12, 24 or 48Vdc nominal (9...65Vdc)
Reverse Polarity Protection	Provided up to -100Vdc
Surge Protection	Provided
Under-voltage Protection	Built-in
Signal Inputs	<p>Four (4) universal inputs are user selectable as: Voltage; Current; Resistive; PWM; Frequency; or Digital types.</p> <p>12-bit Analog to Digital resolution Protected against short to ground Amplitude: up to +Vsupply</p> <p>Input properties are user configurable. Refer to the block diagram and Table 1.0. Any input on the controller can be coded into a Proprietary B message that can be sent to the CAN network.</p>
Analog/Digital Ground	One (1) is provided.
Ignition Switch Input	The ignition key input turns the unit power ON. Minimum 2.5V, maximum +Vps
Motor Feedback	<p>Hall Effect Sensor Standard open collector/drain hall input type +5V supply and ground connection pins are provided. 1K Pullup to +5V per input</p> <p>Sensorless operation is also available.</p>

Table 1.0 Inputs (Up to 4 user selectable inputs)	
Inputs	Description
Universal Signal Inputs 1-4	<p>Up to 4 universal signal inputs are available.</p> <p>Voltage Input Types: 0...5VDC or 0...10VDC 1mV resolution, accuracy +/- 1% error The offset is in millivolts and the resolution is mV/bit, when sending a CAN message. Input measurement setpoints are interpreted in volts.</p> <p>Current Input Types: 4...20mA or 0...20mA 1uA resolution, accuracy +/- 1% error The offset is in microamps and the resolution is uA/bit, when sending a CAN message. Input measurement setpoints are interpreted in milliamps. Current sense resistor 249Ω</p> <p>Resistive Type with Auto Ranging and Self Calibration: 20 Ω to 250KΩ, +/- 1% error</p> <p>PWM Input Type: PWM Signal Frequency: 0Hz to 10kHz PWM Duty Cycle: 0 to 100% 0.01% resolution, accuracy +/- 1% error</p> <p>Frequency Input Type: 1.3kHz to 15kHz</p> <p>Digital Input Types: Normal, Inverse and Latched Active High with 10K Pullup resistor or Active Low with 10K Pulldown resistor These inputs can be used as an enable or direction command for the controller. The input accepted is active high (switch is connected to a +V signal when ON).</p>

Output Specifications

Output to Motor	<p>3 phase, H-bridge, current sensing per each phase 10A @ 48Vdc nominal continuous 16A @ 24Vdc nominal continuous 16A @ 12Vdc nominal continuous</p> <p>480W nominal power rating Sensorless or hall sensor operation</p> <p>Overcurrent protection is provided at 24A. Short circuit protection is provided. The maximum rated speed and motor rated current are configurable to suit individual motor specifications.</p>
Motor Stop	Shut off with or without ramping
Motor Direction	Motor direction command can be mapped to any input or come from the CAN bus.
Motor Control Mode	<p>Flexible control is provided by user configurable parameters for</p> <ul style="list-style-type: none"> ➤ Open loop speed ➤ Closed loop speed; ➤ Current control; ➤ Position control; or ➤ PID control. <p>The control input to drive the motor can be mapped to any of the universal inputs or the controller can respond to messages from a CAN bus.</p>
Thermal Protection	Thermal protection is built-in and configurable.
Reference Voltage	1 +5V, +/- 0.5%, 200 mA

General Specifications

Microprocessor	TI TMS320F28069, 32-bit, 256 KB flash program memory, 100 KB RAM
Motor Control	<p>Standard embedded software is provided.</p> <p>The configurable properties of the controller are divided into function blocks, namely, the Input Function Block, the Control Logic Block, the Diagnostic Function Block, the CAN Transmit Message Function Block and the CAN Receive Message Function Block.</p> <p>The Motor Parameters setpoint group supports the configuration of the main motor parameters, such as number of pole pairs, rotor position detection, rated RPM of the motor, PWM frequency to use in Motor Phase drive, commutation sequence to use (Hall sensor method only) and whether to use HW current protection.</p> <p>The following parameters are user configurable. <u>Motor Direction</u>: Unidirectional or bi-directional control from an input or the CAN bus. The direction is also configurable. <u>Enable</u>: A universal input can be configured to enable the motor when on. A CAN message can also be used as an enable input. <u>Control Mode</u>: Open loop speed, closed loop speed, current, position or PID control <u>CAN</u>: CAN bus messages control the motor instead of the signal inputs</p>
Diagnostics	There are 3 Diagnostic blocks that can be configured to monitor various parameters of the Controller. Refer to the User Manual for details.
User Interface	<p>Electronic Assistant for <i>Windows</i> operating systems It comes with a royalty-free license for use.</p> <p>The Axiomatic Electronic Assistant requires an USB-CAN converter to link the device's CAN port to a <i>Windows</i>-based PC for initial configuration. Order the EA and Axiomatic USB-CAN as a kit (P/N AX070502), which includes all interconnecting cables. Refer to Figure 2.</p>
Flashing over CAN	The controller software can be reflashed over the CAN connection using the EA.
CAN port	<p>1 CAN port (SAE J1939) Auto baud rate detect functionality for SAE J1939 networks Model AX100281 (CANopen®)</p>

Weight	0.60 lb. (0.27 kg) preliminary
Operating Conditions	-40°C to +125°C (-40°F to 257°F)
Protection Rating	IP67
Enclosure and Dimensions	High Temperature Nylon housing - Deutsch IPD PCB Enclosure (EEC-325X4B) 4.68 x 5.25 x 1.42 inches 119 x 133 x 36 mm (W x L x H excluding mating plugs) <i>Refer to Figure 3.0.</i>
Electrical Connections	Deutsch DTM series 24 pin receptacle (DTM13-12PA-12PB-R008) <i>Refer to Table 2.</i> Wires should be of the appropriate gauge to meet requirements of applicable electric codes and suit the specifications of the connector(s).
Mating Plug Kit	A mating plug kit comprised of all mating connectors is available as P/N: PL-DTM06-12SA-12SB. It includes: TE Deutsch DTM06-12SA; DTM06-12SB; 2 wedgelocks WM12S; and 24 contacts 0462-201-20141. 20 AWG wire is recommended for use with contacts 0462-201-20141.
Mounting	The motor controller should be mounted as close to the battery and/or the motor as possible. Install the unit with appropriate space available for servicing and for adequate wire harness access and strain relief. Mounting holes sized for ¼ inch or M6 bolts. The bolt length will be determined by the end-user's mounting plate thickness. The mounting flange of the controller is 0.63 inches (16 mm) thick. If the module is mounted without an enclosure, it should be mounted vertically with connectors facing left and right to reduce likelihood of moisture entry. The CAN wiring is considered intrinsically safe. The power wires are not considered intrinsically safe and so in hazardous locations, they need to be located in conduit or conduit trays at all times. The module must be mounted in an enclosure in hazardous locations for this purpose. All field wiring should be suitable for the operating temperature range.

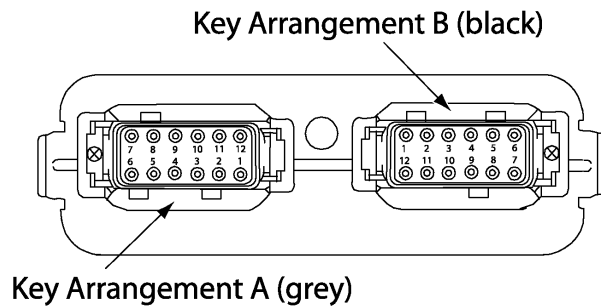

FRONT VIEW 24 PIN RECEPTACLE

Figure 2.0 – Pin out

Table 2.0. Electrical Pin Out			
Grey Connector		Black Connector	
Pin #	Function	Pin #	Function
1	CAN_L	1	+5V Reference
2	MOTOR_C	2	Input 1
3	MOTOR_B	3	Input GND
4	MOTOR_A	4	Input 2
5	Batt +	5	Input 3
6	Batt +	6	Input 4
7	Batt -	7	Ignition Key
8	Batt -	8	HALL_GND
9	MOTOR_A	9	HALL_C
10	MOTOR_B	10	HALL_B
11	MOTOR_C	11	HALL_A
12	CAN_H	12	HALL_5V

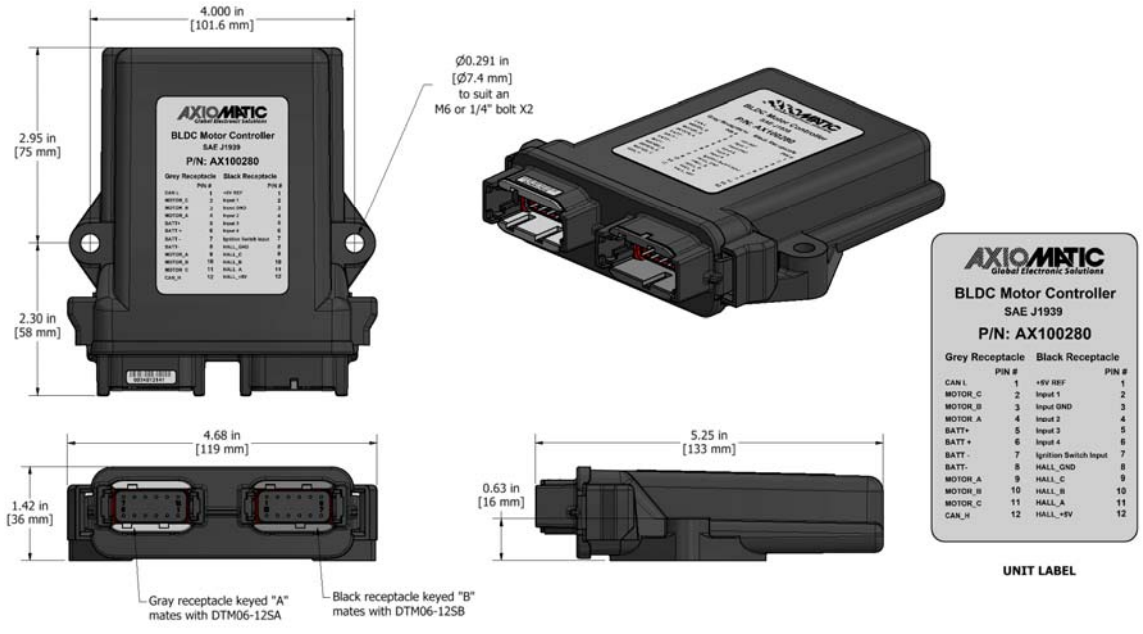

Figure 3.0 - Dimensional Drawing

Notes:

CANopen® is a registered community trademark of CAN in Automation e.V.

Form: TDAX100280-01/20/20