

Unidirectional DC Motor Drive

Encoder Input
CAN networked
P/N: AX100310

Features

- Two universal signal inputs for a speed command input is user selectable through software configuration from the following.
 - a digital input from a switch or other source;
 - 0-5VDC, potentiometer, 0-1V, 0-2.5V, 0-10Vdc, 0-20 mA or 4-20 mA analog input for machine controls; or
 - PWM signal input (0.5-10kHz, 0-100%) for interface to a PLC or engine control module (ECM).
- Encoder Input
- CAN bus input (SAE J1939 or CANopen)
- Speed control command input can be transmitted over SAE J1939
- Half H-bridge motor drive technology
- Provides a 12V or 24V, 25A output to a unidirectional brushed or other DC motor used in electric fan drives and many more applications
- NVM memory retains configuration in case of power loss
- Operating temperatures are -40 to 75°C (-40 to 167°F)
- Encapsulated in a rugged metal base with water-tight connectors, IP67 rated
- Monitors current drawn by the load and transmits info at a constant interval to the CAN bus

Applications:

- Electric Vehicles
- On-highway Vehicles
- Off-highway Equipment
- Fuel Cell Stationary Power
- Industrial Cooling

In electric fan drive applications, a loss of CAN bus communications has the controller output operate at a default value that turns on the motor to allow a cooling fan to operate until communications are re-established or a time-out period elapses.

Ordering Part Numbers:

Unidirectional DC Motor Drive with Encoder Input, 250 kbps SAE J1939 - **AX100310**

Unidirectional DC Motor Drive with Encoder Input, 500 kbps SAE J1939 - **AX100310-01**

Unidirectional DC Motor Drive with Encoder Input, 1 Mbps SAE J1939 - **AX100310-02**

Unidirectional DC Motor Drive with Encoder Input, CANopen - **AX100311**

Accessories – Wire Harnesses

CAN connector wire harness assembly, 2m – P/N: **AX070301**

Power and Output wire harness assembly, 2m – P/N: **TBA**

Mating connector for M12 is not supplied.

Accessories – Electronic Assistant AX070502

BLOCK DIAGRAM

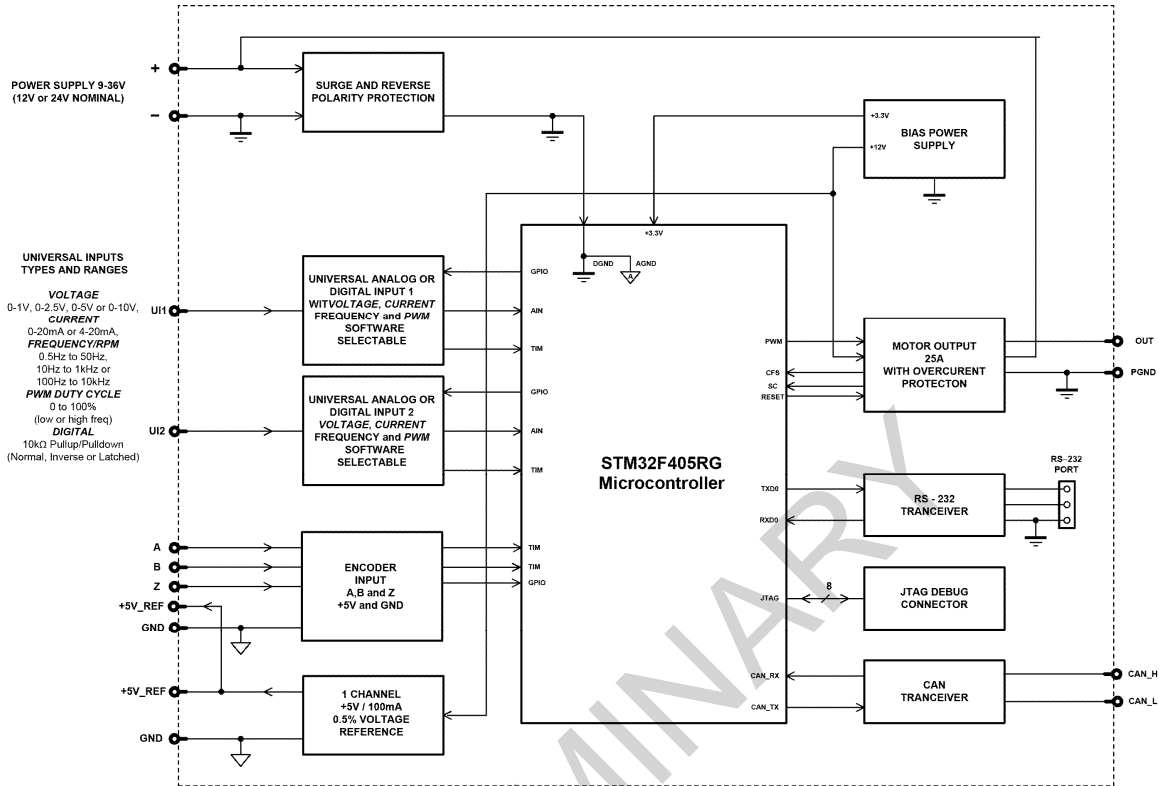

Technical Specifications:

All specifications are typical at nominal input voltage and 25 degrees C unless otherwise specified.

Power Input

Power Supply Input	12V or 24V nominal 9...36 VDC power supply range Transient surge protection is provided. WARNING: This unit is designed for a battery power source. Back EMF from a motor could damage the controller if a bench power supply without voltage regulation is used.
Reverse Polarity Protection	Provided

Input Specifications

CAN Interface CAN_HI CAN_LO	The user can select to control the motor using either a command received from the J1939 bus or a wired command input.
Command Signal Input	Two signal inputs Speed command input is universal and user selectable through software configuration. Choose from one of the following signals: <ul style="list-style-type: none"> ▪ a digital input from a switch or other source (10 kΩ pull-up/pull down – normal, inversed or latched); ▪ potentiometer, 0-1V; 0-2.5V; 0-5V; 0-10Vdc, 0-20 mA or 4-20 mA analog input for machine controls; or ▪ PWM signal input (0.5 Hz to 50 Hz; 10 Hz to 1 kHz; 100 Hz to 10 kHz, 0-100%) for interface to a PLC or engine control module (ECM).
Input GND	Isolated GND connection provided
Quadrature Encoder Input	A, B, Z, +5V and GND connections Maximum Input Frequency 100 kHz Input Amplitude: 0 to Vps. 20kΩ pulldown resistor Rising/Falling edge threshold 4.0V/1.0V +/- 0.1V Number or pulses per revolution are configurable. Custom scaler for encoder steps counter value. There is a configurable polarity of direction of rotation.

Output Specifications

Drive Output	Outputs to a unidirectional, brushed DC motor (other DC motors, contact manufacturer) Half H-Bridge Driver Standard model – 12V or 24V, Up to 25 Amps continuous
Resolution	15-bit PWM
Accuracy	+/- 1% (Duty Cycle)
Protection	Overcurrent and short circuit protection are provided.
+5V Reference	+5V, 100 mA, 0.5%

General Specifications

Microprocessor	STM32F405RG
CAN Interface	Model AX100310: 250 kbps SAE J1939 Model AX100310-01: 500 kbps SAE J1939 Model AX100310-02: 1 Mbps SAE J1939 Model AX100311: CANopen
Monitoring (options)	The controller can monitor the current drawn by the motor and transmits this information at a constant interval over the CAN bus. Other monitoring options include input measured and % Duty Cycle applied to the motor.
Quiescent Current	Contact Axiomatic.
LED Indication	POWER – Green LED's ON Heartbeat – Green LED (Flashing) CAN Transmit & Receive – Red LED's
CAN Termination	120Ω should be connected between CAN_HI and CAN_LO in a mating wire harness assembly (not supplied).

Electrical Connections	<p>1 6 pin DT15-6P-(G003) connector Mates with wire harness AX070301 comprised of a plug assembly (Deutsch IPD P/N: DT06-6S, W6S wedge, 6 gold-plated sockets 0462-201-1631) and 2 m unterminated 16 AWG wire)</p> <p>1 4 pin DTP15-4P connector Mates with wire harness TBA</p> <p>The mating plug for the M12 connector is not supplied.</p> <p>See pin out below in Table 2.0.</p>
Enclosure and Dimensions	Encapsulated unit enclosed in a stainless-steel casing with powder coated steel base <i>Refer to the dimensional drawing.</i>
Operating Conditions	-40 to +75°C (-40 to 167°F) 0 to 95% relative humidity
Storage Temperature	-40 to 100°C (-40 to 212°F)
Weight	1.75 lbs. (0.79 kg)
Vibration	Vibration compliance is suitable for mobile equipment applications.
Protection	IP67

Dimensional Drawing:

Pending

PRELIMINARY

Table 2.0 Pin out:

Connector	PIN#	Function
Command and CAN DT15-6P-(G003)	1	Input GND
	2	+5V Reference
	3	Input
	4	CAN_H
	5	CAN_L
	6	Shield
Power and Output DTP15-4P	1	Battery +
	2	Output +
	3	Output -
	4	Battery -
Encoder Input M12 5-pin P/N: 09-3442- 126-05		
	1	+5V
	2	ENC_A
	3	ENC_B
	4	ENC_Z
	5	GND

Specifications are indicative and subject to change. Actual performance will vary depending on the application and operating conditions. Users should satisfy themselves that the product is suitable for use in the intended application. All our products carry a limited warranty against defects in material and workmanship. Please refer to our Warranty, Application Approvals/Limitations and Return Materials Process as described on www.axiomatic.com/service.html.

Form: TDAX100310-07/30/19