

TECHNICAL DATASHEET #TD3104AX
24V to 48V DC Converter
P/N: PSU4K

Step up 24V to provide isolated 48VDC power in a rugged package...

- 24V DC to 48V DC Converter
- Input operating voltage range from 20 to 30VDC
- Conditioned output of 48VDC \pm 1%, 3A, 144 Watts
- No minimum load requirement
- Switch mode operation delivers high efficiency
- Reverse polarity protection
- Input and output isolation
- Robust, rugged and highly reliable
- Compact size for ease of mounting in confined spaces
- Connects via a 4-pin plug with 2 meter lead wires
- Suitable for moist, high shock and vibration environments
- Operational from -40 to 70°C
- IP65 protection



Wire Harness

Applications:

SCADA Systems
Remote Terminal Units (RTU)
Switchgear
Motor Control Centers
Telecommunications Equipment

Charging/Cranking Battery Based Power Supply Systems
Power Conditioning for Controls & Instrumentation utilizing
DeviceNet or other industrial networks
Off-Highway Equipment Control Systems
Marine Auxiliary and Propulsion Systems

These applications are found in a variety of industries including process industries, general manufacturing, electric utilities, oil & gas, water/wastewater and mobile equipment.

Description: The DC-DC Converter provides clean 48VDC power suitable for instrumentation and control networks or process equipment. For operation under the most harsh and demanding conditions, the unit is fully sealed and enclosed to protect against moisture, shock and vibration. Power from a battery or other source in the range of 20-30VDC is converted to a 48VDC output regulated to 1% and 3 Amps continuous current. Input and output isolation is provided. The unit is designed with extremely rugged surge and transient suppression in addition to sustained over/under voltage protection. With a nameplate rating of 144 Watts of output power, the DC-DC Converter has an efficiency rated at >90%.

Ordering Part Numbers:

Converter with Wire Harness KIT:

PSU4K (KIT SMP-BAC-24VDC-48VDC Converter, WH-DT06-4S-S-16AWG-2M Wire Harness)

Items can also be ordered individually.

Converter: **SMP-BAC-24VDC-48VDC**

Mating Wire Harness, 2 m: **WH-DT06-4S-S-16AWG-2M**

Mating Plug Kit: **PL-DT06-4S**

Block Diagram

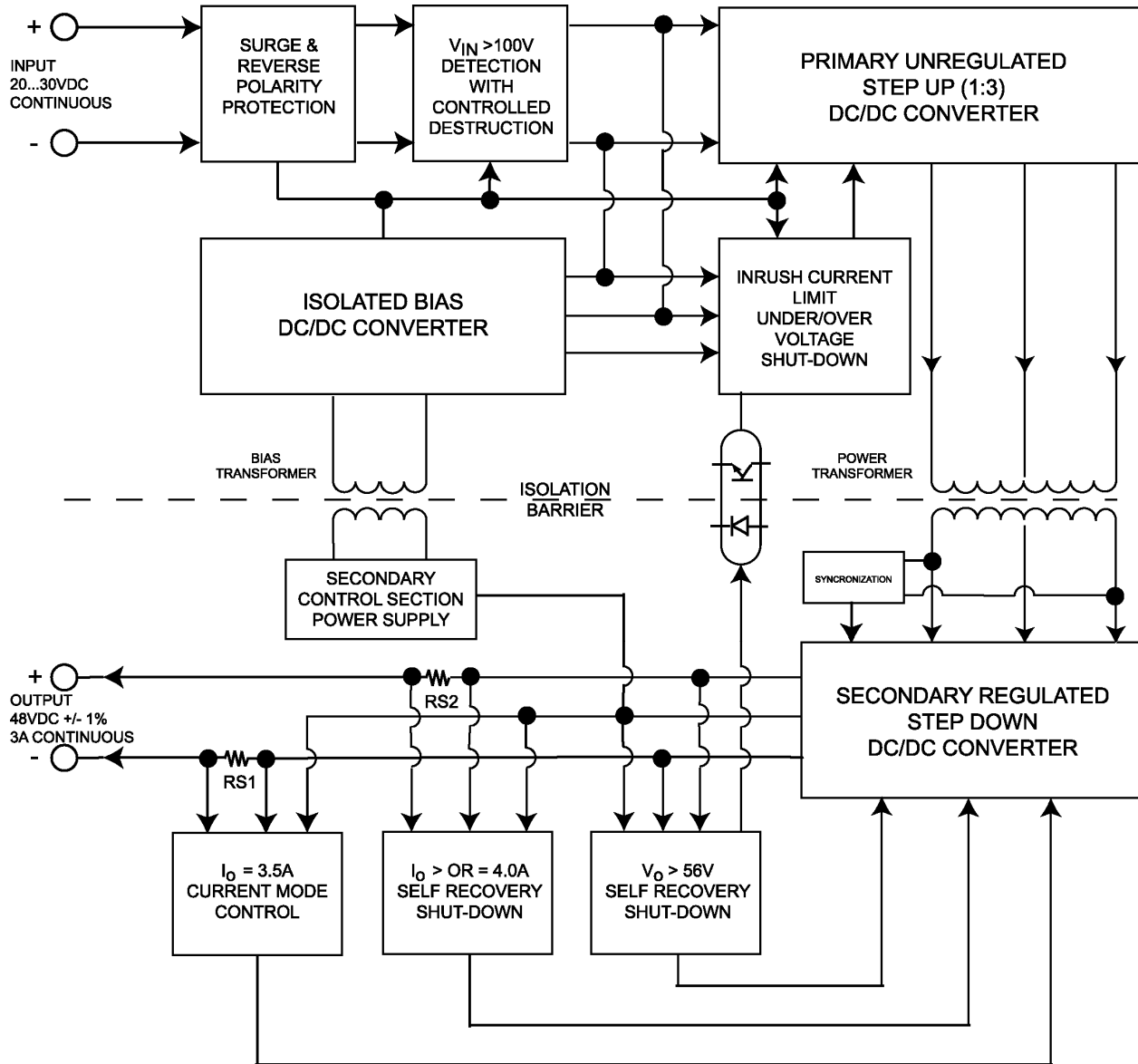

Technical Specifications:

All specifications are typical at nominal input voltage and 25 degrees C unless otherwise specified.

Input Specifications		Output Specifications	
Power Source	24 VDC	Nameplate Rating (Output Power)	144 Watts
Operating Voltage Range	20 - 30VDC continuous	Output Current	3 Amps continuous
Maximum Input Current	8 ADC	Output Voltage	48VDC \pm 1%
Reverse Voltage Protection	Provided	Output Voltage Ripple	V(RIPPLE) \leq 250 mVpp
Over-voltage Shutdown	33VDC	Turn-on Time (with full load)	250 msec max/5% of final value
Under-voltage Shutdown	7.5VDC	Turn-on Overshoot	None
		Stability	Stable at all loads (no minimum load requirement)
		Transient Response	200mV/1.5ms (No Load to Full Load) 100mV/1ms (50% - 100% Load)
		Short Circuit Current	Protection provided Self recovery 3.2A current limit
General Specifications		<h3>Mechanical Dimensions</h3> <p>FRONT VIEW</p> <ul style="list-style-type: none"> Overall width: 5.500 [139.70] Top width: 4.102 [104.19] Right height: 2.375 [60.32] Ground Stud location: Indicated on the left side. <p>BOTTOM VIEW</p> <ul style="list-style-type: none"> Overall height: 7.68 [195.00] Left height: 6.93 [176.00] Internal height: 6.771 [172.00] Right height: 1.024 [26.00] Internal width: 4.724 [120.00] Bottom width: 4.624 [117.46] Bottom hole diameter: ϕ0.250 [ϕ6.35] Top hole diameter: 0.528 [13.42] Top hole offset: 0.347 [8.82] <p>Dimensions: inches [mm]</p>	
Isolation	Isolated from input, output and chassis ground 500V between primary and secondary		
Efficiency	>90%		
Operating Temperature	-40 to 70°C (-40 to 158°F)		
Storage Temperature	-50 to 85°C (-58 to 185°F)		
Humidity	0-99% relative humidity (non-condensing)		
Protection rating	IP65		
Shock	IEC 68-2-27 (30G/11ms)		
Vibration	IEC 68-2-64		
Electrical Connection	Deutsch IPD P/N: DT13-4P Axiomatic Wire Harness: P/N: WH-DT06-4S-S-16AWG-2M (comprised of a 4 pin plug Deutsch IPD P/N:DT06-4S assembly with 2 m (6.5 ft.) of 16 AWG unterminated lead wires)		
	Pin out: Refer to page 4.		
Weight	Converter: 2.02 kg (4.45 lbs.) Converter + Wire Harness: 2.20 kg (4.85 lbs.)		
Packaging and Dimensions	Aluminum enclosure Encapsulated 5.50 x 6.93 x 2.37 inches 139.7 x 176.0 x 60.3 mm (W x L x H excluding connector)		

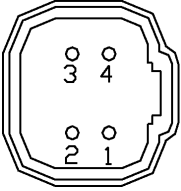
Installation	
<p>Set up</p> <ol style="list-style-type: none"> 1. A UL listed maximum 30A fuse is recommended in the primary circuit to provide protection for the primary wiring. 2. Use four ¼-20 1 inch screws to mount the converter. 3. Ground the unit to chassis ground by attaching a ground strap to the ground stud and locking washer found on the housing. (<i>See mechanical drawing.</i>) 4. Snap the plug connector into the mating receptacle mounted on the converter. 5. Connect the wiring to power and output terminal blocks (provided by customer). 6. Once the load is ready to receive power, turn on the power source to the converter. 	 <p>Connector Pin Out</p> <ul style="list-style-type: none"> 1 Output + (red/white) 2 Output - (black/white) 3 Power - (black) 4 Power + (red)
<p>Grounding</p>	<p>Protective Earth (PE) must be connected to the grounding stud to reduce the risk of electric shock. The conductor providing the connection should have a ring lug and wire larger than or equal to 4 mm² (12 AWG). The ring lug should be placed between the nut and a star washer. (To secure the ground strap, use an 8-32 “K-LOK” locknut, stainless steel, 3/8” O.D.)</p> <p>All chassis grounding should go to a single ground point designated for the machine and all related equipment.</p> <p>The ground strap that provides a low impedance path for EMI should be a ½ inch wide, flat, hollow braid, no more than 12 inches long with a suitable sized ring lug for the module’s grounding lug. It may be used in place of the PE grounding conductor and would then perform both PE and EMI grounding functions.</p>
<p>Mounting</p>	<p>Mounting ledges include holes sized for ¼ inch or M6 bolts. The bolt length will be determined by the end-user’s mounting plate thickness. Typically ¾ inch (20 mm) is adequate.</p> <p>If the module is mounted without an enclosure, it should be mounted vertically with connectors facing left and right to reduce likelihood of moisture entry.</p> <p>All field wiring should be suitable for the operating temperature range of the module.</p> <p>Install the unit with appropriate space available for servicing and for adequate wire harness access (6 inches or 15 cm) and strain relief (12 inches or 30 cm).</p>

Specifications are indicative and subject to change. Actual performance will vary depending on the application and operating conditions. Users should satisfy themselves that the product is suitable for use in the intended application. All our products carry a limited warranty against defects in material and workmanship. Please refer to our Warranty, Application Approvals/Limitations and Return Materials Process as described on www.axiomatic.com/service.html.
Form: TD3104AX-05/14/12

©2012 Axiomatic Technologies Corporation