

Features:

- Ethernet port
- SAE J1939 CAN port
- Four (4) Digital signal inputs
- 12 VDC or 24 VDC nominal
- Operates from -40 to 85°C (-40 to 185°F).
- IP67
- Compact Enclosure, 12-pin Connector (TE Deutsch equivalent)
- Configurable via the Axiomatic Electronic Assistant or via Ethernet



Applications:

- Control panels
- Machine automation

Ordering Part Numbers:

4 Digital Inputs Controller, Ethernet, SAE J1939, 250 kbps:
AX032150

Accessories:

Axiomatic Electronic Assistant Configuration KIT, P/Ns: **AX070502** or **AX070506K**
PL-DTM06-12SA Mating Plug Kit :1x DTM06-12SA, 1x WM-12S, 12x 0462-201-20141, 6x 0413-204-2005 Sealing Plug

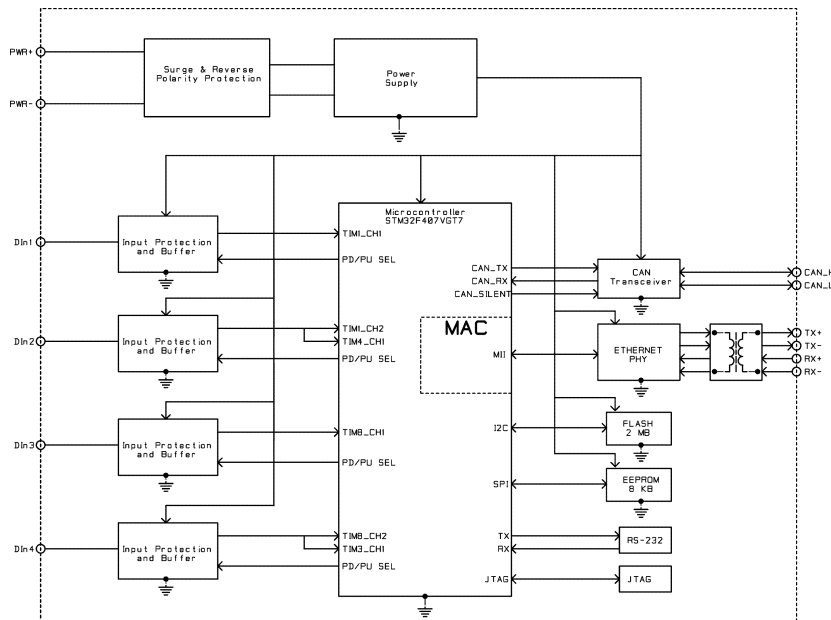

Figure 1.0 – Block Diagram

Technical Specifications:

Specifications are indicative and subject to change. Actual performance will vary depending on the application and operating conditions. Users should satisfy themselves that the product is suitable for use in the intended application. All our products carry a limited warranty against defects in material and workmanship. Please refer to our Warranty, Application Limitations & Return Materials Process as described on <https://www.axiomatic.com/service/>.

Power Supply

Power Supply Input	12 VDC or 24 VDC nominal 9...36 VDC power supply range
Protection	Reverse polarity protection is provided up to -50 V. Under-voltage protection is provided with hardware shutdown at 4 V. Over-voltage protection is provided with hardware shutdown at 41 V.

Inputs

Inputs	4 Digital Signal Inputs Active High or Active Low with user selectable pull-up (+5 V)/pull-down (GND) through 10 kOhm resistor Digital input pairs (1&2 and/or 3&4) can be configured as standard A & B Phase Encoder inputs Frequency range: 0-100 kHz Amplitude: 0-32 V The digital input return path should be connected to the Power Supply Negative pin.
Input Grounds	Provided

General Specifications

Microcontroller	STM32F407VGT7, 32-bit, 1 MByte flash memory
Typical Quiescent Current	60 mA @ 12 VDC; 30 mA @ 24 VDC Typical
CAN Communications	1 CAN port (SAE J1939) Model: AX032150 – 250 kbps baud rate
Control Logic	Refer to the user manual.
Ethernet	One 10/100 Mbit Ethernet port 10BASE-T 100BASE-Tx (Auto-configuration and full duplex is supported.) Auto-MDIX
Software Reflashing	Axiomatic Electronic Assistant Configuration KIT, P/Ns: AX070502 or AX070506K
User Interface	The Electronic Assistant KITS, P/Ns: AX070502 or AX070506K for <i>Windows</i> operating systems come with a royalty-free license for use on multiple computers. They include an Axiomatic USB-CAN converter to link the device's CAN port to a <i>Windows</i> -based PC. The controller is also configurable via the Ethernet.
Operating Conditions	-40 to 85 °C (-40 to 185 °F)
Storage Temperature	-55 to 125 °C (-67 to 257 °F)
Protection	IP67
Weight	0.15 lb. (0.068 kg)
Vibration	Random Vibration: 6.0 Grms peak Based on ISO16750-3, Section 4.1.2.7
Enclosure and Dimensions	Molded Enclosure, integral connector Nylon 6/6, 30% glass Ultrasonically welded Flammability Rating: UL 3.54 x 2.75 x 1.31 inches (90.09 x 70.00 x 33.35 mm) L x W x H including integral connector Refer to the dimensional drawing, Figure 2.0.

Electrical Connections	<p>Integral 12-pin receptacle (TE Deutsch equivalent P/N: DTM04-12PA) Mates to: PL-DTM06-12SA Mating Plug Kit : 1x DTM06-12SA, 1x WM-12S, 12x 0462-201-20141, 6x 0413-204-2005 Sealing Plug</p> <table border="1" data-bbox="548 331 1000 716"> <thead> <tr> <th>PIN #</th> <th>FUNCTION</th> </tr> </thead> <tbody> <tr><td>1</td><td>BATT-</td></tr> <tr><td>2</td><td>TX+</td></tr> <tr><td>3</td><td>RX+</td></tr> <tr><td>4</td><td>Digital Input 3</td></tr> <tr><td>5</td><td>Digital Input 4</td></tr> <tr><td>6</td><td>CAN_H</td></tr> <tr><td>7</td><td>CAN_L</td></tr> <tr><td>8</td><td>Digital Input 2</td></tr> <tr><td>9</td><td>Digital Input 1</td></tr> <tr><td>10</td><td>RX-</td></tr> <tr><td>11</td><td>TX-</td></tr> <tr><td>12</td><td>BATT+</td></tr> </tbody> </table>	PIN #	FUNCTION	1	BATT-	2	TX+	3	RX+	4	Digital Input 3	5	Digital Input 4	6	CAN_H	7	CAN_L	8	Digital Input 2	9	Digital Input 1	10	RX-	11	TX-	12	BATT+
PIN #	FUNCTION																										
1	BATT-																										
2	TX+																										
3	RX+																										
4	Digital Input 3																										
5	Digital Input 4																										
6	CAN_H																										
7	CAN_L																										
8	Digital Input 2																										
9	Digital Input 1																										
10	RX-																										
11	TX-																										
12	BATT+																										
Network Termination	<p>It is necessary to terminate the network with external termination resistors. The resistors are 120 Ohm, 0.25 W minimum, metal film or similar type. They should be placed between CAN_H and CAN_L terminals at both ends of the network.</p>																										
Mounting	<p>Mounting holes are sized for #8 or M4 bolts. The bolt length will be determined by the end-user's mounting plate thickness. The mounting flange of the controller is 0.425 inches (10.8 mm) thick.</p> <p>If the module is mounted without an enclosure, it should be mounted vertically with connectors facing left or right to reduce likelihood of moisture entry.</p> <p>The CAN wiring is considered intrinsically safe. The power wires are not considered intrinsically safe and so in hazardous locations, they need to be located in conduit or conduit trays at all times. The module must be mounted in an enclosure in hazardous locations for this purpose.</p> <p>No wire or cable harness should exceed 30 meters in length. The power input wiring should be limited to 10 meters.</p> <p>All field wiring should be suitable for the operating temperature range.</p> <p>Install the unit with appropriate space available for servicing and for adequate wire harness access (6 inches or 15 cm) and strain relief (12 inches or 30 cm).</p>																										

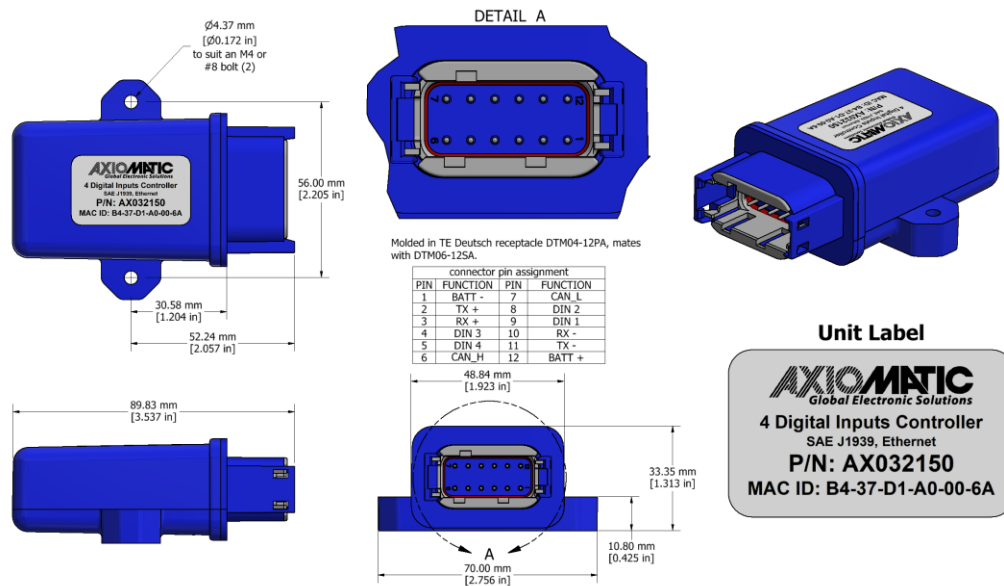

Figure 2.0 – Dimensional Drawing of AX032150

Form: TDAX032150-09/29/2025