

# BLDC Motor Controller

**CANopen®**

*Variable Speed Control, Onboard Inputs  
 12, 24, or 48 V Nominal Input  
 Up to 480 W Output  
 High Temperature Operation  
 EDS File for Configuration  
 P/N: AX100281*

## Applications

Motor variable speed, position and/or flow control in lift equipment, electric vehicles for material handling, trucks, cranes and hoists, hydraulic tail lifts and winches, golf carts, military equipment, mobile pumps, and hydraulic powerpacks

## Ordering Part Numbers

BLDC Motor Controller, CANopen® – P/N: **AX100281**  
 SAE J1939 version – P/N: **AX100280**

### Accessories:

#### EDS File

Mating Plugs KIT – P/N: PL-DTM06-12SA-12SB



## Features

- Highly efficient and robust design for unidirectional or bi-directional BLDC motor control
- Up to 480 W continuous output to the motor at 48 V output voltage (Power output will be lower at lower output voltages.)
- Hall effect sensor feedback or sensorless operation
- Flexible control with user selectable modes of open loop speed, closed loop speed, current control, or PID control (such as position control)
- 4x inputs user configurable as voltage, current, resistive, frequency, PWM, digital, or quadrature encoder type
- The control input to drive the motor can be mapped to any of the universal inputs or the controller can respond to messages from a CAN bus.
- Direction control can be mapped to any of the inputs or a CAN message
- User configurable enable function can be mapped to any of the inputs or a CAN message
- Ignition switch input turns power ON to unit.
- Output can be coded as feedback messages sent to the CAN bus
- 1x reference voltage (5 V, 200 mA max.) to power an external sensor or potentiometer
- Operational from 9 to 65 V (12, 24, or 48 V nominal)
- 1x CANopen® port (SAE J1939 model available)
- Compact, sealed, rugged, IP67-rated enclosure
- Suitable for moist environments
- Operational up to 125 °C (257 °F)
- EDS file for configuration

## Description

The AX100281 BLDC Motor Controller has 4 universal inputs that can be configured to measure voltage, current, resistive, frequency, PWM duty cycle, digital voltage level (on/off), or quadrature encoder. It accepts 12, 24, or 48 VDC nominal input power. The controller can drive brushless DC motors up to 480 W continuous (at 48 V output voltage) equipped with Hall sensors. Power output will be lower at lower output voltages. Sensorless motor control using back-EMF rotor position detection is also supported.

Measured input data can be sent to a CANopen® network as is or used in the BLDC controller logic for controlling how the BLDC motor is driven.

Standard CANopen® tools can be used to configure the controller.

A rugged enclosure, IP67 rating, and high temperature operation up to 125 °C (257 °F) ensure that the controller is suitable for mounting in harsh equipment environments.

## Block Diagram

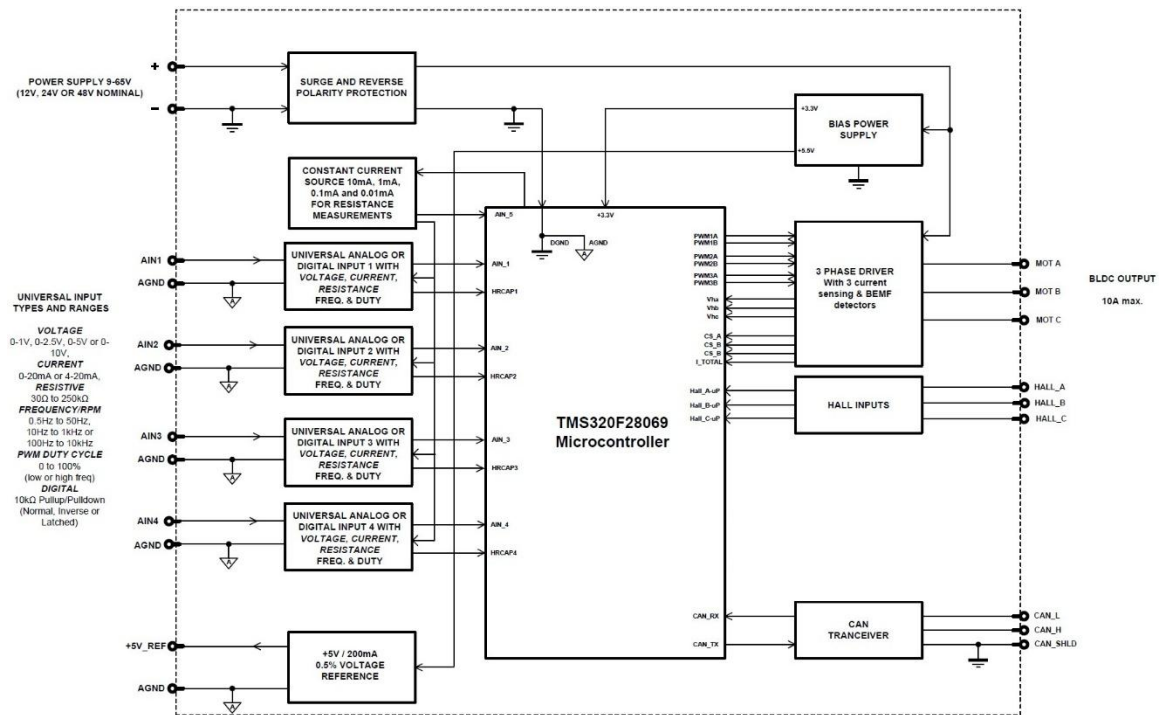

Figure 1 – Block Diagram

## Technical Specifications

Specifications are indicative and subject to change. Actual performance will vary depending on the application and operating conditions. Users should satisfy themselves that the product is suitable for use in the intended application. All our products carry a limited warranty against defects in material and workmanship. Please refer to our Warranty, Application Limitations & Return Materials Process as described on <https://www.axiomatic.com/service/>.

All specifications are typical at nominal input voltage and 25 °C unless otherwise specified.

### Power Supply

Power Input	12, 24, or 48 VDC nominal (9 to 65 VDC range)
Surge Protection	Provided
Reverse Polarity Protection	Provided up to -100 VDC
Undervoltage Protection	Built-in

### Inputs

Universal and Resistive Inputs	<p>4x universal inputs are user selectable as voltage, current, resistive, frequency, PWM, or digital types.</p> <p><u>Voltage Type:</u>            Range: 0-5 or 0-10 VDC            Resolution: 1 mV            Accuracy: ±1 % error            The offset is in mV, and the resolution is mV/bit, when sending a CAN message.            Input measurement setpoints are interpreted in V.</p> <p><u>Current Type:</u>            Range: 0-20 or 4-20 mA            Resolution: 1 µA            Accuracy: ±1 % error            Current Sense Resistor: 249 Ω            The offset is in mA, and the resolution is µA/bit, when sending a CAN message.            Input measurement setpoints are interpreted in mA.</p> <p><u>Resistive Type:</u>            Range: 20 Ω to 250 kΩ            Accuracy: ±1 % error            Auto-ranging and self-calibration</p> <p><u>Frequency Type:</u>            Range: 0.5 Hz to 15 kHz</p> <p><u>PWM Type:</u>            Range: Up to 10 kHz            Duty Cycle: 0 to 100 %            Resolution: 0.01 %            Accuracy: ±1 % error</p> <p><u>Digital Type:</u>            Normal, inverse, and latched            Active high with 10 kΩ pull-up resistor or active low with 10 kΩ pull-down resistor            These inputs can be used as an enable or direction command for the controller. The input accepted is active high (switch is connected to a +V signal when ON).</p> <p><u>Quadrature Encoder Type:</u>            See “Motor Outputs and Feedback Inputs” below.</p> <p>Amplitude: up to +Vsupply            12-bit analog to digital resolution            Protected against short to ground</p> <p>Input properties are user configurable. Any input on the controller can be sent as a CANopen® PDO to the CANopen® network.</p>
Ignition Switch Input	<p>The ignition key input turns the unit power ON.            Minimum: 2.5 V            Maximum: +Vps</p>
Input Ground	1x provided

## Motor Outputs and Feedback Inputs

Output to Motor	<p>3-phase, H-bridge, current sensing per each phase Hall sensor or sensorless operation The maximum rated speed and motor rated current are configurable to suit individual motor specifications. Up to 480 W continuous output to the motor at 48 V output voltage (Power output will be lower at lower output voltages.)</p> <p>Short circuit protection is provided. Overcurrent protection is provided at 24 A.</p>
Motor Stop	Shut off with or without ramping
Motor Direction	Motor direction command can be mapped to any input or come from the CAN bus.
Motor Feedback Inputs	<p>Standard open collector/drain input type for Hall effect sensor 1 k<math>\Omega</math> pull-up to +5 V per input +5 V supply and ground connection pins are provided.</p> <p>Sensorless operation is also available.</p> <p><b>Note:</b> The controller can read quadrature encoder using the Universal Input pins. (The Hall sensor inputs are separate and used only for reading rotor position information from a BLDC with Hall sensors.) The quadrature signals should be connected to Universal Input 1 and 2. This is the minimum configuration. It is also possible to connect the Index and Strobe signals from the encoder to Universal Inputs 3 and 4, but these are optional. The controller will detect Position Count, Direction, and Speed from the quadrature signals.</p>
Motor Control Mode	<p>Flexible control is provided by user configurable parameters for:</p> <ul style="list-style-type: none"> <li>• Open loop speed;</li> <li>• Closed loop speed;</li> <li>• Current control; or</li> <li>• PID control (such as position control)</li> </ul> <p>The control input to drive the motor can be mapped to any of the universal inputs or the controller can respond to messages from a CAN bus.</p>
Thermal Protection	Thermal protection is built-in and configurable.
Reference Voltage	1x +5 V, $\pm 0.5\%$ , 200 mA

## Dimensional Drawing

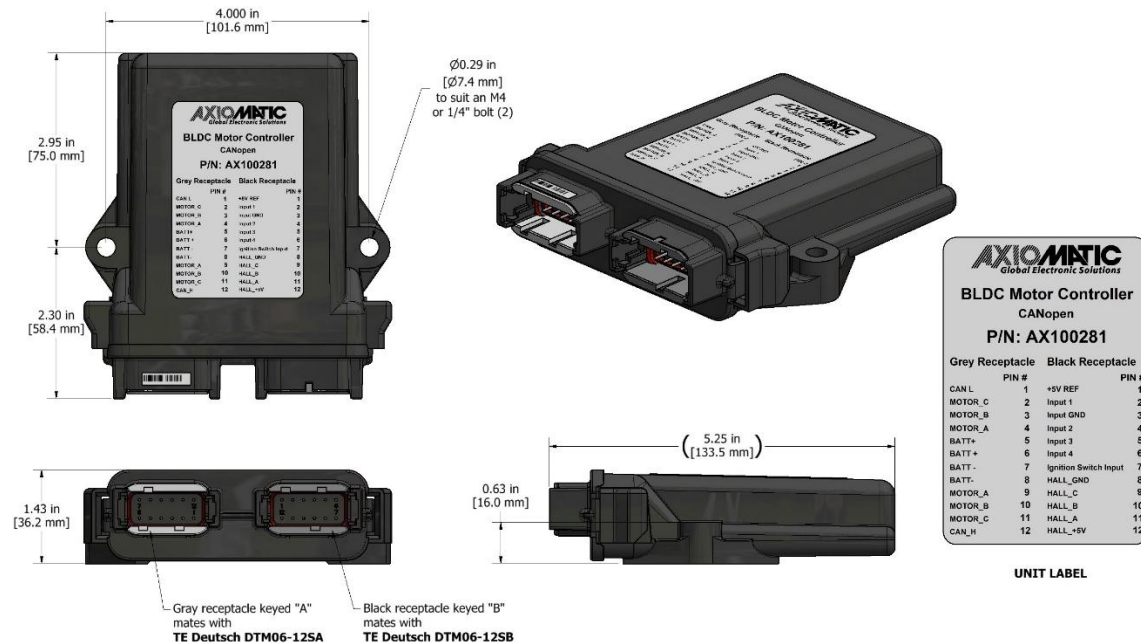
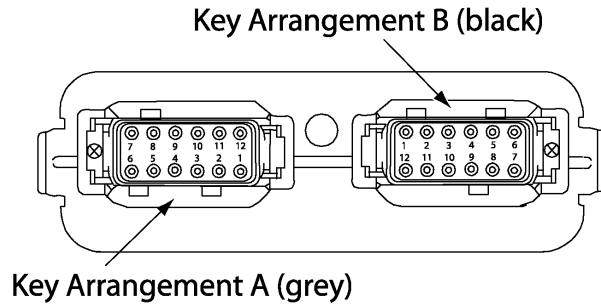

Figure 2 – Dimensional Drawing

## General Specifications

Microcontroller	TI TMS320F28069, 32-bit, 256 KB flash program memory, 100 KB RAM
Motor Control	<p>Standard embedded software is provided.</p> <p>The following parameters are user configurable.</p> <ul style="list-style-type: none"> <li>• <b>Motor Direction:</b> Unidirectional or bi-directional control from an input or the CAN bus. The direction is also configurable.</li> <li>• <b>Enable:</b> A universal input can be configured to enable the motor when on. A CAN message can also be used as an enable input.</li> <li>• <b>Control Mode:</b> Open loop speed, closed loop speed, current, or position control</li> <li>• <b>CAN:</b> CAN bus messages control the motor instead of the signal inputs</li> </ul> <p>Refer to the user manual for more details.</p>
Diagnostics	Refer to the User Manual for details.
CAN port	<p>1x CANopen® port.</p> <p>Supported baud-rates: 10 kbit/s, 20 kbit/s, 50 kbit/s, 125 kbit/s (default), 250 kbit/s, 500 kbit/s, 800 kbit/s, or 1 Mbit/s</p> <p>SAE J1939 version: AX100280</p>
User Interface	An EDS file is provided to interface with the device using standard CANopen® tools.
Firmware Reflashing	The controller software can be reflashed over the CAN connection using the Axiomatic Electronic Assistant KIT – P/N: AX070502 or AX070506K.
Compliance	RoHS
Protection Rating	IP67
Operating Temperature	-40 to 125 °C (-40 to 257 °F)
Storage Temperature	-40 to 125 °C (-40 to 257 °F)
Weight	0.60 lb. (0.27 kg)
Enclosure	<p>TE Deutsch Enclosure (P/N: EEC-325X4B)</p> <p>High Temperature Nylon housing</p> <p>4.68 in. x 5.25 in. x 1.42 in. (119 mm x 133 mm x 36 mm)</p> <p>(W x L x H excluding mating plugs)</p> <p>Refer to Dimensional Drawing.</p>
Mounting	<p>The motor controller should be mounted as close to the battery and/or the motor as possible. Install the unit with appropriate space available for servicing and for adequate wire harness access and strain relief.</p> <p>Mounting holes sized for ¼ in. or M6 bolts. The bolt length will be determined by the user's mounting plate thickness. The mounting flange of the controller is 0.63 in. (16 mm) thick. If the module is mounted without an enclosure, it should be mounted vertically with connectors facing left and right to reduce likelihood of moisture entry. The CAN wiring is considered intrinsically safe. The power wires are not considered intrinsically safe and so in hazardous locations, they need to be located in conduit or conduit trays at all times. The module must be mounted in an enclosure in hazardous locations for this purpose. All field wiring should be suitable for the operating temperature range.</p>
Electrical Connections	<p>24-pin receptacle (TE Deutsch P/N: DTM13-12PA-12PB-R008)</p> <p>Refer to Table 1 for pin out.</p> <p>Wires should be of the appropriate gauge to meet requirements of applicable electric codes and suit the specifications of the connector(s).</p>
Mating Plug KIT	<p>A mating plug KIT is available from Axiomatic under P/N: PL-DTM06-12SA-12SB. It consists of TE Deutsch P/Ns: DTM06-12SA, DTM06-12SB, 2x wedgelocks WM12S, and 24x contacts 0462-201-20141.</p> <p>20 AWG wire is recommended for use with contacts 0462-201-20141.</p>



**FRONT VIEW 24 PIN RECEPTACLE**

<b>Table 1. Electrical Pin Out</b>			
<b>Grey Connector</b>		<b>Black Connector</b>	
<b>Pin</b>	<b>Function</b>	<b>Pin</b>	<b>Function</b>
1	CAN Low	1	+5 V Reference
2	Motor C	2	Input 1
3	Motor B	3	Input Ground
4	Motor A	4	Input 2
5	Battery +	5	Input 3
6	Battery +	6	Input 4
7	Battery -	7	Ignition Switch Input
8	Battery -	8	Hall Sensor Ground
9	Motor A	9	Hall Sensor C
10	Motor B	10	Hall Sensor B
11	Motor C	11	Hall Sensor A
12	CAN High	12	Hall Sensor +5 V

*Note: CANopen® is a registered community trademark of CAN in Automation e.V.*

Form: TDAX100281-05/07/2026