

## 4 Channel Strain Gauge CAN Controller

CAN (SAE J1939)

P/N: AX200000

### Features:

- 4 channels for inputs from 4-wire full bridge strain gauges:
  - +/- 19.5 mV to +/- 2.5 Vdc (selectable)
- 1 digital input, 1 digital on/off output
- 1 interlock (relay) output
- 12V, 24Vdc (nominal) power input
- 4 +5V excitation connections
- 1 CAN port (SAE J1939)
- Rugged packaging and connectors (Deutsch IPD)
- Standard control logic
- Developed with Simulink®
- User configurable with Axiomatic Electronic Assistant®



### Description:

The 4 Channel Strain Gauge CAN controller accepts up to four 4-wire strain gauge connections. The input range is user selectable from +/- 19.5 mV to +/- 2.5 Vdc. It interfaces with the machine's CAN network (SAE J1939). The measurement rate is 2.5 scans per second and the update rate is 400 ms for all 4 channels. Standard embedded software is provided. Rugged IP67 rated packaging and a power supply input of 12Vdc or 24Vdc nominal suits applications in the harsh environment of mobile equipment with on-board battery power. All setpoints are user configurable using the Electronic Assistant®.

### Applications:

- construction equipment, lift equipment and cranes

### Ordering Part Numbers:

Controller, SAE J1939, 250 kbps baud rate: **AX200000**  
 Controller, SAE J1939, 500 kbps baud rate: **AX200000-01**  
 Controller, SAE J1939, 1 Mbps baud rate: **AX200000-02**

#### Accessories:

**PL-DTM06-12SA-12SB** Mating Plug Kit (1 DTM06-12S, DTM06-12SB, 2 W12S, 24 contacts)  
 Electronic Assistant® Configuration KIT: **AX070502**

### Control Logic:

The AX200000 is a highly programmable controller - allowing the user to configure it for their application. Its input, logical and mathematical function blocks allow the controller to support a wide variety of load cells to fit customer's various applications.

All inputs and logical function blocks on the unit are inherently independent from one another, but can be programmed to interact in a large number of ways. The logical function blocks (software) are shown below.

The various function blocks supported by the module have configurable setpoints using the Axiomatic Service Tool, Electronic Assistant (EA).

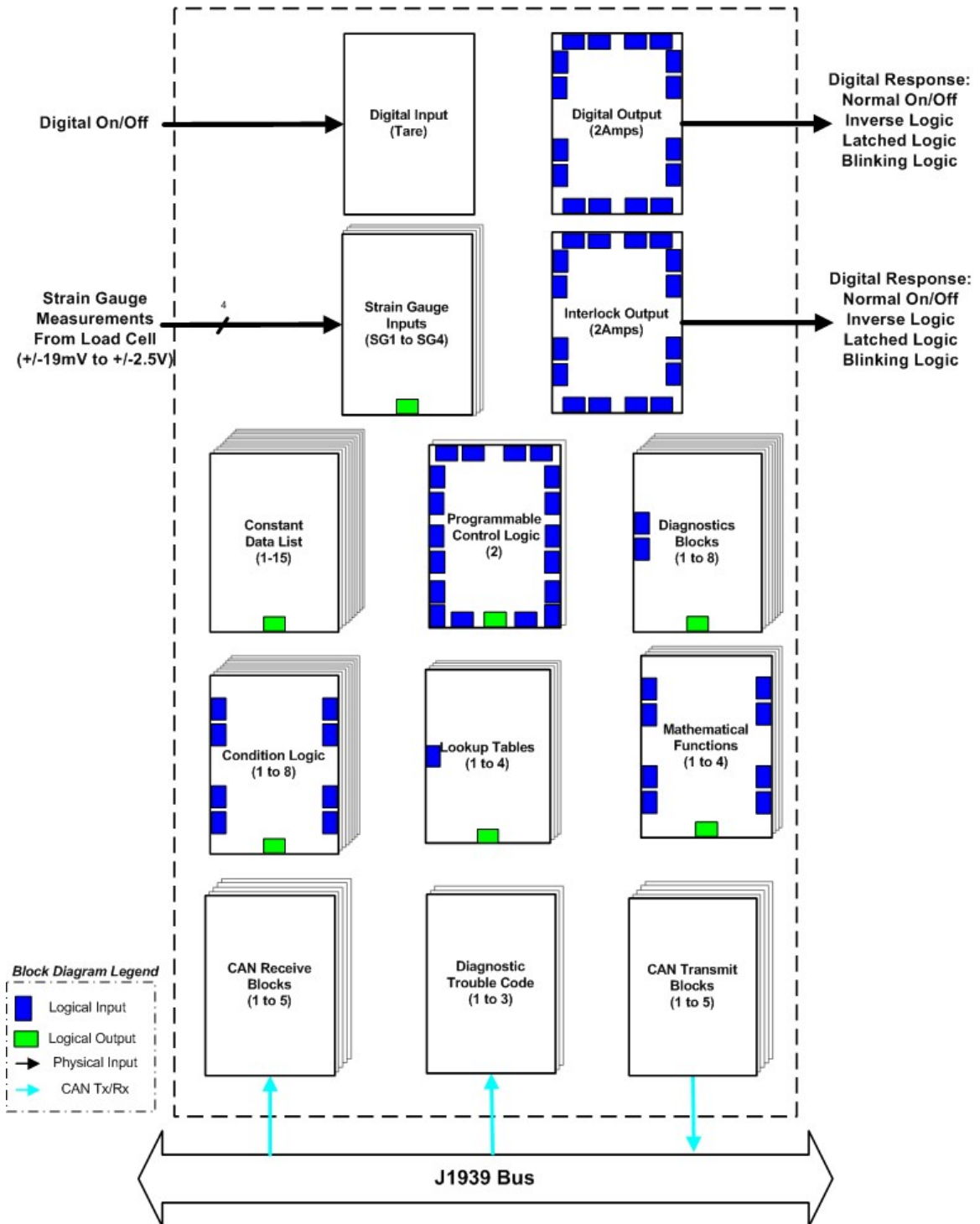

## BLOCK DIAGRAM:

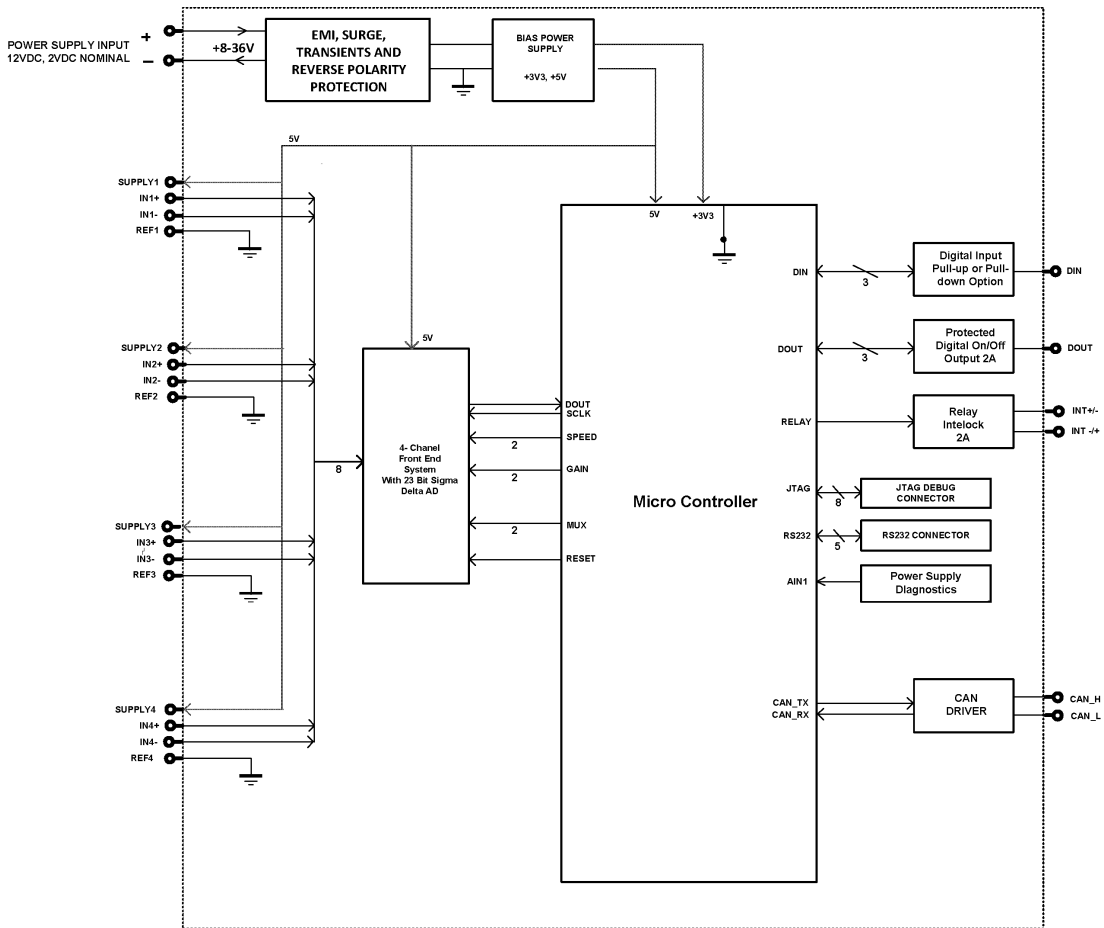

## Dimensions:

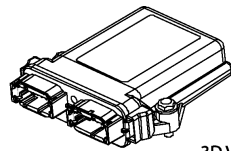

3D VIEW  
Housing with 24 Pin Receptacle

## HOUSING DIMENSIONS

Housing Material: High Temperature Nylon (Black)

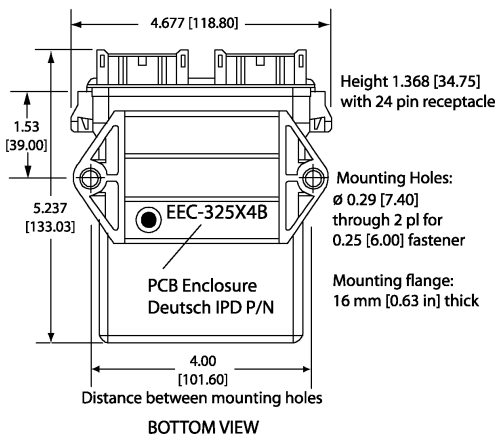

FRONT VIEW 24-PIN RECEPTACLE (NOT TO SCALE)

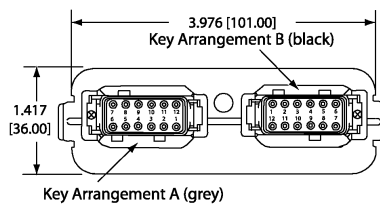

Mating Plug Assemblies for 24-pin receptacle:  
 Deutsch IPD P/N: DTM06-125A and DTM06-125B  
 with wedgelocks WM125 and contacts  
 (Contact factory for contact specification.)

Dimensions: inches [mm]  
 excluding mating plug(s)

## Technical Specifications:

Specifications are indicative and subject to change. Actual performance will vary depending on the application and operating conditions. Users should satisfy themselves that the product is suitable for use in the intended application. All our products carry a limited warranty against defects in material and workmanship. Please refer to our Warranty, Application Limitations & Return Materials Process as described on <https://www.axiomatic.com/service/>.

### Power Input Specifications

Power Supply Input - Nominal	12 or 24Vdc nominal operating voltage 8...36 Vdc power supply range for voltage transients
Surge Protection	Provided
Reverse Polarity Protection	Provided

### Input Specifications

Strain Gauge Inputs	4 Channels Accepts 4-wire Strain Gauge inputs Input range selectable from +/- 19.5 mV to +/- 2.5 Vdc. All input channels have excitation and ground connections provided. All inputs send a message to the CAN bus.
Measurement rate	The measurement rate is 2.5 scans per second for all 4 channels. The update rate is 400 mSec. for all 4 channels.
Common-mode	Common-mode rejection is > 100 db@ 1V p-p, simultaneous 50/60 Hz. Common mode input range is +/- 3.5V maximum.
Resolution	18.2-Bit noise-free minimum
Drift	Overall drift with temperature is 50 ppm/°C of span (maximum).
Input Accuracy	+/- 0.5% throughout the entire range of the input
Excitation	4 +5V excitation connections
Other Input	1 Digital Input Active High to 5V or Active Low to GND Configurable Pull Up or Pull Down Resistor Amplitude: up to +Vps
Grounds	4 GND connections

### Output

Digital On/Off Output	1 Digital On/Off Output Fully protected high side digital switch with low current readings 2A Overcurrent, overvoltage and undervoltage protection is provided.
Relay Output	An interlock relay with 2 contact pins is provided. 2A (nominal)

### General Specifications

Microprocessor	STM32F103CBT7
Communications	1 CAN port (SAE J1939) Models: AX200000 – 250 kbps baud rate AX200000-01 – 500 kbps baud rate AX200000-02 – 1Mbps baud rate
Control Logic	Standard embedded control logic is provided. Refer to the User Manual for details. Application-specific control logic is available on request.
Simulink®	Model AX200000 was developed using Simulink®. Simulink® is a model-based design tool from Mathworks®. Using Simulink®, the OEM machine designer may simulate their control system with the Axiomatic module included. This permits fine tuning of the design parameters and testing of functionality prior to machine prototype installation.

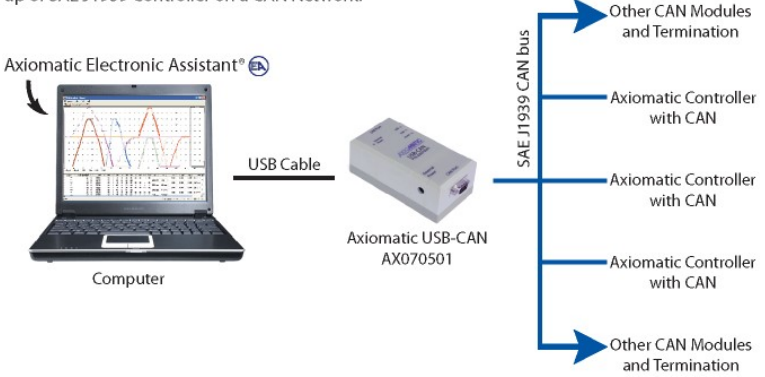
<p>User Interface</p>	<p>Electronic Assistant®, P/N: AX070502  User configuration and diagnostics are provided with the Axiomatic Electronic Assistant®. The Axiomatic Service Tool is a <i>Windows</i>-based graphical user interface that allows easy configuration of the controller setpoints.</p> <p>Set up of SAE J1939 Controller on a CAN Network:</p> 																																																								
<p>SAE J1939 Compliance</p>	<p>The ECU is compliant with the following SAE J1939 standards.</p> <ul style="list-style-type: none"> <li>• J1939 Recommended Practice for a Serial Control and Communications Vehicle Network, SAE, April 2011</li> <li>• J1939/21 Data Link Layer, SAE, December 2010</li> <li>• J1939/71 Vehicle Application Layer, SAE, March 2011</li> <li>• J1939/81 Network Management, SAE, May 2003</li> </ul>																																																								
<p>Electrical Connections</p>	<p>Deutsch DTM series 24 pin receptacle: DTM13-12PA-12PB-R008  Mating plug: Deutsch DTM06-12SA and DTM06-12SB with 2 wedgelocks (WM12S) and 24 contacts (0462-201-20141).  20 AWG wire is recommended for use with contacts 0462-201-20141.</p> <table border="1" data-bbox="670 1020 1307 1428"> <thead> <tr> <th colspan="2">Grey Connector</th> <th colspan="2">Black Connector</th> </tr> <tr> <th>Pin #</th> <th>Function</th> <th>Pin #</th> <th>Function</th> </tr> </thead> <tbody> <tr> <td>1</td> <td>+5V Excitation 1</td> <td>1</td> <td>GND 3</td> </tr> <tr> <td>2</td> <td>IN 1+</td> <td>2</td> <td>IN 3-</td> </tr> <tr> <td>3</td> <td>+5V Excitation 2</td> <td>3</td> <td>GND 4</td> </tr> <tr> <td>4</td> <td>IN 2+</td> <td>4</td> <td>IN 4-</td> </tr> <tr> <td>5</td> <td>Tare Input</td> <td>5</td> <td>Interlock +/-</td> </tr> <tr> <td>6</td> <td>BATT-</td> <td>6</td> <td>CAN_H</td> </tr> <tr> <td>7</td> <td>BATT+</td> <td>7</td> <td>CAN_L</td> </tr> <tr> <td>8</td> <td>Digital Output</td> <td>8</td> <td>Interlock -/+</td> </tr> <tr> <td>9</td> <td>IN 2 -</td> <td>9</td> <td>IN 4+</td> </tr> <tr> <td>10</td> <td>GND 2</td> <td>10</td> <td>+5V Excitation 4</td> </tr> <tr> <td>11</td> <td>IN 1 -</td> <td>11</td> <td>IN 3+</td> </tr> <tr> <td>12</td> <td>GND 1</td> <td>12</td> <td>+5V Excitation 3</td> </tr> </tbody> </table>	Grey Connector		Black Connector		Pin #	Function	Pin #	Function	1	+5V Excitation 1	1	GND 3	2	IN 1+	2	IN 3-	3	+5V Excitation 2	3	GND 4	4	IN 2+	4	IN 4-	5	Tare Input	5	Interlock +/-	6	BATT-	6	CAN_H	7	BATT+	7	CAN_L	8	Digital Output	8	Interlock -/+	9	IN 2 -	9	IN 4+	10	GND 2	10	+5V Excitation 4	11	IN 1 -	11	IN 3+	12	GND 1	12	+5V Excitation 3
Grey Connector		Black Connector																																																							
Pin #	Function	Pin #	Function																																																						
1	+5V Excitation 1	1	GND 3																																																						
2	IN 1+	2	IN 3-																																																						
3	+5V Excitation 2	3	GND 4																																																						
4	IN 2+	4	IN 4-																																																						
5	Tare Input	5	Interlock +/-																																																						
6	BATT-	6	CAN_H																																																						
7	BATT+	7	CAN_L																																																						
8	Digital Output	8	Interlock -/+																																																						
9	IN 2 -	9	IN 4+																																																						
10	GND 2	10	+5V Excitation 4																																																						
11	IN 1 -	11	IN 3+																																																						
12	GND 1	12	+5V Excitation 3																																																						

Enclosure and Dimensions	High Temperature Nylon housing - Deutsch IPD PCB Enclosure (EEC-325X4B) 4.62 x 5.24 x 1.43 inches 117.42 x 133.09 x 36.36 mm (W x L x H excluding mating plugs)
Operating Conditions	-40 to 85°C (-40 to 185°F)
Weight	0.50 lb. (0.23 kg)
Protection	IP67
Vibration	MIL-STD-202G, Test 204D and 214A (Sine and Random) 10 g peak (Sine) 7.86 Grms peak (Random)
Shock	MIL-STD-202G, Test 213B 50g
Mounting	Mounting holes sized for ¼ inch or M6 bolts. The bolt length will be determined by the end-user's mounting plate thickness. The mounting flange of the controller is 0.63 inches (16 mm) thick.  All field wiring should be suitable for the operating temperature range.  Install the unit with appropriate space available for servicing and for adequate wire harness access (6 inches or 15 cm) and strain relief (12 inches or 30 cm).

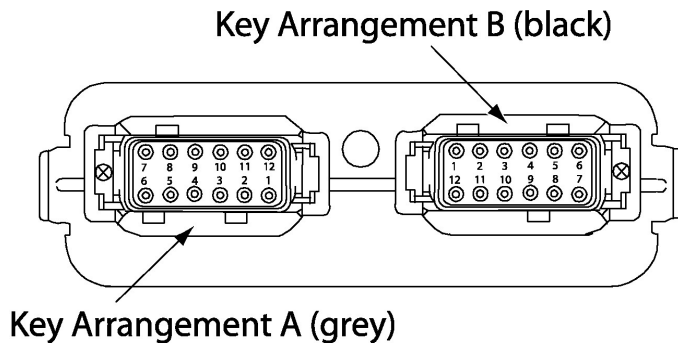

### FRONT VIEW 24 PIN RECEPTACLE

Notes: Electronic Assistant® is a registered U.S. trade mark of Axiomatic Technologies Corporation.  
Simulink® is a registered trademark of The Mathworks, Inc.

Form: TDAX200000-04/09/2025