



**USER MANUAL UMAX030355**

Version 2.0.1

# **RS-232 to CAN Converter with Two Digital Inputs CAN SAE J1939**

## **USER MANUAL**

**P/N: AX030355**

## VERSION HISTORY

<b>Version</b>	<b>Date</b>	<b>Author</b>	<b>Modification</b>
1.0.0	Dec. 5, 2024	Ilona Korpelainen	Initial Draft
2.0.0	Dec. 17, 2024	Ilona Korpelainen	Updated to match new firmware version
2.0.1	Dec. 17, 2024	M Ejaz	Marketing review Updated technical specifications

## ACRONYMS

ACK	Positive Acknowledgement (from SAE J1939 standard)
BATT +/-	Battery positive (a.k.a. Vps) or Battery Negative (a.k.a. GND)
DIN	Digital Input used to measure active high or low signals
DM	Diagnostic Message (from SAE J1939 standard)
DTC	Diagnostic Trouble Code (from SAE J1939 standard)
EA	Axiomatic Electronic Assistant (A Service Tool for Axiomatic ECUs)
ECU	Electronic Control Unit (from SAE J1939 standard)
GND	Ground reference (a.k.a. BATT-)
I/O	Inputs and Outputs
MAP	Memory Access Protocol
NAK	Negative Acknowledgement (from SAE J1939 standard)
NFC	Near Field Communication
PDU1	A format for messages that are to be sent to a destination address, either specific or global (from SAE J1939 standard)
PDU2	A format used to send information that has been labeled using the Group Extension technique and does not contain a destination address.
PGN	Parameter Group Number (from SAE J1939 standard)
PropA	Message that uses the Proprietary A PGN for peer-to-peer communication
PropB	Message that uses a Proprietary B PGN for broadcast communication
PWM	Pulse Width Modulation
RPM	Rotations per Minute
SPN	Suspect Parameter Number (from SAE J1939 standard)
TP	Transport Protocol
UIN	Universal input used to measure voltage, current, frequency or digital inputs
Vps	Voltage Power Supply (a.k.a. BATT+)
%dc	Percent Duty Cycle (Measured from a PWM input)

# TABLE OF CONTENTS

<b>1. OVERVIEW OF CONTROLLER</b> .....	<b>8</b>
1.1. CAN Frame Forwarding.....	9
1.1.1. CAN interface configuration.....	9
1.1.2. CAN Filters .....	9
1.1.3. CAN Frame Forwarding Rule sets.....	10
1.2. RS-232 Frame Forwarding .....	11
1.2.1. RS-232 interface configuration .....	11
1.2.2. RS-232 Frame Format.....	11
1.2.3. RS-232 Frame Forwarding Rule sets .....	12
1.3. Input Function Blocks .....	13
1.4. Input Filtering .....	14
1.5. CAN Transmit Message Function Block.....	15
1.5.1. CAN Transmit Message Setpoints .....	15
1.5.2. CAN Transmit Signal Setpoints .....	16
1.6. CAN Receive Function Block .....	16
1.7. Available Control Sources .....	17
1.8. Enable Control .....	17
<b>2. INSTALLATION INSTRUCTIONS</b> .....	<b>18</b>
2.1. Dimensions and Pinout.....	18
<b>3. OVERVIEW OF J1939 FEATURES</b> .....	<b>19</b>
3.1. Introduction to Supported Messages.....	19
3.2. NAME, Address and Identification Information.....	20
<b>4. ECU SETPOINTS ACCESSED WITH THE AXIOMATIC ELECTRONIC ASSISTANT</b> .....	<b>22</b>
4.1. J1939 Network Parameters .....	22
4.2. CAN interface Setpoints .....	23
4.3. CAN Filter Setpoints .....	24
4.4. CAN Frame Forward Setpoints .....	25
4.5. RS-232 Interface Setpoints .....	26
4.6. RS-232 Frame forward Setpoints .....	28
4.7. Input Setpoints.....	30
4.8. CAN Transmit Setpoints .....	31
4.9. CAN Receive Setpoints .....	33
<b>5. REFLASHING OVER CAN WITH EA BOOTLOADER</b> .....	<b>34</b>
<b>APPENDIX A - TECHNICAL SPECIFICATION</b> .....	<b>A-1</b>

Table 1 – Supported baud rate Options .....	9
Table 2 – Extended ID configuration Options.....	9
Table 3 – Frame forward rule Enable Options .....	10
Table 4 – CAN Frame Forward CAN ID Type Options.....	10
Table 5 – CAN Frame Forward RTR bit type Options.....	10
Table 6 –CAN Frame Forward bytes selection Options .....	10
Table 7 – CAN Frame Forward Output Options .....	10
Table 8 – RS232 Data bits Options .....	11
Table 9 – RS232 Parity Options .....	11
Table 10 – RS232 Stop bits Options .....	11
Table 11 – ID Field Length Options.....	11
Table 12 – RS232 Frame Forward all data bytes Options .....	12
Table 13 – RS232 Frame Forward Output Options.....	12
Table 14 – RS232 Frame Forward CAN ID Type Options .....	12
Table 15 – Input Sensor Type Options.....	13
Table 16 – Debounce Time Options.....	13
Table 17 – Software Debounce Filter Times .....	13
Table 18 – Pullup/Pulldown Resistor Options .....	14
Table 19 – Active High/Low Options .....	14
Table 20 – Digital Input Sensor Type versus Input State .....	14
Table 21 – Filter Type Options .....	14
Table 22 – CAN Transmit Data Type Options.....	16
Table 23 – Available Control Sources and Numbers .....	17
Table 24 – AX030355 Connector Pinout.....	18
Table 25 – J1939 Network Setpoints.....	22
Table 26 – CAN1 interface configuration Setpoints .....	23
Table 27 – CAN2 interface configuration Setpoints .....	23
Table 28 – CAN Filter Setpoints .....	24
Table 29 – CAN Frame Forward Setpoints .....	25
Table 30 – RS-232 interface Setpoints .....	27
Table 31 – RS-232 Frame forward Setpoints.....	29
Table 32 – Input Setpoints.....	30
Table 33 – CAN Transmit Message Setpoints .....	32
Table 34 – Input Setpoints.....	33

Figure 1 – AX030355 Block Diagram ..... 8

Figure 2 – AX030355 Dimensional Drawing ..... 18

Figure 3 – Screen Capture of J1939 Setpoints ..... 22

Figure 4 – Screen Capture of CAN1 interface configuration Setpoints ..... 23

Figure 5 – Screen Capture of CAN2 interface configuration Setpoints ..... 23

Figure 6 – Screen Capture CAN Filter Setpoints ..... 24

Figure 7 – Screen Capture of CAN Frame Forward Setpoints ..... 25

Figure 8 – Screen Capture of RS-232 interface Setpoints ..... 26

Figure 9 – Screen RS-232 Frame forward Setpoints ..... 28

Figure 10 – Screen Capture of Input Setpoints ..... 30

Figure 11 – Screen Capture of CAN Transmit Message Setpoints ..... 31

Figure 12 – Screen Capture of Input Setpoints ..... 33

## REFERENCES

J1939	Recommended Practice for a Serial Control and Communications Vehicle Network, SAE, February 2010
J1939/21	Data Link Layer, SAE, December 2006
J1939/71	Vehicle Application Layer, SAE, March 2011
J1939/73	Application Layer-Diagnostics, SAE, February 2010
J1939/81	Network Management, SAE, March 2017
TDAX030355	Technical Datasheet, Axiomatic Technologies
UMAX07050x	User Manual, Axiomatic Electronic Assistant and USB-CAN, Axiomatic Technologies

***This document assumes the reader is familiar with the SAE J1939 standard. Terminology from the standard is used, but not described in this document.***



NOTE: This product is supported by Axiomatic Electronic Assistant **VX.XX.XX** and higher.

# 1. OVERVIEW OF CONTROLLER

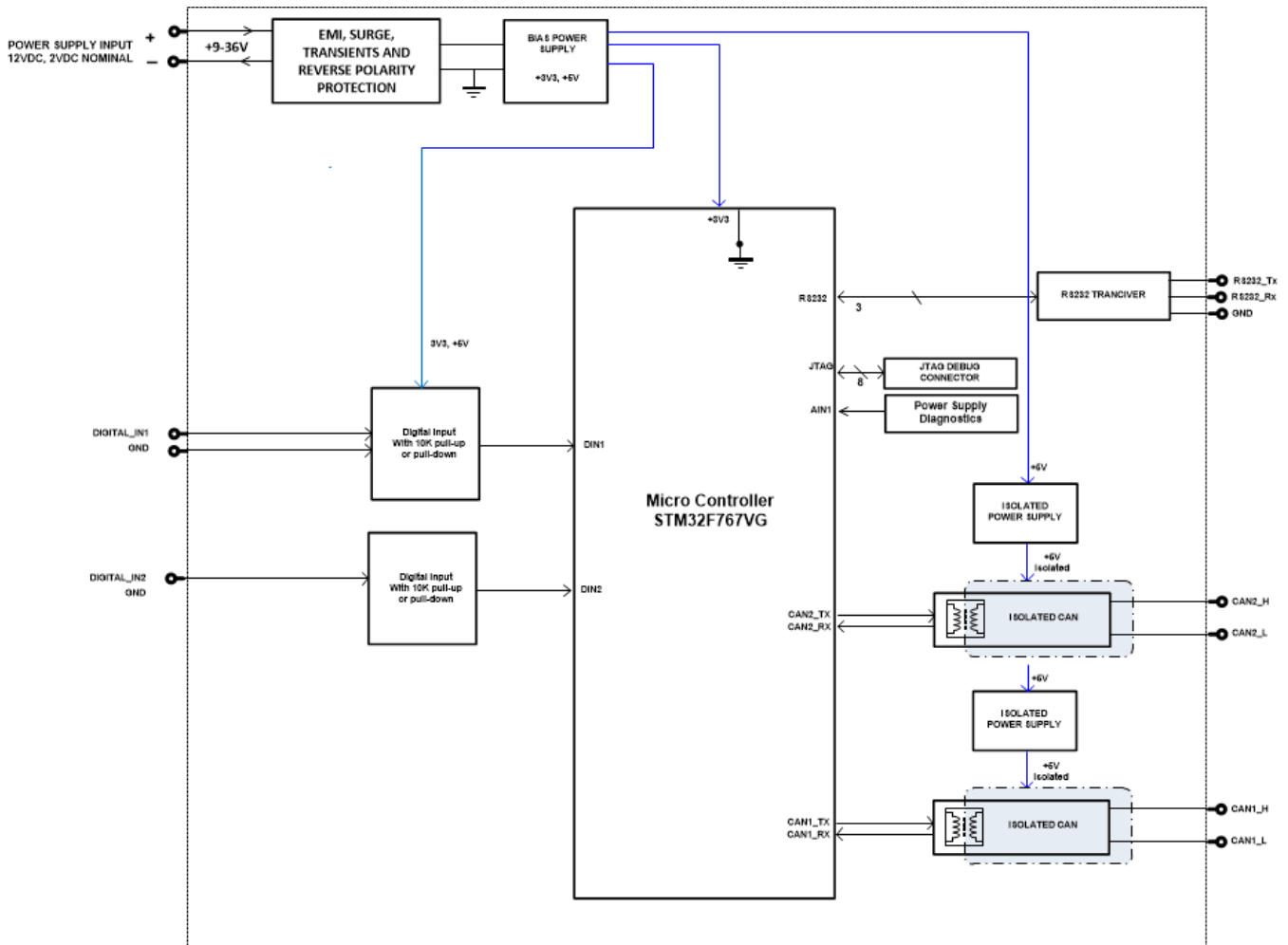

**Figure 1 – AX030355 Block Diagram**

The RS-232 to CAN Converter with Two Digital Inputs (2DIN-2CAN-RS-232) is a compact device for interfacing RS-232 satellite phones or GPS systems with CAN bus in on-road commercial vehicles.

The RS-232 serial port interface is provided with user configurable frame forwarding system to convert serial port messages into can frames. Likewise, the two fully isolated CAN interfaces have user configurable CAN ID filtering and frame forward system, to convert CAN frames into serial port messages. By default, the primary CAN port (CAN1) supports J1939 messaging and uses passive baud rate discovery to detect CAN network baud rate.

In addition, two digital signal inputs are provided. The inputs can be configured to measure frequency, PWM and digital signals. Measured input data can be sent to a SAE J1939 CAN Network or used to enable/disable frame forwarding.



A *Windows*-based Axiomatic Electronic Assistant (EA) is used to configure the controller via an USB-CAN (AX070501) device. Configurable properties, EA setpoints, are outlined in chapter 4. Setpoint configuration can be saved in a file which can be used to easily program the same configuration into another 2DIN-2CAN-RS-232. Throughout this document EA setpoint names are referred to with bolded text in double-quotes and the setpoint option is referred with italicized text in single-quotes. For example, “**Input Sensor Type**” setpoint set to option ‘*Frequency 0.5 to 50 Hz*’.

The configurable settings and functionality of 2DIN-2CAN-RS-232 is discussed in the next subchapters.

## 1.1. CAN Frame Forwarding

2DIN-2CAN-RS-232 is provided with two CAN ports. CAN1 is configured to support J1939 messaging and can be used to configure the controller with EA. However, both CAN interfaces can be configured to forward message frames.

### 1.1.1. CAN interface configuration

By default, CAN1 uses passive baud rate scan to detect J1939 network baud rate. The detected baud rate is stored as a default baud rate in non-volatile memory and used as a starting point at the next start up. If the CAN1 port is going to be connected to network without continuous communication, it is advisable to disable baud rate scan. The baud rate for CAN2 interface is user selectable through EA setpoint. The default baud rate for CAN2 is 250kbps.

0	<i>1000 kbps</i>
1	<i>667 kbps</i>
2	<i>500 kbps</i>
3	<i>250 kbps</i>
4	<i>125 kbps</i>
5	<i>100 kbps</i>

**Table 1 – Supported baud rate Options**

### 1.1.2. CAN Filters

Four user configurable CAN ID filters are available for each CAN interface. To ensure EA communication, three of the CAN1 Filters are preconfigured to accept J1939 frames and cannot be reconfigured by user. By default, the CAN2 does not accept any messages.

The “**Filter ID**” defines the 29-bit or 11-bit standard CAN frame ID. The “**Filter Mask**” bit ‘1’ forces the compare and the ‘0’ marks the bit as ‘don’t care’. When a filter is enabled, the configured Filter ID will be assigned to the CAN interface acceptance filter. The extended ID bit of the acceptance mask can be configured with “**Extended ID configuration**” setpoint.

0	<i>ExtID</i>
1	<i>StdID</i>
2	<i>Don’t care</i>

**Table 2 – Extended ID configuration Options**

For receiving all frames (i.e., no filtering), “**Filter ID**” and “**Filter Mask**” should be configured to 0x0 and Extended ID configuration set as ‘*don’t care*’.

### 1.1.3. CAN Frame Forwarding Rule sets

The received messages can be forwarded through the frame forwarding system by configuring frame forward settings with the EA. There are eight individual frame forwarding rule sets for each CAN interface.

It is possible to configure Frame forward to be enabled depending on measured value of an input by selecting suitable “**Enable Source**” and “**Enable Number**” values. By default, forward rule sets are always enabled.

Frames can be further filtered by configuring “**Match ID**” and “**Match ID Mask**”, “**CAN ID type**” and “**RTR bit type**” setpoints. The forward rule must be enabled by selecting suitable option for “**Forward rule enable**”.

0	<i>Disabled</i>
1	<i>Enabled and filtering</i>
2	<i>Enabled, no filtering</i>

**Table 3 – Frame forward rule Enable Options**

0	<i>ExtID</i>
1	<i>StdID</i>
2	<i>Don’t care</i>

**Table 4 – CAN Frame Forward CAN ID Type Options**

0	<i>Bit set</i>
1	<i>Bit Cleared</i>
2	<i>Don’t care</i>

**Table 5 – CAN Frame Forward RTR bit type Options**

Each frame forward has three selectable outputs where the frame data can be routed. Output options are CAN1, CAN2 and RS-232. It is possible to limit the number of forwarded bytes with “**Forward bytes selection**” and “**Number of data bytes to forward**” setpoints. Options 3 and 4 will include CAN frame ID in the message when forwarded to the RS-232 port.

0	<i>Forward all data bytes</i>
1	<i>Forward specific number of data bytes</i>
2	<i>Forward full message</i>
3	<i>Forward CAN ID (RS232) + all data bytes</i>
4	<i>Forward CAN ID (RS232) + specific number of data bytes</i>

**Table 6 –CAN Frame Forward bytes selection Options**

0	<i>CAN1</i>
1	<i>CAN2</i>
2	<i>RS-232</i>

**Table 7 – CAN Frame Forward Output Options**

The original CAN ID can be replaced by configuring “**Enable data replacing**”, “**Replace ID filter**” and “**Replace ID Mask**”. Message data is forwarded to the RS-232 port directly, so each data byte produces corresponding ASCII character at the serial port.

## 1.2. RS-232 Frame Forwarding

### 1.2.1. RS-232 interface configuration

User configurable serial port parameters contain freely settable baud rate, number of data, start and stop bits. Parity bit option is available for RS-232 transmits, however RS-232 receive does not check frame parity. When receiving messages detected idle condition is considered as message delimiter. In addition, a continuous serial stream can be separated into messages by configuring the special delimiter character to be used. Value of the “Delimiter character” setpoint present the character ASCII value in hexadecimal.

0	<i>7-bits</i>
1	<i>8-bits</i>

**Table 8 – RS232 Data bits Options**

0	<i>None</i>
1	<i>Odd</i>
2	<i>Even</i>

**Table 9 – RS232 Parity Options**

0	<i>0.5 bit</i>
1	<i>1 bit</i>
2	<i>1.5 bit</i>
3	<i>2 bits</i>

**Table 10 – RS232 Stop bits Options**

### 1.2.2. RS-232 Frame Format

The format of frames forwarded from CAN to RS-232 can be configured to suit RS-232 receiver end needs with setpoints under “RS232 interface” setpoint group. If needed, the frame message data can be converted into ASCII characters by setting “**Convert data to ASCII**” to ‘*True*’. With this setting, it is possible to produce easily readable frames, for example to serial terminal applications. Up to four start and end bytes can be configured to denote start and end of the RS-232 frame. When CAN frame forward is configured to add CANID at the beginning of frame data, the ID field length can be selected with “**ID Field Length**” setpoint.

0	<i>CAN Frame ID length</i>
1	<i>4 byte ID</i>
2	<i>2 byte ID</i>
3	<i>PGN bytes</i>

**Table 11 – ID Field Length Options**

With “**Add delimiter between ID and Data fields**” and “**ID – Data field delimiter**” setpoints, it is possible to define a character that separates ID and Data fields. If the frame is not configured to contain CAN ID, the ID – Data delimiter character can be utilized as fifth start byte. In addition, the data length of the received CAN message can be placed in first byte of Data field.

### 1.2.3. RS-232 Frame Forwarding Rule sets

It is possible to configure Frame forward to be enabled depending on measured values of an input by selecting suitable “**Enable Source**” and “**Enable Number**” values. By default, forward rule sets are always enabled.

There are three Frame forward rule sets available for the RS-232 interface. The messages can be filtered with “**Match filter**” and “**Mask filter**” settings. Eight-byte “**Match filter**” contains ASCII values of filter characters in hexadecimal form. “**Mask filter**” bit ‘1’ forces compare and ‘0’ marks the bit ‘don’t care’. Messages satisfying mask and match equation, will be forwarded. If no filtering is needed the “**Mask filter**” can be set to the default value of all zeros.

It is possible to add up to four configured bytes to both end and start of the message. Number of the forwarded data bytes can be limited with “**Forward all data bytes**” and “**Number of data bytes to forward**” setpoints. The maximum length of the message is 128 bytes.

0	<i>Forward all data bytes</i>
1	<i>Forward specific number of data bytes</i>

**Table 12 – RS232 Frame Forward all data bytes Options**

Each frame forward has three selectable outputs where to frame data can be routed. Output options are CAN1, CAN2 and RS-232.

0	<i>CAN1</i>
1	<i>CAN2</i>
2	<i>RS-232</i>

**Table 13 – RS232 Frame Forward Output Options**

When CAN port is selected as an output option, the “**CAN ID type**” setpoint determines type of used CAN frame ID. By default, the first 28/11 bits of the message will be used as CAN frame ID. Alternatively, CAN frame ID defined with “**CAN ID**” setpoint can be used, by setting “**Add CAN Frame ID**” setpoint to True.

0	<i>ExtID</i>
1	<i>StdID</i>

**Table 14 – RS232 Frame Forward CAN ID Type Options**

When the frame data exceeds 8 bytes, it will be, by default, sent as multiple single CAN frames. The frame index can be added to CAN frame byte 0, to form transport protocol like output. For CAN1 output, it is also possible to enable multipacket transport protocol for the frames with data exceeding 8 bytes. This requires that a 29-bit CAN ID is defined for the messages.

### 1.3. Input Function Blocks

The controller has two digital signal inputs, that can be configured to measure frequency, PWM or digital signal.

Input setpoint group has the “**Input Sensor Type**” setpoint, which is used to configure input type. Selecting input type effects on other setpoints and how they are interpreted and should thus be selected first on this block. All available input sensor types are listed in Table 15.

0	<i>Disabled</i>
40	<i>Frequency 0.5 to 50 Hz</i>
41	<i>Frequency 10 Hz to 1 kHz</i>
42	<i>Frequency 100 Hz to 10 kHz</i>
50	<i>PWM Low Frequency (&lt;1kHz)</i>
51	<i>PWM High Frequency (&gt;100Hz)</i>
60	<i>Digital (normal)</i>
61	<i>Digital (inverse)</i>
62	<i>Digital (latched)</i>

**Table 15 – Input Sensor Type Options**

Values of “**Minimum Range**” and “**Maximum Range**” setpoints define ON/OFF thresholds for an enable signal, when Input configured as an Enable Source for a frame forward rule.

Frequency/RPM or Pulse Width Modulated (PWM) “**Input Sensor Type**” options connect an input to 16-bit timer pin on the processor. “**Debounce Time**” setpoint is used to select an input capture filter for the timer pin in question. “**Pulse Per Revolution**” setpoint is only associated with the frequency input type. If the setpoint is set to *True*, then the input data will be reported as in rotations-per-minute (RPM). Otherwise, frequency inputs are measured in Hertz.

0	<i>None</i>
1	<i>111ns</i>
2	<i>1.78us</i>
3	<i>14.22us</i>

**Table 16 – Debounce Time Options**

An additional software debounce filter can be used with Digital Input types for filtering the inputs using longer time constants than with the default debounce filter. The available software implemented debounce times are listed in Table 17.

0	<i>0ms</i>
1	<i>10ms</i>
2	<i>20ms</i>
3	<i>40ms</i>
4	<i>100ms</i>
5	<i>200ms</i>
6	<i>400ms</i>
7	<i>1000ms</i>

**Table 17 – Software Debounce Filter Times**

Digital Inputs have available three Digital “**Input Sensor Type**” options: Normal, Inverse and Latched. With digital input sensor types, the input measurement is given, either 1 (ON) or 0 (OFF).

On Frequency, PWM and digital input modes 10kΩ pull-up or pull-down resistors can be enabled or disabled by setting the value of the “**Pullup/Pulldown Resistor**” setpoint. Setpoint options are given in Table 18. By default, pull-down resistors are enabled for both inputs.

0	10 kΩ Pulldown
1	10 kΩ Pullup

**Table 18 – Pullup/Pulldown Resistor Options**

“**Active High/Active Low**” setpoint is used to configure how signal high and low are interpreted. Setpoint options are given in Table 19. By default, all inputs are selected to be Active High, which means that signal high is interpreted as 1(ON) and signal low as 0(OFF).

0	Active High
1	Active Low

**Table 19 – Active High/Low Options**

Table 20 shows the effect of different digital input types on input signal measurement interpretation with recommended “**Pullup/Pulldown Resistor**” and “**Active High/Low**” combinations. Fault diagnostics are not available for digital input types.

Input Sensor Type		Pulldown Active High	Pullup Active Low	Input measured (state)
6	<i>Digital (normal)</i>	High	Low or Open	1 (ON)
		Low or Open	High	0 (OFF)
61	<i>Digital (inverse)</i>	High or Open	Low	1 (ON)
		Low	High or Open	0 (OFF)
62	<i>Digital (latched)</i>	High to Low	Low to High	0 (no change)
		Low to High	High to Low	1 (state change)

**Table 20 – Digital Input Sensor Type versus Input State**

Software filters can be applied to the measured input signal. Setpoints “**Software Filter Type**” and “**Software Filter Constant**” are used to configure the software filter. By default, no filter is applied to the signal. Software filtering is described in detail in section below.

#### 1.4. Input Filtering

Measured input data from universal inputs can be filtered to form desired CAN message data. Input filters are configured with “**Filter Type**” and “**Filter Constant**” setpoints. Filters are configured for each input individually.

0	No Filtering
1	Moving Average
2	Repeating Average

**Table 21 – Filter Type Options**

“**Filter Type**” setpoint defines the type of software filter used. Setpoint options are ‘*No Filtering*’, ‘*Moving Average*’ and ‘*Repeating Average*’. The ‘*No Filtering*’ option applies no filtering to the measured input data. The ‘*Moving Average*’ option applies the transfer function below to the measured input data, where  $Value_N$  is the current value of the CAN message data,  $Value_{N-1}$  is the previous CAN message data and Filter Constant is the value of the “**Filter Constant setpoint**”.

Equation 1 - Moving Average Transfer Function:

$$Value_N = Value_{N-1} + \frac{(Input - Value_{N-1})}{Filter\ Constant}$$

Equation 2 - Repeating Average Transfer Function:

$$Value = \frac{\sum_0^N Input_N}{N}$$

The ‘*Repeating Average*’ option applies the transfer function above to the measured input data, where N is value of the “**Filter Constant**” setpoint. At every reading of the input value, the value is added to the sum. At every N<sup>th</sup> read, the sum is divided by N, and the result is new CAN message data. The sum is set to zero for the next read and summing is started again.

## 1.5. CAN Transmit Message Function Block

The CAN Transmit function block is used to send measured signal input value to the J1939 network (CAN1). The AX030355 ECU has two CAN Transmit Messages, and each message has four completely user defined signals.

### 1.5.1. CAN Transmit Message Setpoints

Each CAN Transmit Message setpoint group includes setpoints that affect the whole message and are thus mutual for all signals of the message. These setpoints are presented in this section. The setpoints that configure an individual signal are presented in the next section.

The “**Transmit PGN**” setpoint sets PGN used with the message. **User should be familiar with the SAE J1939 standard and select values for PGN/SPN combinations as appropriate from section J1939/71.**

“**Repetition Rate**” setpoint defines the interval used to send the message to the J1939 network. If the “**Repetition Rate**” is set to zero, the message is disabled unless it shares its PGN with another message. In the case of a shared PGN repetition rate of the LOWEST numbered message are used to send the message ‘bundle’.



At power-up, transmitted message will not be broadcasted until after a 5 second delay. This is done to prevent any power up or initialization conditions from creating problems on the network.

By default, all messages are sent on Proprietary B PGNs as broadcast messages. Thus “**Transmit Message Priority**” is always initialized to 6 (low priority) and the “**Destination Address**” setpoint is not used. This setpoint is only valid when a PDU1 PGN has been selected, and it can be set either to the Global Address (0xFF) for broadcasts or sent to a specific address as setup by the user.

### 1.5.2. CAN Transmit Signal Setpoints

Each CAN transmit message has four associated signals, which define data inside the Transmit message. “**Control Source**” setpoint together with “**Control Number**” setpoint define the signal source of the message. “**Control Source**” and “**Control Number**” options are listed in Table 23. Setting “**Control Source**” to ‘*Control Not Used*’ disables the signal.

“**Transmit Data Type**” setpoint options are listed in Table 22. By default, ‘*CAN signal continuous*’ is selected and signal data is presented in continuous form. If ‘*CAN signal discrete*’ the signal data is considered as digital and is interpreted as 0 or 1. When ‘*CAN signal undefined*’ signal data is considered undefined, and all signal bits are set to 1.

0	<i>CAN signal undefined</i>
1	<i>CAN signal discrete</i>
2	<i>CAN signal continuous</i>

**Table 22 – CAN Transmit Data Type Options**

“**Transmit Data Width**” setpoint determines how many bits signal reserves from the message. “**Transmit Data Index in Array**” determines in which of 8 bytes of the CAN message LSB of the signal is located. Similarly, “**Transmit Bit Index in Byte**” determines in which of 8 bits of a byte the LSB is located. These setpoints are freely configurable, thus **it is the User’s responsibility to ensure that signals do not overlap and mask each other.**

For continuous signal, “**Transmit Data Resolution**” setpoint determines the scaling done on the signal data before it is sent to the bus. “**Transmit Data Offset**” setpoint determines the value that is subtracted from the signal data before it is scaled.

### 1.6. CAN Receive Function Block

The CAN Receive function block is designed to take any SPN from the J1939 network (CAN1) and use it as an input to another function block (i.e. Outputs).

The “**Receive Message Enabled**” is the most important setpoint associated with this function block and it should be selected first. Changing it will result in other setpoints being enabled/disabled as appropriate. By default, ALL receive messages are disabled.

Once a message has been enabled, a Lost Communication fault will be flagged if that message is not received off the bud within the “**Receive Message Timeout**” period.

By default, all control messages are expected to be sent to the 2DIN-2CAN-RS-232 on Proprietary B PGNs. PDU1 messages to ECU address, from other than Global Address (0xFF) are accepted. Messages can be filtered according to sender address by configuring “**Address that Sends**” to true and setting “**Specific Address that sends**” to desired address value.



The “**Receive Data Type**”, “**Receive Data Width**”, “**Receive Data Index in Array (LSB)**”, “**Receive Bit Index in Byte (LSB)**”, “**Receive Resolution**” and “**Receive Offset**” can all be used to map any SPN supported by the J1939 standard to the output data of the Received function block.

Values of “**Receive DATA OFF Threshold**” and “**Receive DATA ON Threshold**” setpoints define ON/OFF thresholds for an enable signal, when Can Receive is configured as an Enable Source for a frame forward rule.

The 2DIN-2CAN-RS-232 supports up to two unique CAN Receive Messages. Defaults setpoint values are listed in Section 4.8.

### 1.7. Available Control Sources

Some Function Blocks have selectable input signals, which are determined with “[**Name**] **Source**” and “[**Name**] **Number**” setpoints. Together, these setpoints uniquely select how the I/O of the various function blocks are linked together. “[**Name**] **Source**” setpoint determines the type of the source and “[**Name**] **Number**” selects the actual source if there is more than one of the same types. Available “[**Name**] **Source**” options and associated “[**Name**] **Number**” ranges are listed in Table 23. Though input Sources are freely selectable, not all options would make sense for any input, and it is up to the user to program the controller in a logical and functional manner.

Sources	Number Range	Notes
<i>0: Control Not Used</i>	N/A	When this is selected, it disables all other setpoints associated with the signal in question.
<i>1: Received CAN Message</i>	1 to 2	1 – CAN Receive 1 2 – CAN Receive 2
<i>2: Input Measured</i>	1 to 2	1 – Digital Signal Input1 2 – Digital Signal Input2

**Table 23 – Available Control Sources and Numbers**

### 1.8. Enable Control

CAN frame forward rules as well as RS232 frame forward rules can be configured to be enabled and disabled depending on value of selected enable source. Enable signal is an ON/OFF signal. When *Input Measured* is selected as an “**Enable Source**”, the input minimum and maximum range values define ON and OFF thresholds of the enable signal. Similarly, when *Received CAN Message* is selected as enable source the “**Receive Data OFF Threshold**” and “**Receive Data ON Threshold**” values, are used as enable signal thresholds.

## 2. INSTALLATION INSTRUCTIONS

### 2.1. Dimensions and Pinout

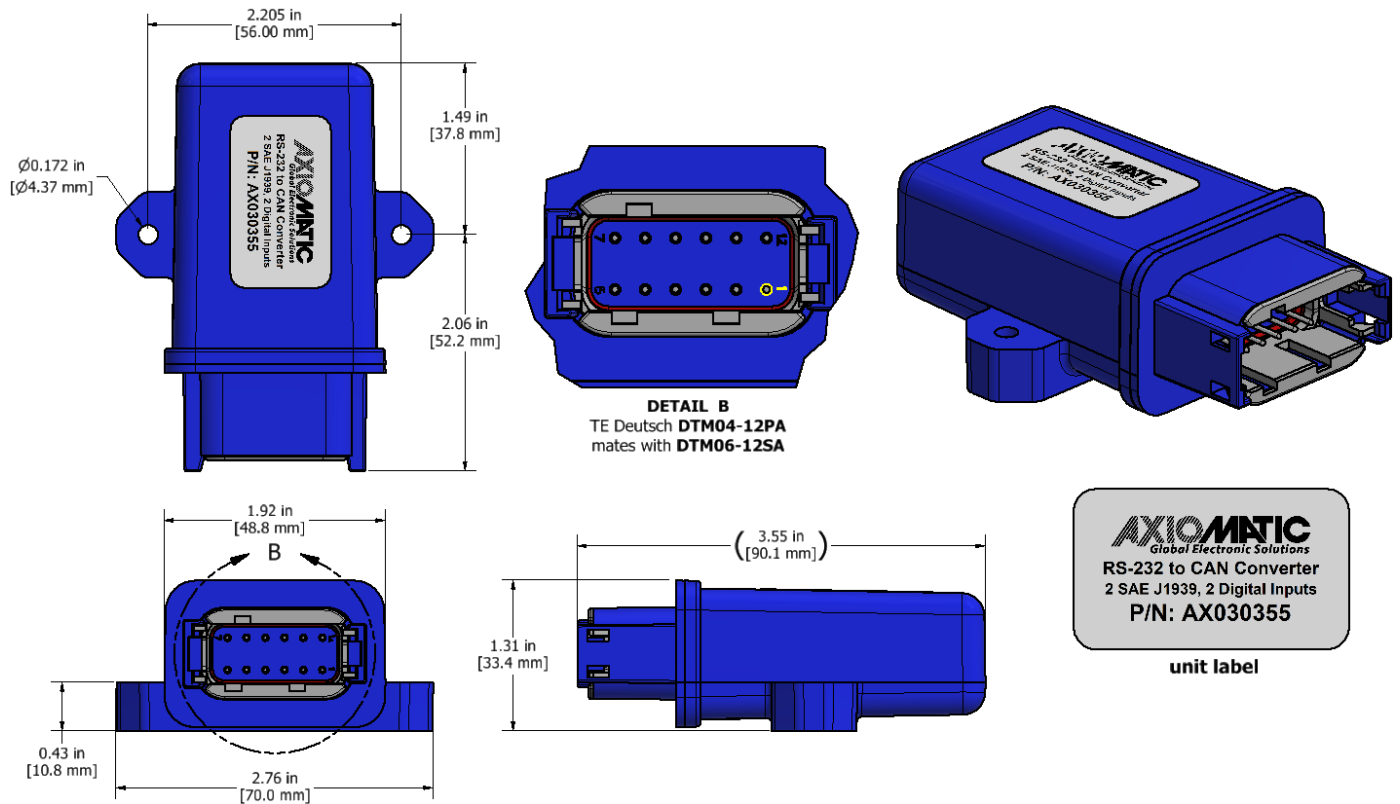

Figure 2 – AX030355 Dimensional Drawing

Pin	Function	Pin	Function
1	Battery -	12	Battery +
2	CAN 2 H	11	CAN 2 Shield
3	CAN 2 L	10	Ground
4	RS-232 Rx	9	Digital Input 2
5	RS-232 Tx	8	Digital Input 1
6	CAN 1 H	7	CAN 1 L

Table 24 – AX030355 Connector Pinout

### 3. OVERVIEW OF J1939 FEATURES

---

The software was designed to provide flexibility to the user with respect to messages sent from the ECU by providing:

- Configurable ECU Instance in the NAME (to allow multiple ECUs on the same network)
- Configurable Input Parameters
- Configurable PGN and Data Parameters
- Configurable Diagnostic Messaging Parameters, as required
- Diagnostic Log, maintained in non-volatile memory

#### 3.1. Introduction to Supported Messages

The ECU is compliant with the standard SAE J1939 and supports following PGNs from the standard.

##### From J1939-21 – Data Link Layer

- |  |            |          |
|--|------------|----------|
| • Request                                    | 59904      | 0x00EA00 |
| • Acknowledgement                            | 59392      | 0x00E800 |
| • Transport Protocol – Connection Management | 60416      | 0x00EC00 |
| • Transport Protocol – Data Transfer Message | 60160      | 0x00EB00 |
| • Proprietary B                              | from 65280 | 0x00FF00 |
|  | to 65535   | 0x00FFFF |

##### From J1939-73 – Diagnostics

- |  |       |          |
|--|-------|----------|
| • DM1 – Active Diagnostic Trouble Codes                        | 65226 | 0x00FECA |
| • DM2 – Previously Active Diagnostic Trouble Codes             | 65227 | 0x00FECB |
| • DM3 – Diagnostic Data Clear/Reset for Previously Active DTCs | 65228 | 0x00FECC |
| • DM11 – Diagnostic Data Clear/Reset for Active DTCs           | 65235 | 0x00FED3 |
| • DM14 – Memory Access Request                                 | 55552 | 0x00D900 |
| • DM15 – Memory Access Response                                | 55296 | 0x00D800 |
| • DM16 – Binary Data Transfer                                  | 55040 | 0x00D700 |

##### From J1939-81 – Network Management

- |                                |       |          |
|--------------------------------|-------|----------|
| • Address Claimed/Cannot Claim | 60928 | 0x00EE00 |
| • Commanded Address            | 65240 | 0x00FED8 |

##### From J1939-71 – Vehicle Application Layer

- |                           |       |          |
|---------------------------|-------|----------|
| • Software Identification | 65242 | 0x00FEDA |
|---------------------------|-------|----------|

None of the application layer PGNs are supported as part of the default configurations, but they can be selected as desired for transmit function blocks.

Setpoints are accessed using standard Memory Access Protocol (MAP) with proprietary addresses. The Axiomatic Electronic Assistant (EA) allows for quick and easy configuration of the unit over CAN network.

### 3.2. NAME, Address and Identification Information

The 2DIN-2CAN-RS-232 I/O ECU has the following default for the J1939 NAME. The user should refer to the SAE J1939/81 standard for more information on these parameters and their ranges.

Arbitrary Address Capable	Yes
Industry Group	0, Global
Vehicle System Instance	0
Vehicle System	0, Non-specific system
Function	89, Network Interconnect ECU
Function Instance	3, Axiomatic AX030355
ECU Instance	0, First Instance
Manufacture Code	162, Axiomatic Technologies
Identity Number	Variable, uniquely assigned during factory programming for each ECU

The ECU Instance is a configurable setpoint associated with the NAME. Changing this value will allow multiple ECUs of this type to be distinguishable from one another when they are connected on the same network.

The default value of the “ECU Address” setpoint is 128 (0x80), which is the preferred starting address for self-configurable ECUs as set by the SAE in J1939 tables B3 and B7. The EA will allow the selection of any address between 0 and 253. ***It is user’s responsibility to select an address that complies with the standard.*** The user must also be aware that since the unit is arbitrary address capable, if another ECU with a higher priority NAME contends for the selected address, the 2DIN-2CAN-RS-232 I/O will continue select the next highest address until it finds one that it can claim. See J1939/81 for more details about address claiming.

#### ECU Identification Information

PGN 64965	ECU Identification Information		-ECUID
Transmission Repetition Rate:	On request		
Data Length:	Variable		
Extended Data Page:	0		
Data Page:	0		
PDU Format:	253		
PDU Specific:	197 PGN Supporting Information:		
Default Priority:	6		
Parameter Group Number:	64965 (0x00FDC5)		
Start Position	Length	Parameter Name	SPN
a	Variable	ECU Part Number, Delimiter (ASCII “*”)	2901
b	Variable	ECU Serial Number, Delimiter (ASCII “*”)	2902
c	Variable	ECU Location, Delimiter (ASCII “*”)	2903
d	Variable	ECU Type, Delimiter (ASCII “*”)	2904
e	Variable	ECU Manufacturer Name, Delimiter (ASCII “*”)	4304
(a)*(b)*(c)*(d)*(e)*			

## Software Identifier

PGN 65242	Software Identification	- SOFT	
Transmission Repetition Rate:	On request		
Data Length:	Variable		
Extended Data Page:	0		
Data Page:	0		
PDU Format:	254		
PDU Specific:	218 PGN Supporting Information:		
Default Priority:	6		
Parameter Group Number:	65242 (0xFEDA)		
Start Position	Length	Parameter Name	SPN
1	1 Byte	Number of software identification fields	965
2-n	Variable	Software identification(s), Delimiter (ASCII “*”)	234

Byte 1 is set to 5, and the identification fields are as follows.

<b>(Part Number)*(Version)*(Date)*(Owner)*(Description)</b>
---

The EA shows all this information in “General ECU Information”, as shown below.

*Note: The information provided in the Software ID is available for any J1939 service tool which supports the PGN -SOFT.*

## Component Identification

PGN 65259	Component Identification	-CI	
Transmission Repetition Rate:	On request		
Data Length:	Variable		
Extended Data Page:	0		
Data Page:	0		
PDU Format:	254		
PDU Specific:	235 PGN Supporting Information:		
Default Priority:	6		
Parameter Group Number:	65259 (0x00FEED)		
Start Position	Length	Parameter Name	SPN
a	1-5 Byte	Make, Delimiter (ASCII “*”)	586
b	Variable	Model, Delimiter (ASCII “*”)	587
c	Variable	Serial Number, Delimiter (ASCII “*”)	588
d	Variable	Unit Number (Power Unit), Delimiter (ASCII “*”)	233
<b>(a)*(b)*(c)*(d)*(e)*</b>			

## 4. ECU SETPOINTS ACCESSED WITH THE AXIOMATIC ELECTRONIC ASSISTANT

This section describes in detail each setpoint, and their defaults and ranges. Default values presented in tables are values used when the setpoint in question is active. Many of the setpoints are dependent on other setpoints and they may not be active by default. Associated Figures show screen capture of initial operation, however some of the setpoints are not in default condition as they are set differently to activate more setpoints for the image. The setpoints are divided into setpoint groups as they are shown in EA. For more information on how each setpoint is used by 2DIN-2CAN-RS-232, refer to the relevant section in this user manual.

### 4.1. J1939 Network Parameters

“ECU Instance Number” and “ECU Address” setpoints and their effect are defined in Section 3.2.

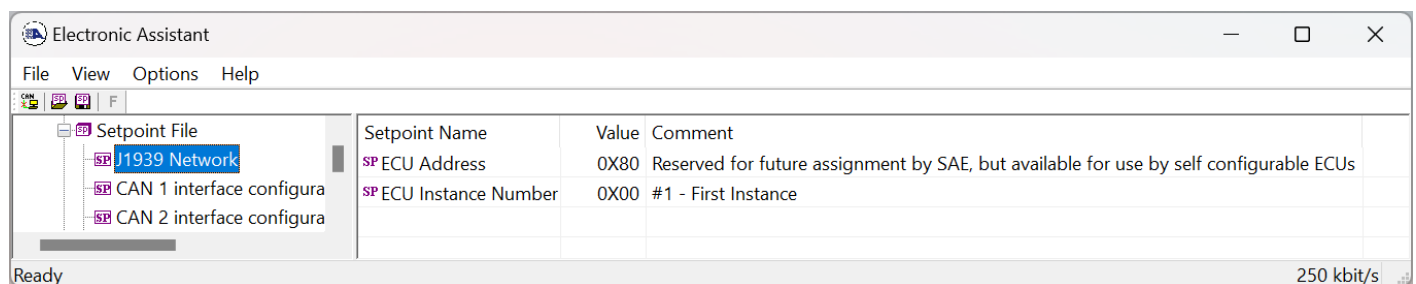

Figure 3 – Screen Capture of J1939 Setpoints

Name	Range	Default	Notes
ECU Address	0x80	0-253	Preferred address for a self-configurable ECU
ECU Instance	0-7	0x00	Per J1939-81

Table 25 – J1939 Network Setpoints

The “ECU Instance Number” or “ECU Address” are not programmable through a setpoint file. Instead these setpoint can only be programmed manually.

## 4.2. CAN interface Setpoints

CAN interface settings are defined in section 1.1.1.

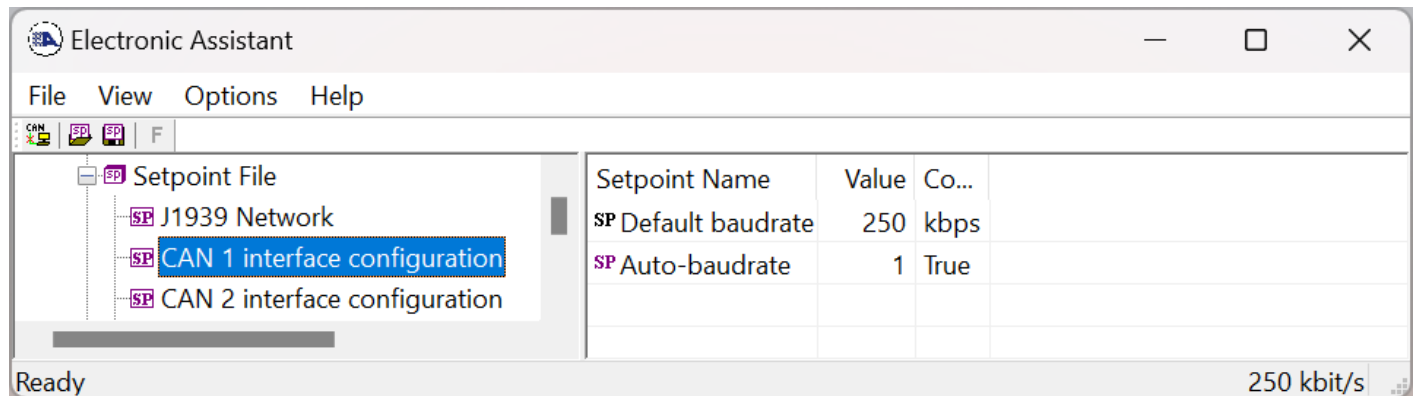

**Figure 4 – Screen Capture of CAN1 interface configuration Setpoints**

Name	Range	Default	Notes
Default baud rate	Drop List	250 kbps	Read Only Parameter
Baud rate scan enabled	False/True	1 – True	

**Table 26 – CAN1 interface configuration Setpoints**

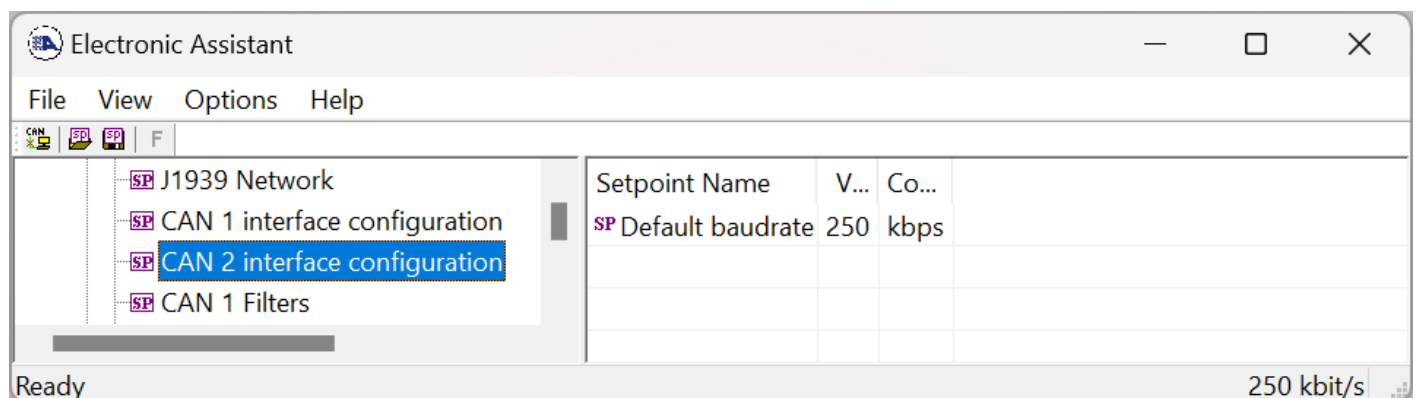

**Figure 5 – Screen Capture of CAN2 interface configuration Setpoints**

Name	Range	Default	Notes
Default baud rate	Drop List	250 kbps	See Table 1

**Table 27 – CAN2 interface configuration Setpoints**

### 4.3. CAN Filter Setpoints

CAN Filter configurations are presented in Section 1.1.1. Please refer there for detailed information about how these setpoints are used. The first three CAN1 filters are configured to enable EA communication and cannot be changed. By default, CAN2 does not accept any can frames.

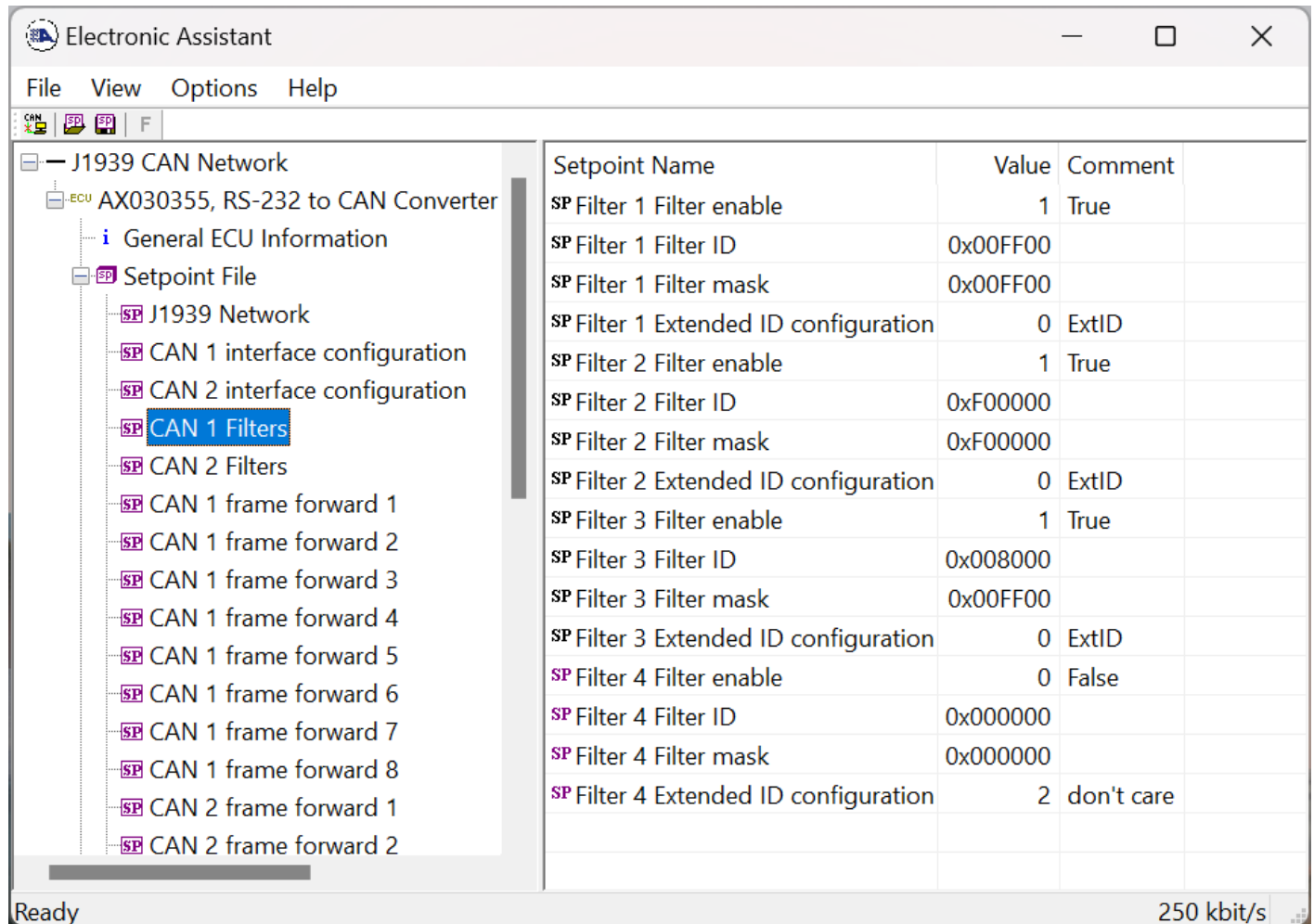

**Figure 6 – Screen Capture CAN Filter Setpoints**

Name	Range	Default	Notes
Filter Enable	True / False	False	
Filter ID	0x000000 to 0xFFFFFFFF	0	
Filter mask	0x000000 to 0xFFFFFFFF	0	
Extended ID configuration	Drop List	2 – Don't care	See Table 2

**Table 28 – CAN Filter Setpoints**



## 4.4. CAN Frame Forward Setpoints

The CAN Frame Forward is described in Section 1.1.3. Please refer there for detailed information about how these setpoints are used. Frame forwards are disabled by default. Suitable enable option and at least one output needs to be configured, to enable the frame forward rule.

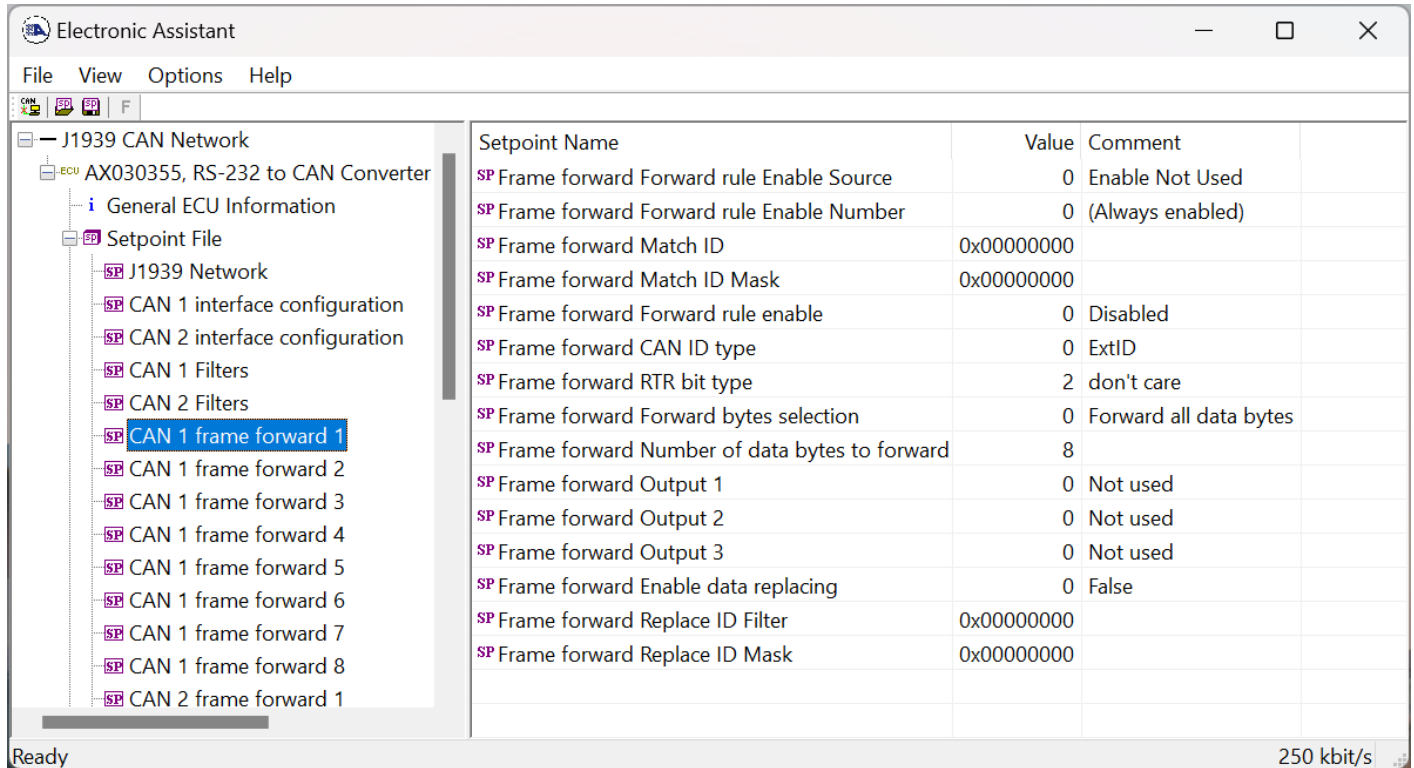

**Figure 7 – Screen Capture of CAN Frame Forward Setpoints**

Name	Range	Default	Notes
Forward rule Enable Source	Drop List	0 – Enable Not Used	See Table 23
Forward rule Enable Number	1 to 2	0 (Always enabled)	See Table 23
Match ID	0x00000000 to 0xFFFFFFFF	0	
Match ID Mask	0x00000000 to 0xFFFFFFFF	0	
Forward rule enable	Drop List	0	
CAN ID type	Drop List	0 – ExtID	See Table 4
RTR bit type	Drop List	2 – Don't care	See Table 5
Forward bytes selection	Drop List	0 – Forward all data bytes	See Table 6
Number of data bytes to forward	0 to 8	8	
Output 1	Drop List	0 – Not used	See Table 7
Output 2	Drop List	0 – Not used	See Table 7
Output 3	Drop List	0 – Not used	See Table 7
Enable data replacing	False/True	False	
Replace ID Filter	0x00000000 to 0xFFFFFFFF	0	
Replace ID Mask	0x00000000 to 0xFFFFFFFF	0	

**Table 29 – CAN Frame Forward Setpoints**

## 4.5. RS-232 Interface Setpoints

RS-232 interface setpoints are used to configure the RS-232 interface and SR-232 frame format. This functionality is explained in more detail in sections 1.2.1 and 1.2.2

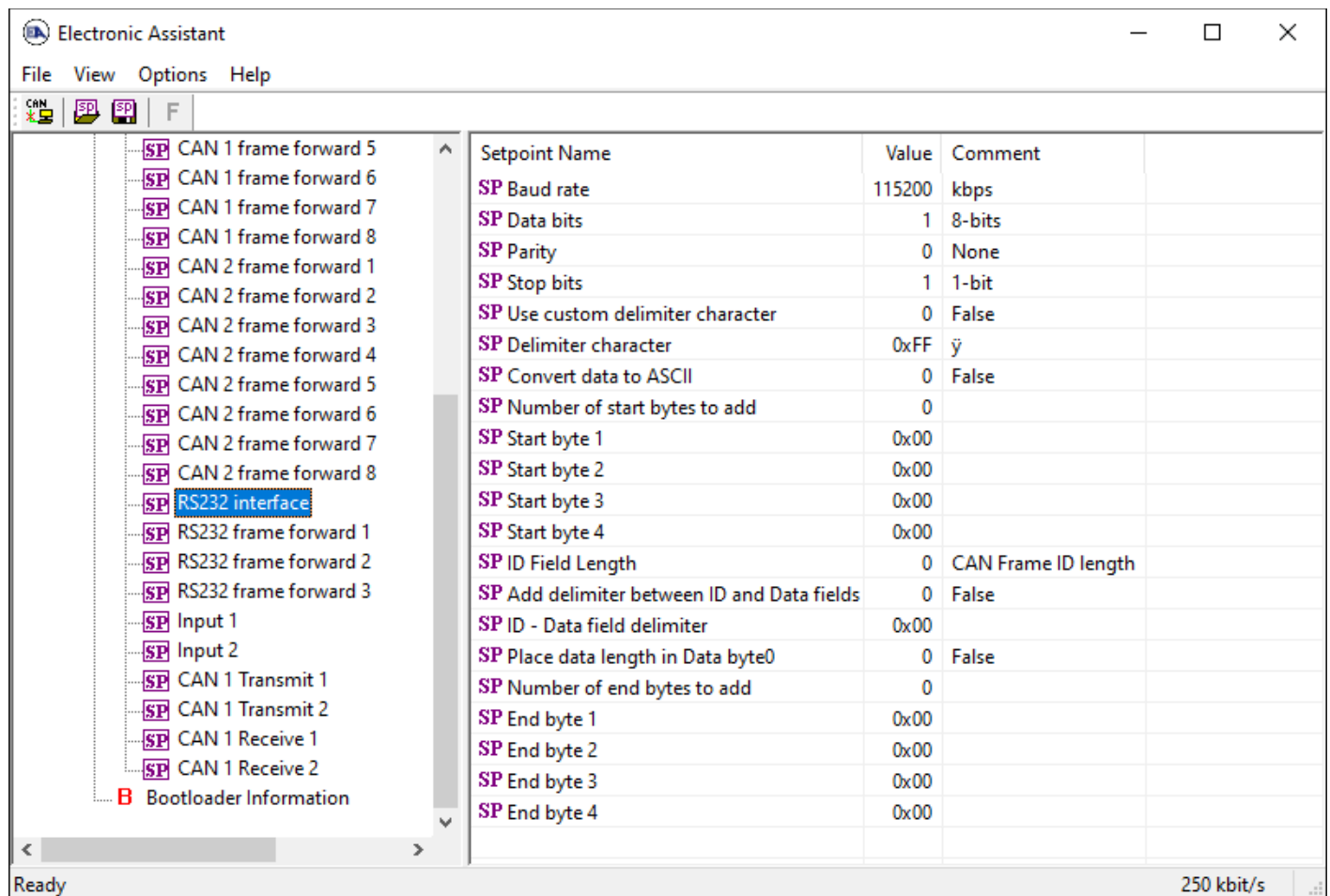

Setpoint Name	Value	Comment
SP Baud rate	115200	kbps
SP Data bits	1	8-bits
SP Parity	0	None
SP Stop bits	1	1-bit
SP Use custom delimiter character	0	False
SP Delimiter character	0xFF	ÿ
SP Convert data to ASCII	0	False
SP Number of start bytes to add	0	
SP Start byte 1	0x00	
SP Start byte 2	0x00	
SP Start byte 3	0x00	
SP Start byte 4	0x00	
SP ID Field Length	0	CAN Frame ID length
SP Add delimiter between ID and Data fields	0	False
SP ID - Data field delimiter	0x00	
SP Place data length in Data byte0	0	False
SP Number of end bytes to add	0	
SP End byte 1	0x00	
SP End byte 2	0x00	
SP End byte 3	0x00	
SP End byte 4	0x00	

Figure 8 – Screen Capture of RS-232 interface Setpoints

<b>Name</b>	<b>Range</b>	<b>Default</b>	<b>Notes</b>
Baud rate	300 to 921600	1152000	
Data bits	Drop List	1 – 8-bits	See Table 8
Parity	Drop List	0 – None	See Table 9
Stop bits	Drop List	1 – 1 bit	See Table 10
Use custom delimiter character	False/True	0 – False	
Delimiter character	0x00 to 0xFF	0xFF	
Convert data to ASCII	False/True	0 – False	See Section 1.2.1
Number of start bytes to add	0 to 4	0	
Start byte 1	0x00 to 0xFF	0x00	
Start byte 2	0x00 to 0xFF	0x00	
Start byte 3	0x00 to 0xFF	0x00	
Start byte 4	0x00 to 0xFF	0x00	
ID Field Length	Drop List	0 – CAN Frame ID Length	See Table 11
Add delimiter between ID and Data fields	False/True	0 – False	
ID - Data field delimiter	0x00 to 0xFF	0x00	
Place data length in Data byte0	False/True	0 – False	
Number of end bytes to add	0 to 4	0	
End byte 1	0x00 to 0xFF	0x00	
End byte 2	0x00 to 0xFF	0x00	
End byte 3	0x00 to 0xFF	0x00	
End byte 4	0x00 to 0xFF	0x00	

**Table 30 – RS-232 interface Setpoints**

## 4.6. RS-232 Frame forward Setpoints

The RS-232 Frame Forward is described in Section 1.2.3. Please refer there for detailed information about how these setpoints are used.

Setpoint Name	Value	Comment
SP Forward rule Enable Source	0	Enable Not Used
SP Forward rule Enable Number	0	(Always enabled)
SP Match filter	0x0000000000000000	
SP Mask filter	0x0000000000000000	
SP Number of start bytes to add	0	
SP Start byte 1	0x00	
SP Start byte 2	0x00	
SP Start byte 3	0x00	
SP Start byte 4	0x00	
SP Number of end bytes to add	0	
SP End byte 1	0x00	
SP End byte 2	0x00	
SP End byte 3	0x00	
SP End byte 4	0x00	
SP CAN ID Type	0	ExtID
SP Add CAN frame ID	0	False
SP CAN ID	0x00000000	
SP Use multipacket transport protocol (CAN1)	0	False
SP Add frame index to byte 0	0	False
SP Forward all data bytes	0	Forward all data bytes
SP Number of data bytes to forward	8	
SP Output 1	0	Not used
SP Output 2	0	Not used
SP Output 3	0	Not used

Figure 9 – Screen RS-232 Frame forward Setpoints

Name	Range	Default	Notes
Forward rule Enable Source	Drop List	0 – Enable Not Used	See Table 23
Forward rule Enable Number	1 to 2	0 (Always enabled)	See Table 23
Match filter	0x0000000000 to 0xFFFFFFFF	0x00	See section 1.2.3
Match mask	0x0000000000 to 0xFFFFFFFF	0x00	See section 1.2.3
Number of start bytes to add	0 to 4	0	
Start byte 1	0x00 to 0xFF	0x00	
Start byte 2	0x00 to 0xFF	0x00	
Start byte 3	0x00 to 0xFF	0x00	
Start byte 4	0x00 to 0xFF	0x00	
Number of end bytes to add	0 to 4	0	
End byte 1	0x00 to 0xFF	0x00	
End byte 2	0x00 to 0xFF	0x00	
End byte 3	0x00 to 0xFF	0x00	
End byte 4	0x00 to 0xFF	0x00	
Add CAN frame ID	False/True	0 – False	
CAN ID type	Drop List	0 – ExtID	See Table 14
CAN ID	0x00000000 to 0x1FFFFFFF	0x00	
Use multipacket transport protocol	0 to 10	1.00	
Forward all data bytes	Drop List	0 – Forward all data bytes	See Table 12
Number of data bytes to forward	0 to 128	8	
Add frame index to byte 0	False/True	0 – False	
Output 1	Drop List	0 – Not used	See Table 13
Output 2	Drop List	0 – Not used	See Table 13
Output 3	Drop List	0 – Not used	See Table 13

**Table 31 – RS-232 Frame forward Setpoints**

## 4.7. Input Setpoints

The Digital Signal Inputs are defined in Section 1.3. The setpoint group input software filter setpoints. The Input software filters are presented in section 1.4.

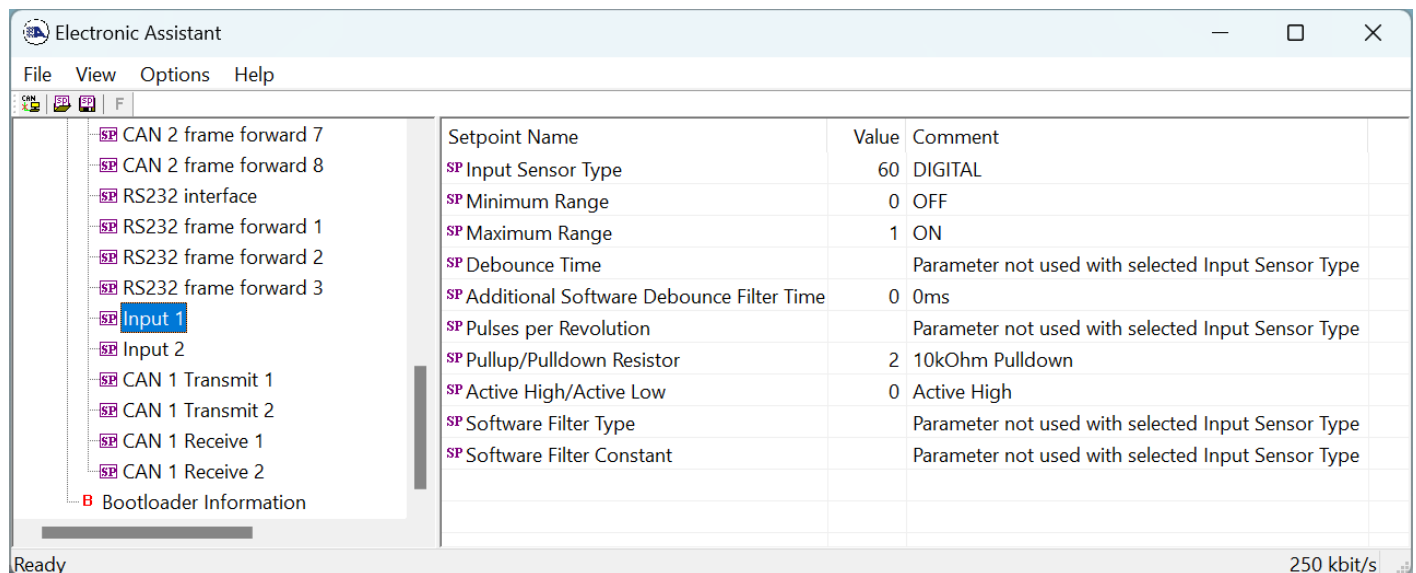

**Figure 10 – Screen Capture of Input Setpoints**

Name	Range	Default	Notes
Input Sensor Type	Drop List	60 – DIGITAL	See Table 15
Minimum Range	From Input type minimum to Maximum Range	Depends on Input Sensor Type	
Maximum Range	From Minimum Range to Input type maximum	Depends on Input Sensor Type	
Debounce Time	Drop List	0 – None	See Table 16
Additional Software Debounce Filter Time	Drop List	0ms	See Table 17
Pulses per Revolution	Drop List	0 – False	See Section
Measuring Window	1..65535	1000 Pulse(s)	
Maximum Pulse Count	1..65535	10 Pulse(s)	
Pullup/Pulldown Resistor	Drop List	10kΩ Pulldown	See Table 18
Active High/Active Low	Drop List	0 – Active High	See Table 19
Software Filter Type	Drop List	0 – No Filtering	See Table 21
Software Filter Constant	1..1000	1000	

**Table 32 – Input Setpoints**

## 4.8. CAN Transmit Setpoints

CAN Transmit Message Function Block is presented in Section 1.5. Please refer there for detailed information on how these setpoints are used. “**Transmit Repetition Rate**” is 0ms by default, thus no message will be sent.

The screenshot shows the Electronic Assistant software interface. On the left, a tree view displays the configuration for a J1939 CAN Network, with 'CAN 1 Transmit 1' selected. The main area shows a table of setpoints for this configuration.

Setpoint Name	Value	Comment
SP Transmit PGN	0xFF80	Transmit PGN: 65408
SP Transmit Repetition Rate	0	ms
SP Transmit Message Priority	6	
SP Destination Address (PDU1)		Parameter not used with this PGN
SP Signal 1 Data Source	2	Input Measured
SP Signal 1 Data Number	1	Input Measured #1
SP Signal 1 Transmit Data Type	2	CAN signal continuous
SP Signal 1 Transmit Data Width	8	
SP Signal 1 Transmit Data Index in Array (LSB)	0	1st Byte Position
SP Signal 1 Transmit Bit Index in Byte (LSB)	0	1st Bit Position
SP Signal 1 Transmit Data Resolution	1.0000000	
SP Signal 1 Transmit Data Offset	0.0000000	
SP Signal 2 Data Source	0	Control Not Used
SP Signal 2 Data Number		Parameter not used with current Data Source
SP Signal 2 Transmit Data Type		Parameter not used with current Data Source
SP Signal 2 Transmit Data Width		Parameter not used with current Data Source
SP Signal 2 Transmit Data Index in Array (LSB)		Parameter not used with current Data Source
SP Signal 2 Transmit Bit Index in Byte (LSB)		Parameter not used with current Data Source
SP Signal 2 Transmit Data Resolution		Parameter not used with current Data Source
SP Signal 2 Transmit Data Offset		Parameter not used with current Data Source
SP Signal 3 Data Source	0	Control Not Used
SP Signal 3 Data Number		Parameter not used with current Data Source
SP Signal 3 Transmit Data Type		Parameter not used with current Data Source
SP Signal 3 Transmit Data Width		Parameter not used with current Data Source
SP Signal 3 Transmit Data Index in Array (LSB)		Parameter not used with current Data Source
SP Signal 3 Transmit Bit Index in Byte (LSB)		Parameter not used with current Data Source
SP Signal 3 Transmit Data Resolution		Parameter not used with current Data Source
SP Signal 3 Transmit Data Offset		Parameter not used with current Data Source
SP Signal 4 Data Source	0	Control Not Used
SP Signal 4 Data Number		Parameter not used with current Data Source
SP Signal 4 Transmit Data Type		Parameter not used with current Data Source
SP Signal 4 Transmit Data Width		Parameter not used with current Data Source
SP Signal 4 Transmit Data Index in Array (LSB)		Parameter not used with current Data Source
SP Signal 4 Transmit Bit Index in Byte (LSB)		Parameter not used with current Data Source
SP Signal 4 Transmit Data Resolution		Parameter not used with current Data Source
SP Signal 4 Transmit Data Offset		Parameter not used with current Data Source

The status bar at the bottom indicates 'Ready' and a data rate of '250 kbit/s'.

Figure 11 – Screen Capture of CAN Transmit Message Setpoints

Name	Range	Default	Notes
Transmit PGN	0xff00 ... 0xffff	Different for each	See Section 1.5.1
Transmit Repetition Rate	0 ... 65000 ms	0ms	0ms disables transmit
Transmit Message Priority	0...7	6	Proprietary B Priority
Destination Address	0...255	255	Not used by default
Signal 1 Control Source	Drop List	Signal undefined	See Table 23
Signal 1 Control Number	Drop List	Signal undefined	See 1.5.2
Signal 1 Transmit Data Type	Drop List	CAN signal continuous	
Signal 1 Transmit Data Width	1-32	8	
Signal 1 Transmit Data Index in Array	0-7	0	
Signal 1 Transmit Bit Index In Byte	0-7	0	
Signal 1 Transmit Data Resolution	-100000.0 to 100000	1	
Signal 1 Transmit Data Offset	-10000 to 10000	0.0	
Signal 2 Control Source	Drop List	Signal undefined	See Table 23
Signal 2 Control Number	Drop List	Signal undefined	See 1.5.2
Signal 2 Transmit Data Type	Drop List	CAN signal continuous	
Signal 2 Transmit Data Width	1-32	8	
Signal 2 Transmit Data Index in Array	0-7	1	
Signal 2 Transmit Bit Index In Byte	0-7	0	
Signal 2 Transmit Data Resolution	-100000.0 to 100000	1	
Signal 2 Transmit Data Offset	-10000 to 10000	0.0	
Signal 3 Control Source	Drop List	Signal undefined	See Table 23
Signal 3 Control Number	Drop List	Signal undefined	See 1.5.2
Signal 3 Transmit Data Type	Drop List	CAN signal continuous	
Signal 3 Transmit Data Width	1-32	8	
Signal 3 Transmit Data Index in Array	0-7	2	
Signal 3 Transmit Bit Index In Byte	0-7	0	
Signal 3 Transmit Data Resolution	-100000.0 to 100000	1	
Signal 3 Transmit Data Offset	-10000 to 10000	0.0	
Signal 4 Control Source	Drop List	Signal undefined	See Table 23
Signal 4 Control Number	Drop List	Signal undefined	See 1.5.2
Signal 4 Transmit Data Type	Drop List	CAN signal continuous	
Signal 4 Transmit Data Width	1-32	8	
Signal 4 Transmit Data Index in Array	0-7	3	
Signal 4 Transmit Bit Index In Byte	0-7	0	
Signal 4 Transmit Data Resolution	-100000.0 to 100000	1	
Signal 4 Transmit Data Offset	-10000 to 10000	0.0	

**Table 33 – CAN Transmit Message Setpoints**



## 4.9. CAN Receive Setpoints

The Digital Signal Inputs are defined in Section 1.3. The setpoint group input software filter setpoints. The Input software filters are presented in section 1.4.

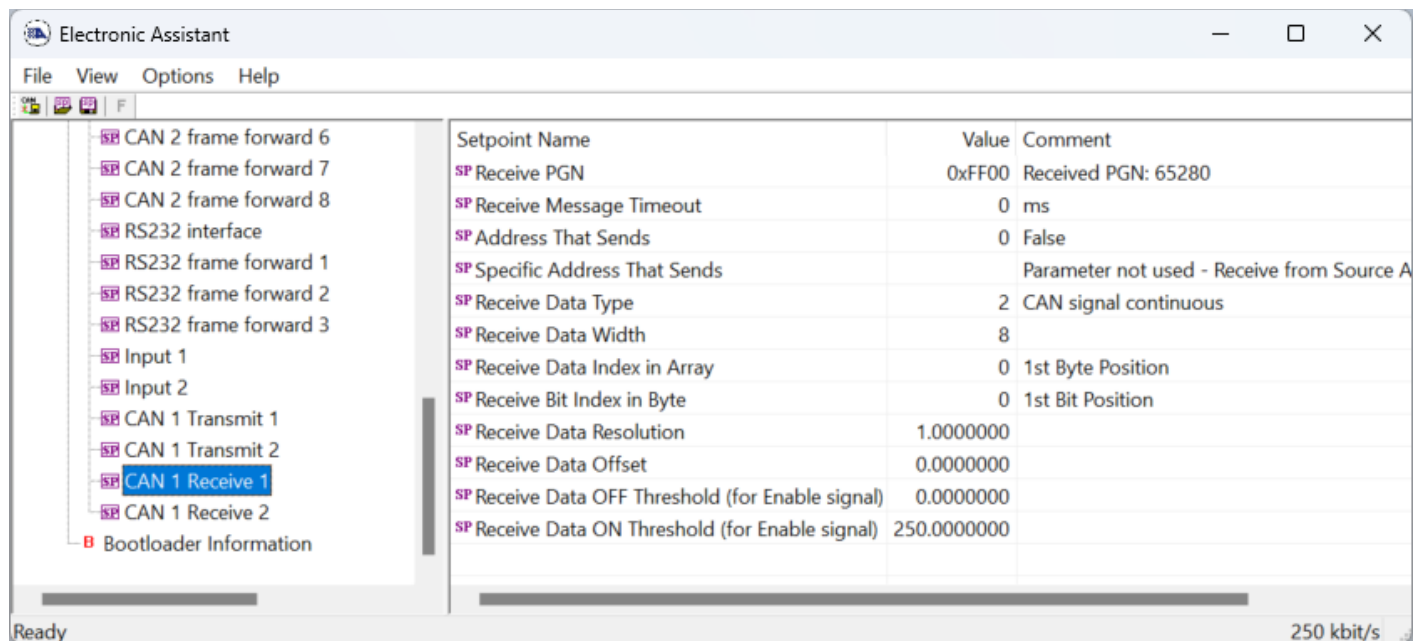

**Figure 12 – Screen Capture of Input Setpoints**

Name	Range	Default	Notes
Received Message Enabled	Drop List	False	
Received PGN	0 to 65536	Different for each	See 4.9
Received Message Timeout	0 to 60 000 ms	0ms	
Address That Sends	Drop List	False	See 4.9
Specific Address That Sends	0 to 255	0x00	
Receive Data Type	Drop List	CAN signal continuous	See Table 22
Receive Data Width	0-8	8	
Receive Data Index in Array	0-7	0	
Receive Bit Index in Byte	0-7	0	
Receive Data Resolution	-100000.0 to 100000	1	
Receive Data Offset	-10000 to 10000	0.0	
Receive Data OFF Threshold	0 to ON Threshold	0.0	
Receive Data ON Threshold	OFF Threshold to 0xFFFFFFFF	250	

**Table 34 – Input Setpoints**

## 5. REFLASHING OVER CAN WITH EA BOOTLOADER

The AX030355 can be upgraded with new application firmware using the **Bootloader Information** section. This section details the simple step-by-step instructions to upload new firmware provided by Axiomatic onto the unit via CAN, without requiring it to be disconnected from the J1939 network.

*Note: To upgrade the firmware, use the Axiomatic Electronic Assistant **VX.XX.XX.0** or higher.*

1. When EA first connects to the ECU, the **Bootloader Information** section will display the following information.

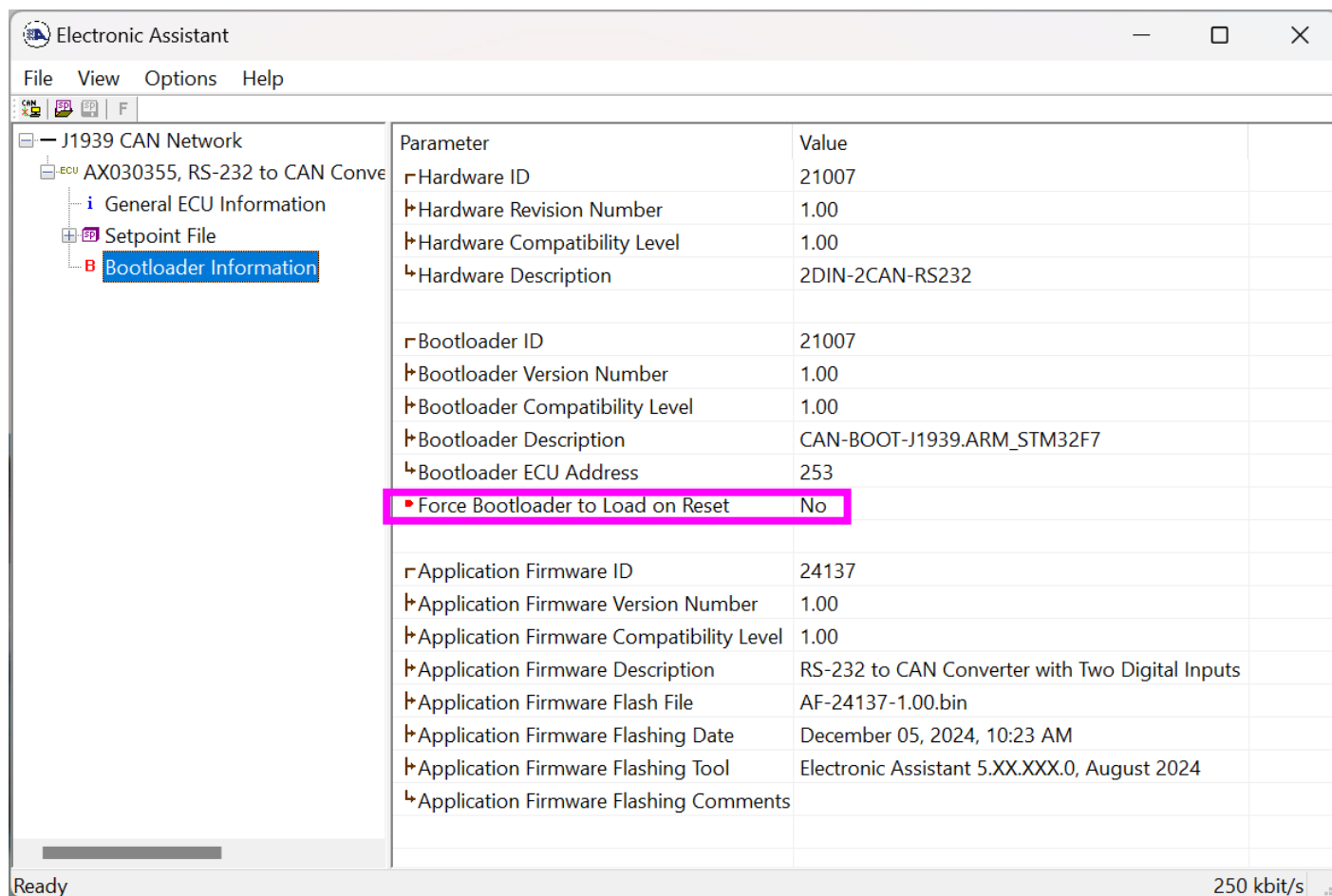

The screenshot shows the Electronic Assistant software window. The left sidebar displays a tree view with 'J1939 CAN Network' expanded to show 'ECU AX030355, RS-232 to CAN Converter', which includes 'General ECU Information', 'Setpoint File', and 'Bootloader Information' (highlighted in blue). The main area shows a table of parameters and their values. The 'Force Bootloader to Load on Reset' parameter is highlighted with a pink border.

Parameter	Value
Hardware ID	21007
Hardware Revision Number	1.00
Hardware Compatibility Level	1.00
Hardware Description	2DIN-2CAN-RS232
Bootloader ID	21007
Bootloader Version Number	1.00
Bootloader Compatibility Level	1.00
Bootloader Description	CAN-BOOT-J1939.ARM_STM32F7
Bootloader ECU Address	253
Force Bootloader to Load on Reset	No
Application Firmware ID	24137
Application Firmware Version Number	1.00
Application Firmware Compatibility Level	1.00
Application Firmware Description	RS-232 to CAN Converter with Two Digital Inputs
Application Firmware Flash File	AF-24137-1.00.bin
Application Firmware Flashing Date	December 05, 2024, 10:23 AM
Application Firmware Flashing Tool	Electronic Assistant 5.XX.XXX.0, August 2024
Application Firmware Flashing Comments	

Ready 250 kbit/s

2. To use the bootloader to upgrade the firmware running on the ECU, change the variable “**Force Bootloader To Load on Reset**” to Yes.

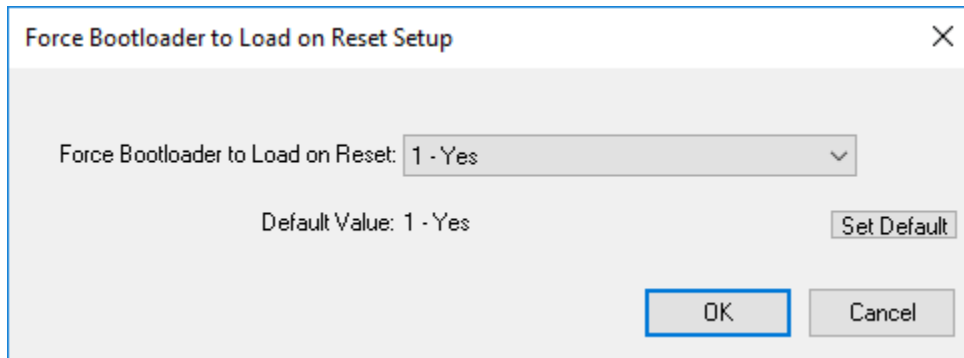

3. When the prompt box asks if you want to reset the ECU, select Yes.

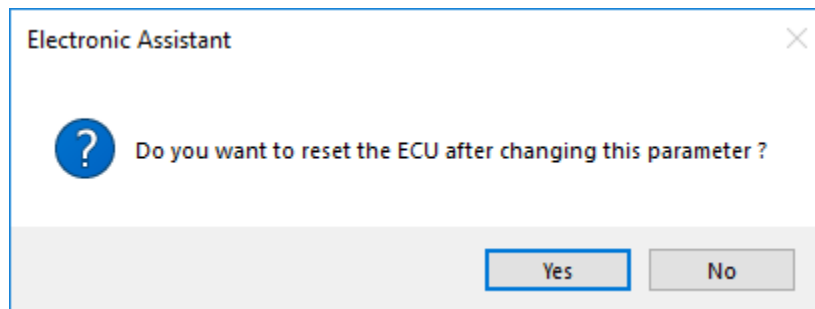

4. Upon reset, the ECU will no longer show up on the J1939 network as an AX030355 but rather as **J1939 Bootloader #1**.

The screenshot shows the 'Electronic Assistant' window with a table of ECU information. The table has columns for ECU, J1939 NAME, Address, and J1939 Preferred ... The status bar at the bottom indicates 'Ready' and a speed of '250 kbit/s'.

ECU	J1939 NAME	Address	J1939 Preferred ...
ECU J1939 Bootloader #1	0X00FEFF0014428733	0XFD	Reserved for OEM

The screenshot shows the 'Electronic Assistant' window with detailed ECU information for 'J1939 Bootloader #1'. The left sidebar shows a tree view with 'General ECU Information' selected. The main area displays a table of parameters and their values.

Parameter	Value	Description
ECU Part Number	AX030350	
ECU Serial Number	0024420001	
ECU J1939 NAME		PGN 60928. 64-bit ECU Identifier sent in Address Claimed Messages
Arbitrary Address Capable	0X00	No
Industry Group	0X00	Global
Vehicle System Instance	0X00	
Vehicle System	0X7F	Not Available
Reserved	0X00	
Function	0XFF	Not Available
Function Instance	0X00	
ECU Instance	0X00	#1 - First Instance
Manufacturer Code	0X0A2	Axiomatic Technologies
Identity Number	0X1B894E	Unique ECU network ID number
ECU Address	0XFD	Reserved for OEM
ECU ID	N/A	PGN 64965 -ECUID
Software ID	N/A	PGN 65242 -SOFT

*Note that the bootloader is NOT Arbitrary Address Capable. This means that if you want to have multiple bootloaders running simultaneously (not recommended) you would have to manually change the address for each one before activating the next, or there will be address conflicts. And only one ECU would show up as the bootloader. Once the 'active' bootloader returns to regular functionality, the other ECU(s) would have to be power cycled to re-activate the bootloader feature.*

5. When the **Bootloader Information** section is selected, the same information is shown as when it was running the AX030355 firmware, but in this case the **Flashing** feature has been enabled.

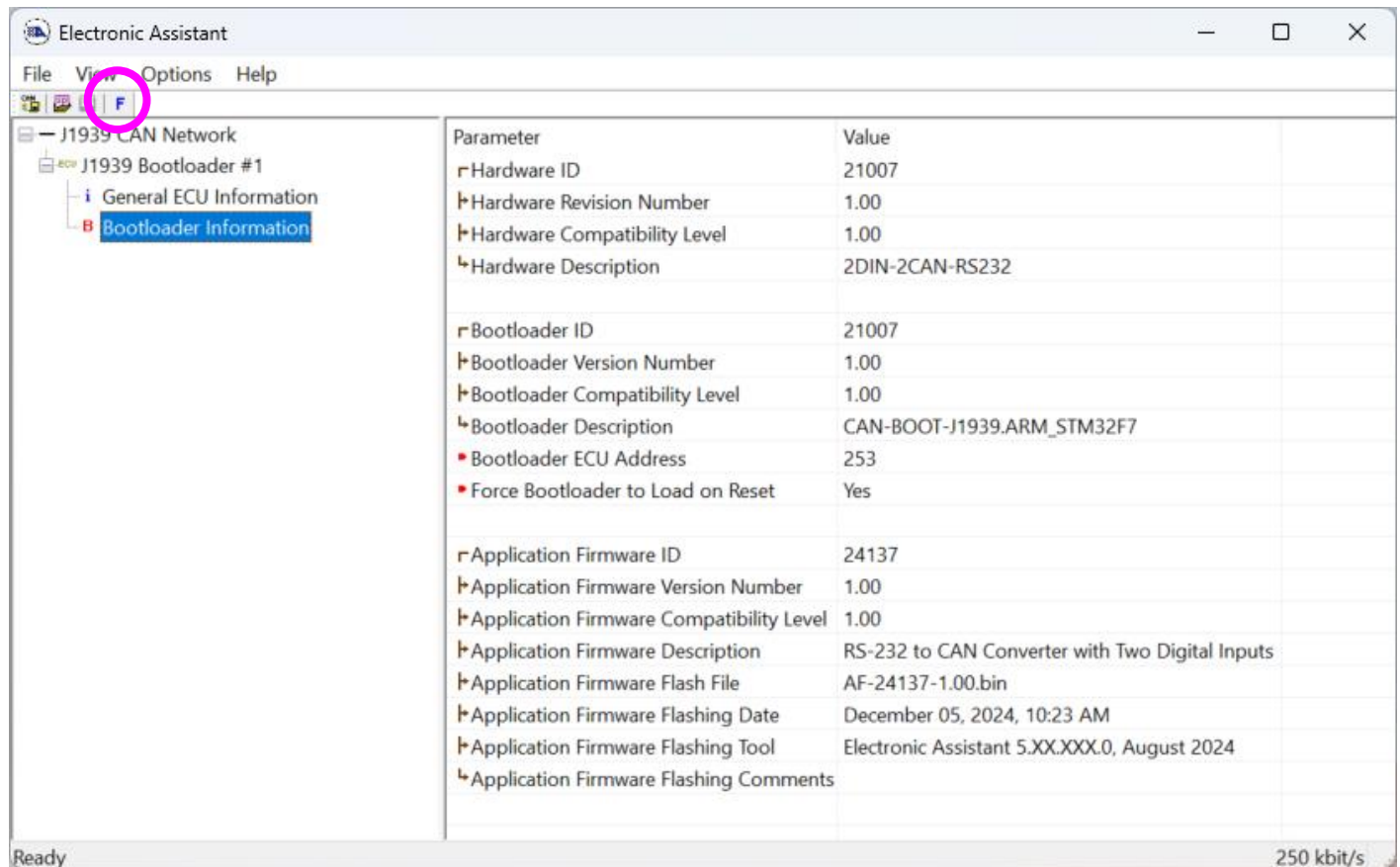

6. Select the **Flashing** button and navigate to where you had saved the **AX030355\_Simulink.bin** file sent from Axiomatic. (Note: only binary (.bin) files can be flashed using the EA tool.)

7. Once the Flash Application Firmware window opens, you can enter comments such as “Firmware upgraded by [Name]” if you so desire. This is not required, and you can leave the field blank if you do not want to use it.

Note: You do not have to date/timestamp the file, as this is done automatically by the EA tool when you upload the new firmware.

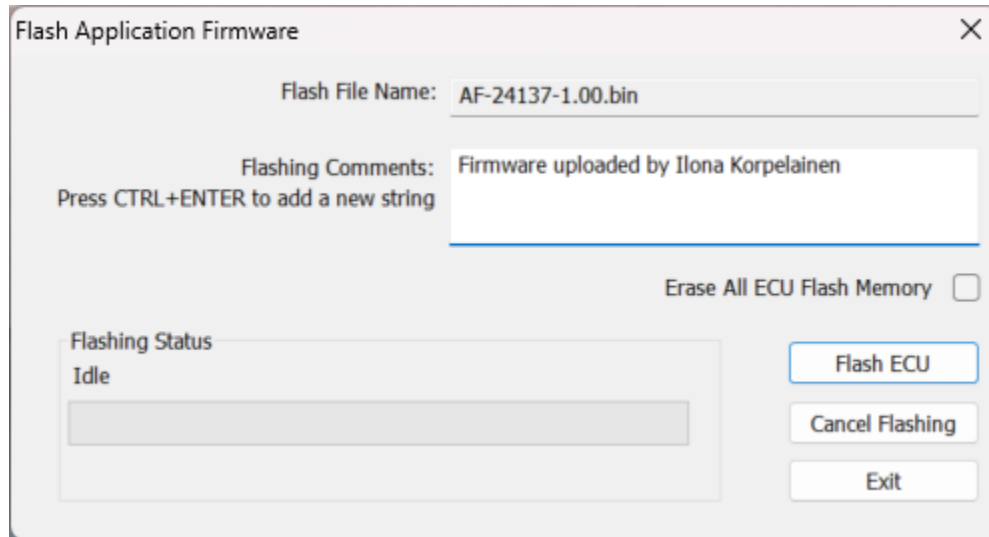

**WARNING:** Do not check the “Erase All ECU Flash Memory” box unless instructed to do so by your Axiomatic contact. Selecting this will erase ALL data stored in non-volatile flash including the calibration from Axiomatic factory testing. It will also erase any configuration of the setpoints that might have been done to the ECU and reset all setpoints to their factory defaults. By leaving this box unchecked, none of the setpoints will be changed when the new firmware is uploaded.

A progress bar will show how much of the firmware has been sent as the upload progresses. The more traffic there is on the J1939 network, the longer the upload process will take.

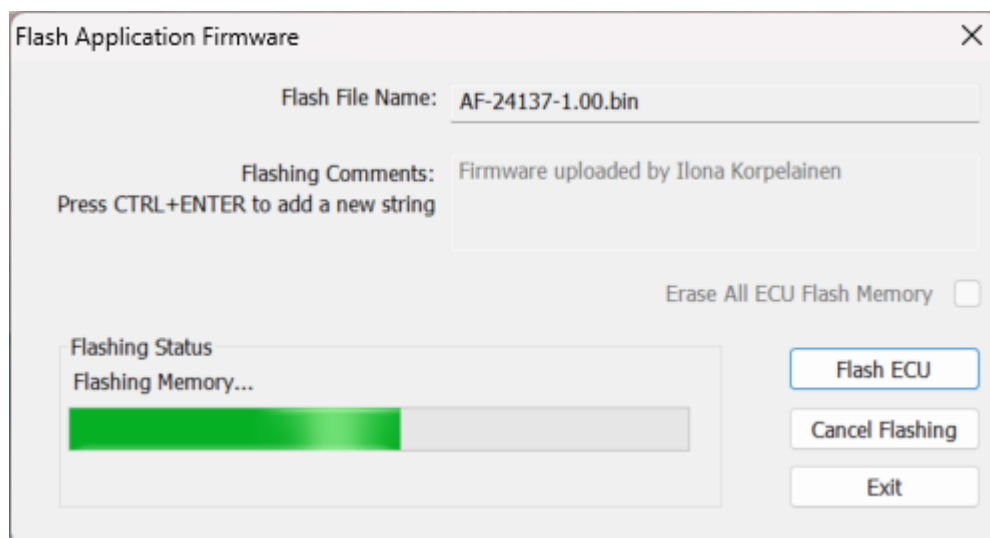

Once the firmware has finished uploading, a message will pop up indicating the successful operation. If you select to reset the ECU, the new version of the AX030355 application will start running, and the ECU will be identified as such by EA. Otherwise, the next time the ECU is power-cycled, the AX030355 application will run rather than the bootloader function.

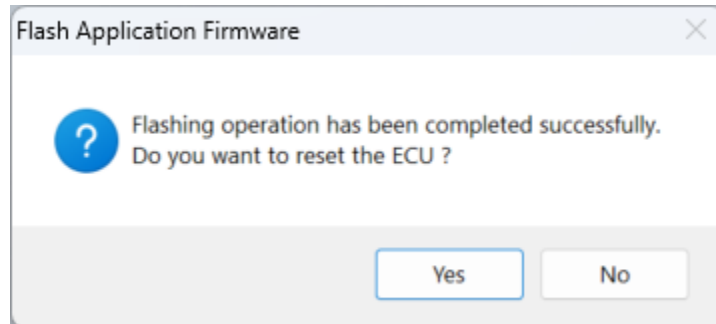

Note: If at any time during the upload the process is interrupted, the data is corrupted (bad checksum) or for any other reason the new firmware is not correct, i.e. bootloader detects that the file loaded was not designed to run on the hardware platform, the bad or corrupted application will not run. Rather, when the ECU is reset or power-cycled the **J1939 Bootloader** will continue to be the default application until valid firmware has been successfully uploaded into the unit.

## APPENDIX A - TECHNICAL SPECIFICATION

Specifications are indicative and subject to change. Actual performance will vary depending on the application and operating conditions. Users should satisfy themselves that the product is suitable for use in the intended application. All our products carry a limited warranty against defects in material and workmanship. Please refer to our Warranty, Application Limitations & Return Materials Process as described on <https://www.axiomatic.com/service/>.

### Power Supply

Power Supply Input	12 Vdc or 24 Vdc nominal operating voltage 9 Vdc to 36 Vdc power supply range
Quiescent Current	80 mA @ 12 Vdc; 50 mA @ 24 Vdc typical
Maximum Current Draw	150 mA at 12 Vdc
Reverse Polarity Protection	Protection up to -50 V
Undervoltage Protection	Shutdown at 6 Vdc
Overvoltage Protection	Protection up to 38 V

### Input

Inputs	2 inputs user programmable as timer inputs (frequency/RPM, PWM) or digital signal inputs
Frequency/RPM Input	0.5 Hz to 50 Hz; 10 Hz to 1 kHz; or 100 Hz to 10 kHz 0.01% resolution ±0.1% error
PWM Input	Low frequency (0.50 Hz to 1 kHz) High frequency (100 Hz to 10 kHz) 0 to 100% DC 0.01% resolution ±0.1% error PWM Voltage (pk-pk): 0-36V
Digital Input	1 MΩ Impedance Active high or active low with 10 kΩ pull-up or pull-down
Digital Input Levels	Accepts 5 V TTL Accepts up to Vps Threshold: Low <1 V, High >2.2 V
Input Ground	1 provided
Protection	All inputs are protected against short to Ground. All inputs are protected against shorts to nominal Vps.



## General Specifications

Microcontroller	STM32F767VG
Isolation	300 Vrms Isolation between CAN and power/inputs
Communications	2 isolated CAN ports (SAE J1939) Can convert CAN ID and CAN data into ASCII format to produce readable text, for example, to a serial terminal application on a PC  1 RS-232 port with programmable "frame format" (1 delimiter byte and up to 4 start and end bytes can be added to the forwarded frames which makes it possible to parse the information at the RS-232 receiver.)
CAN Baud Rate	250 kbit/s, 500 kbit/s, 667 kbit/s, 1 Mbit/s auto-baud-rate detection
Network Termination	It is necessary to terminate the network with external termination resistors. The resistors are 120 $\Omega$ , 0.25 W minimum, metal film or similar type. They should be placed between CAN_H and CAN_L terminals at both ends of the network.
Operating Conditions	-40°C to 85°C (-40°F to 185°F)
Storage Temperature	-55°C to 125°C (-67°F to 257°F)
Protection	IP67
Compliance	RoHS
Weight	0.15 lb. (0.070 kg)
Enclosure	Molded enclosure, ultrasonically welded Integral connector Nylon 6/6, 30% glass 3.55 in x 2.76 in x 1.31 in (90.1 mm x 70 mm x 33.4 mm) L x W x H including integral connector Refer to the Dimensional Drawing.
Electrical Connections	Integral 12-pin receptacle (equivalent to TE Deutsch P/N: DTM04-12PA)
Mating Plug Kit	Axiomatic P/N: <b>PL-DTM06-12SA</b> (includes TE Deutsch P/Ns: 1x DTM06-12SA, 1x WM-12S, 12x 0462-201-20141, 6x 0413-204-2005 Sealing Plugs)
Mounting	Mounting holes are sized for #8 or M4 bolts. The bolt length will be determined by the end-user's mounting plate thickness. The mounting flange of the controller is 0.43 inches (10.8 mm) thick. If the module is mounted without an enclosure, it should be mounted vertically with connectors facing left or right to reduce the likelihood of moisture entry. CAN wiring is considered intrinsically safe. The power wires are not considered intrinsically safe and so in hazardous locations, they need to be located in conduit or conduit trays at all times. The module must be mounted in an enclosure in hazardous locations for this purpose. No wire or cable harness should exceed 30 meters in length. The power input wiring should be limited to 10 meters. All field wiring should be suitable for the operating temperature range. Install the unit with appropriate space available for servicing and for adequate wire harness access (6 inches or 15 cm) and strain relief (12 inches or 30 cm).

## OUR PRODUCTS

AC/DC Power Supplies  
Actuator Controls/Interfaces  
Automotive Ethernet Interfaces  
Battery Chargers  
CAN Controls, Routers, Repeaters  
CAN/WiFi, CAN/Bluetooth, Routers  
Current/Voltage/PWM Converters  
DC/DC Power Converters  
Engine Temperature Scanners  
Ethernet/CAN Converters,  
Gateways, Switches  
Fan Drive Controllers  
Gateways, CAN/Modbus, RS-232  
Gyroscopes, Inclinometers  
Hydraulic Valve Controllers  
Inclinometers, Triaxial  
I/O Controls  
LVDT Signal Converters  
Machine Controls  
Modbus, RS-422, RS-485 Controls  
Motor Controls, Inverters  
Power Supplies, DC/DC, AC/DC  
PWM Signal Converters/Isolators  
Resolver Signal Conditioners  
Service Tools  
Signal Conditioners, Converters  
Strain Gauge CAN Controls  
Surge Suppressors

## OUR COMPANY

Axiomatic provides electronic machine control components to the off-highway, commercial vehicle, electric vehicle, power generator set, material handling, renewable energy and industrial OEM markets. ***We innovate with engineered and off-the-shelf machine controls that add value for our customers.***

## QUALITY DESIGN AND MANUFACTURING

We have an ISO9001:2015 registered design/manufacturing facility in Canada.

## WARRANTY, APPLICATION APPROVALS/LIMITATIONS

Axiomatic Technologies Corporation reserves the right to make corrections, modifications, enhancements, improvements, and other changes to its products and services at any time and to discontinue any product or service without notice. Customers should obtain the latest relevant information before placing orders and should verify that such information is current and complete. Users should satisfy themselves that the product is suitable for use in the intended application. All our products carry a limited warranty against defects in material and workmanship. Please refer to our Warranty, Application Approvals/Limitations and Return Materials Process at <https://www.axiomatic.com/service/>.

## COMPLIANCE

Product compliance details can be found in the product literature and/or on [axiomatic.com](http://axiomatic.com). Any inquiries should be sent to [sales@axiomatic.com](mailto:sales@axiomatic.com).

## SAFE USE

All products should be serviced by Axiomatic. Do not open the product and perform the service yourself.



This product can expose you to chemicals which are known in the State of California, USA to cause cancer and reproductive harm. For more information go to [www.P65Warnings.ca.gov](http://www.P65Warnings.ca.gov).

## SERVICE

All products to be returned to Axiomatic require a Return Materials Authorization Number (RMA#) from [rma@axiomatic.com](mailto:rma@axiomatic.com). Please provide the following information when requesting an RMA number:

- Serial number, part number
- Runtime hours, description of problem
- Wiring set up diagram, application and other comments as needed

## DISPOSAL

Axiomatic products are electronic waste. Please follow your local environmental waste and recycling laws, regulations and policies for safe disposal or recycling of electronic waste.

## CONTACTS

**Axiomatic Technologies Corporation**  
1445 Courtneypark Drive E.  
Mississauga, ON  
CANADA L5T 2E3  
TEL: +1 905 602 9270  
FAX: +1 905 602 9279  
[www.axiomatic.com](http://www.axiomatic.com)  
[sales@axiomatic.com](mailto:sales@axiomatic.com)

**Axiomatic Technologies Oy**  
Höytämöntie 6  
33880 Lempäälä  
FINLAND  
TEL: +358 103 375 750  
[www.axiomatic.com](http://www.axiomatic.com)  
[salesfinland@axiomatic.com](mailto:salesfinland@axiomatic.com)