



USER MANUAL UMAX030780

Version 1.0.4

1x Input, 2x Analog & 2x 5A Proportional Outputs Controller SAE J1939

USER MANUAL

P/N: AX030780

VERSION HISTORY

| Version | Date | Author | Modification |
|----------------|--------------------|---------------|---|
| 1.0.0 | July 3, 2025 | Weixin Kong | Initial Draft |
| 1.0.1 | September 11, 2025 | M Ejaz | Marketing review Updated the product title Updated the dimensional drawing, block diagram, and technical specifications |
| 1.0.2 | December 2, 2025 | Weixin Kong | Updated P/N |
| 1.0.3 | December 17, 2025 | M Ejaz | Updated title Updated block diagram Updated dimensional drawing and pinout table |
| 1.0.4 | January 28, 2026 | M Ejaz | Updated technical specifications |

ACRONYMS

| | |
|----------|---|
| ACK | Positive Acknowledgement (from SAE J1939 standard) |
| BATT +/- | Battery positive (a.k.a. Vps) or Battery Negative (a.k.a. GND) |
| DIN | Digital Input used to measure active high or low signals |
| DM | Diagnostic Message (from SAE J1939 standard) |
| DTC | Diagnostic Trouble Code (from SAE J1939 standard) |
| EA | Axiomatic Electronic Assistant (A Service Tool for Axiomatic ECUs) |
| ECU | Electronic Control Unit (from SAE J1939 standard) |
| GND | Ground reference (a.k.a. BATT-) |
| I/O | Inputs and Outputs |
| MAP | Memory Access Protocol |
| NAK | Negative Acknowledgement (from SAE J1939 standard) |
| PDU1 | A format for messages that are to be sent to a destination address, either specific or global (from SAE J1939 standard) |
| PDU2 | A format used to send information that has been labeled using the Group Extension technique and does not contain a destination address. |
| PGN | Parameter Group Number (from SAE J1939 standard) |
| PropA | Message that uses the Proprietary A PGN for peer-to-peer communication |
| PropB | Message that uses a Proprietary B PGN for broadcast communication |
| PWM | Pulse Width Modulation |
| RPM | Rotations per Minute |
| SPN | Suspect Parameter Number (from SAE J1939 standard) |
| TP | Transport Protocol |
| UIN | Universal input used to measure voltage, current, frequency or digital inputs |
| Vps | Voltage Power Supply (a.k.a. BATT+) |
| %dc | Percent Duty Cycle (Measured from a PWM input) |

TABLE OF CONTENTS

| | |
|--|-----------|
| 1. OVERVIEW OF CONTROLLER | 9 |
| 1.1. Digital Input Function Blocks | 11 |
| 1.1.1. Input Polarity | 11 |
| 1.1.2. Discrete Input Debounce Time | 11 |
| 1.2. Proportional Output Function Blocks | 12 |
| 1.3. H-Bridge Function Block | 16 |
| 1.4. Analog Output | 18 |
| 1.4.1. Analog Current/Voltage | 18 |
| 1.4.2. Digital ON/OFF | 19 |
| 1.4.3. Common Parameters | 19 |
| 1.5. PID Control Function Block | 21 |
| 1.6. Diagnostic Function Blocks | 23 |
| 1.7. Math Function Block | 27 |
| 1.8. Conditional Block | 28 |
| 1.9. Set / Reset Latch Function Block | 30 |
| 1.10. Lookup Table Function Block | 31 |
| 1.11. Programmable Logic Function Block | 32 |
| 1.12. Constant Data | 33 |
| 1.13. DTC React | 34 |
| 1.14. CAN Transmit Message Function Block | 35 |
| 1.14.1. CAN Transmit Message Setpoints | 35 |
| 1.14.2. CAN Transmit Signal Setpoints | 35 |
| 1.15. CAN Receive Function Block | 37 |
| 1.16. Available Control Sources | 38 |
| 2. INSTALLATION INSTRUCTIONS | 40 |
| 3. OVERVIEW OF J1939 FEATURES | 41 |
| 3.1. Introduction to Supported Messages | 41 |
| 3.2. NAME, Address and Software ID | 42 |
| 4. ECU SETPOINTS ACCESSED WITH AXIOMATIC ELECTRONIC ASSISTANT | 45 |
| 4.1. Accessing the ECU Using Axiomatic Electronic Assistant | 45 |
| 4.2. J1939 Network Parameters | 46 |
| 4.3. Digital Input | 47 |
| 4.4. Proportional Output Setpoints | 48 |
| 4.5. H-Bridge | 50 |
| 4.7. Constant Data List | 52 |
| 4.8. Lookup Table | 53 |
| 4.10. Programmable Logic | 56 |
| 4.11. Math Function Block | 58 |
| 4.12. Conditional Logic Block Setpoints | 60 |
| 4.13. Set-Reset Latch Block | 61 |

| | | |
|-----------|---|-----------|
| 4.14. | CAN Transmit Setpoints | 62 |
| 4.15. | CAN Receive Setpoints | 64 |
| 4.16. | General Diagnostics Options | 65 |
| 4.17. | Diagnostics Blocks..... | 66 |
| 4.18. | DTC React Function Block | 69 |
| 5. | REFLASHING OVER CAN WITH EA BOOTLOADER | 70 |

Table 1 – Input Polarity..... 11

Table 2 – Proportional Output Enable Response Options 12

Table 3 – Override Response Options 12

Table 4 – Output Type Options for Proportional Output..... 13

Table 5 – Digital Response Options 14

Table 6 – Fault Response Options 15

Table 7 – Control Response Options 16

Table 8 – Analog Output Type Options 18

Table 9 – Analog Output Enable Response Options..... 20

Table 10 – Override Response Options 20

Table 11 – PID Response Options 21

Table 12 – Lamp Set by Event in DM1 Options 25

Table 13 – FMI for Event Options..... 25

Table 14 – Low Fault FMIs and corresponding High Fault FMIs 26

Table 15 – Math function X Operator Options 27

Table 16 – Input Operator Options 28

Table 17 – Condition Operator Options 29

Table 18 – Set-Reset Function block operation. 30

Table 19 – X-Axis Type Options 31

Table 20 – PointN – Response Options 31

Table 21 – Table X – Condition Y Operator Options 32

Table 22 – Table X – Conditions Logical Operator Options 32

Table 23 – Available Control Sources and Numbers 38

Table 24 – AX030780 Connector Pinout..... 40

Table 25 – J1939 Network Setpoints..... 46

Table 26 – Proportional Output Setpoints 47

Table 27 – Proportional Output Setpoints 49

Table 28 – H-Bridge Output Setpoints 50

Table 29 – Lookup Table Setpoints..... 54

Table 30 – PID Function Block Setpoints 55

Table 31 – Programmable Logic Setpoints 57

Table 32 – Math Function Setpoints..... 59

Table 33 – Default Conditional Block Setpoints 60

Table 34 – Default Set-Reset Latch Block Setpoints 61

Table 35 – CAN Transmit Message Setpoints 63

Table 36 – CAN Receive Setpoints 64

Table 37 – General Diagnostics Options Setpoints..... 65

Table 38 – Diagnostic Block Setpoints 67

Table 39 – DTC React Setpoints..... 69

Figure 1 – The ECU Block Diagram 10

Figure 2 – Hotshot Digital Profile 15

Figure 3 – Analog to Digital Input 19

Figure 4 – Double Minimum and Maximum Error Thresholds 24

Figure 5 – Conditional Block Diagram 28

Figure 6 – Analog source to Digital input 39

Figure 7 – AX030780 Dimensional Drawing 40

Figure 8 – General ECU Information 43

Figure 9 – Screen Capture of J1939 Setpoints 46

Figure 10 – Screen Capture of Proportional Output Setpoints 48

Figure 11 – Screen Capture of Constant Data List Setpoints 52

Figure 12 – Screen Capture of Lookup table Setpoints 53

Figure 13 – Screen Capture of PID Blok setpoints 55

Figure 14 – Screen Capture of Programmable Logic Setpoints 56

Figure 15 – Screen Capture of Math Function Block Setpoints 58

Figure 16 – Screen Capture of Conditional Block Setpoints 60

Figure 17 – Screen Capture of Set-Reset Latch Block Setpoints 61

Figure 18 – Screen Capture of CAN Transmit Message Setpoints 62

Figure 19 – Screen Capture of CAN Receive Message Setpoints 64

Figure 20 – Screen Capture of General Diagnostics Options Setpoints 65

Figure 21 – Screen Capture of Diagnostic Block Setpoints 66

Figure 22 – TC React Setpoints 69

REFERENCES

| | |
|------------|---|
| J1939 | Recommended Practice for a Serial Control and Communications Vehicle Network, SAE, April 2011 |
| J1939/21 | Data Link Layer, SAE, December 2010 |
| J1939/71 | Vehicle Application Layer, SAE, March 2011 |
| J1939/73 | Application Layer-Diagnostics, SAE, February 2010 |
| J1939/81 | Network Management, SAE, Marc 2017 |
| TDAX030780 | Technical Datasheet, Axiomatic Technologies |
| UMAX07050x | User Manual, Axiomatic Electronic Assistant and USB-CAN, Axiomatic Technologies |

This document assumes the reader is familiar with the SAE J1939 standard. Terminology from the standard is used but not described in this document.



NOTE: This product is supported by Axiomatic Electronic Assistant V5.18.149.0 and higher.

1. OVERVIEW OF CONTROLLER

The AX030780 (Controller/ECU) is a versatile device designed to manage a wide range of output types and a single digital input. It features two proportional output channels, each capable of delivering up to 5A, as well as two analog outputs that support either $\pm 10V$ or 0-20mA signals. Additionally, it includes one digital on/off input. Thanks to its flexible circuit design, users can configure various combinations of input and output types to suit specific needs. Advanced control algorithms further enhance usability, allowing the controller to be easily programmed for diverse applications without the need for custom software development.

The Axiomatic Electronic Assistant is used to configure the Controller. Programming configurable properties, EA setpoints, are listed in chapter 4. Setpoint configuration can be saved in a file which can then be utilized to program the same configuration to another Controller. Throughout this document EA setpoint names are referred to with bolded text in double-quotes and the setpoint option is referred to with italicized text in single-quotes. For example, “**Output Type**” setpoint set to option ‘*Proportional Voltage*’.

In this document the configurable properties of the ECU are divided into function blocks, namely output function block, diagnostic function block, lookup table function block, PID Control block, programmable logic function block, math function block, CAN transmit message function block and CAN receive message function block. Input function block includes properties used to select input sensor functionality. Diagnostic function block properties are used to configure fault detection and reaction functionalities. Lookup table function blocks, programmable logic function blocks, math function blocks offer some logical programming to convert signals. The CAN transmit message function block configures properties of the messages sent to the CAN buses. And the CAN receive message function block configures properties of the messages received from the CAN buses. These function blocks are presented in detail in the next subchapters.

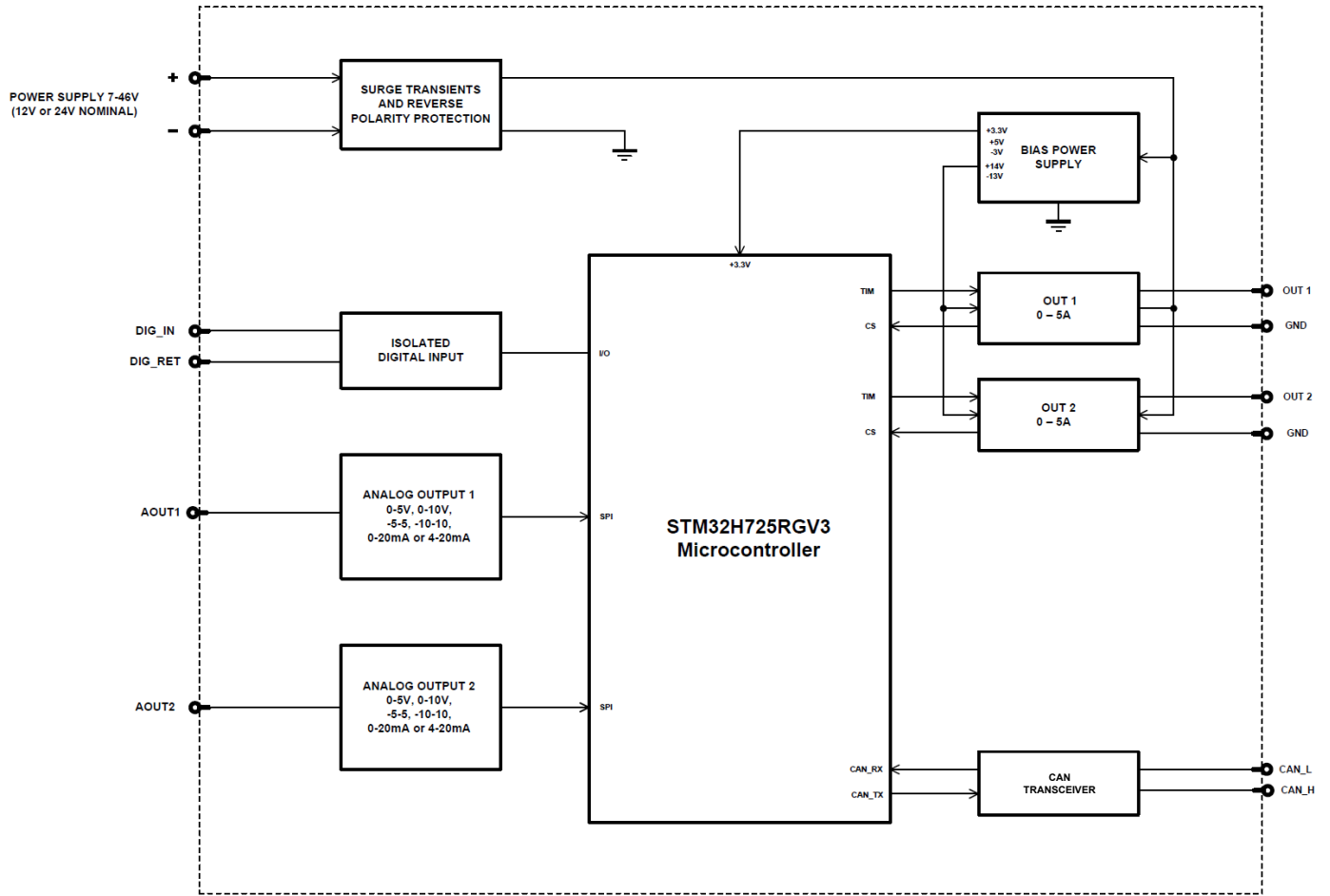

Figure 1 – The ECU Block Diagram

1.1. Digital Input Function Blocks

The controller is equipped with a total of 1 input. Input only supports Discrete Input (ON/OFF).

1.1.1. Input Polarity

In the case of Discrete Voltage Input, the options **Input Polarity** are used to configure how a signal high, or signal low is interpreted. The following table below is the available options provided. By default, *Active High* is selected.

| | |
|---|--------------------|
| 0 | <i>Active High</i> |
| 1 | <i>Active Low</i> |

Table 1 – Input Polarity

1.1.2. Discrete Input Debounce Time

The input states are sampled every 1ms. If debouncing is required, it is set by the Discrete Input Debounce Time configuration parameter. If the Discrete Input Debounce Time is zero, the discrete voltage level input is not debounced.

1.2. Proportional Output Function Blocks

The controller has altogether two Proportional Outputs. The Proportional Output is half-bridge drive with high side sourcing up to 5A. The current drawn from the output is measured to form a current feedback loop. All outputs have configurable setpoints. The Proportional Output and its setpoints are discussed in detail in the Section 4.4.

The “**Control Source**” setpoint together with “**Control Number**” setpoint determine which signal is used to drive the output. For example, setting “**Control Source**” to ‘*Universal Input Measured*’ and “**Control Number**” to ‘1’, connects signal measured from Universal Input1 to the output in question. The input signal is scaled per input type range between 0 and 1 to form control signal. Outputs respond in a linear fashion to changes in control signal.

The “**Enable Source**” setpoint together with “**Enable Number**” setpoint determine the enable signal for the output in question. The “**Enable Response**” setpoint is used to select how output will respond to the selected Enable signal. “**Enable Response**” setpoint options are listed in Table 2. If “**Enable Source**” is set to ‘*Control not used*’, the Enable signal is interpreted to be ON. If a non-digital signal is selected as Enable signal the signal is interpreted as shown in Figure 6.

Table 2 – Proportional Output Enable Response Options

| | Proportional Output Enable Response Options |
|---|--|
| 0 | Enable When On, Else Shutoff |
| 1 | Enable When On, Else Rampoff |
| 2 | Enable When On, Else Keep |
| 3 | Enable When Off, Else Shutoff |
| 4 | Enable When Off, Else Rampoff |
| 5 | Enable When Off, Else Keep |

The Override option allows the user to choose whether to drive the output with the override input engaged/disengaged, depending on the logic selected in “**Override Response.**” The options for “**Override Response**” are listed in Table 3. When override is active, the output will be driven to the value in “**Output at Override Command**” regardless of the value of the Control input.

Table 3 – Override Response Options

| | |
|---|--------------------------|
| 0 | <i>Override When ON</i> |
| 1 | <i>Override When OFF</i> |

The options for both “**Enable Source**” and “**Override Source**” are the same as the sources listed in Table 7.

*Please note that the using parameters “**Override/Enable When Off/On, Else Ramp**” are not recommended and should not be used for the Digital On/Off and Digital Hotshot.*

Another fault response which can be enabled is that of a microprocessor over-temperature or power faults automatically disabling the outputs until it has cooled back to the operating range, if the corresponding setpoint is enabled. This will be described in more detail in Section 1.6

Fault conditions are checked first, and the control signal will then be evaluated only if they are not present. If Enable, Override and Control inputs are all used, the Enable logic is evaluated first, then the Override, and lastly the Control.

“**Output Type**” setpoint options for the Proportional Output are listed in Table 4. “**Output Type**” setpoint determines what kind of signal the output produces. Changing this setpoint causes other setpoints in the group to update to match selected type, thus the “**Output Type**” should be selected before configuring other setpoints within the setpoint group.

For Proportional outputs signal minimum and maximum values are configured with “**Output At Minimum Command**” and “**Output At Maximum Command**” setpoints. Value range for both setpoints is limited by selected “**Output Type**”.

Regardless of what type of control input is selected, the output will always respond in a linear fashion to changes in the input per Equation 1.

$$y = mx + a$$

$$m = \frac{Y_{max} - Y_{min}}{X_{max} - X_{min}}$$

$$a = Y_{min} - m * X_{min}$$

Equation 1 - Linear Slope Calculations

In the case of the Output Control Logic function block, X and Y are defined as

Xmin = Control Input Minimum Ymin = “**Output at Minimum Command**”

Xmax = Control Input Maximum Ymax = “**Output at Maximum Command**”

In all cases, while X-axis has the constraint that Xmin < Xmax, there is no such limitation on the Y-axis. Thus configuring “**Output At Minimum Command**” to be greater than “**Output At Maximum Command**” allows output to follow control signal inversely.

To prevent abrupt changes at the output due to sudden changes in the command input, the user can choose to use the independent up or down ramps to smooth out the coil’s response. The “**Ramp Up**” and “**Ramp Down**” setpoints are in milliseconds, and the step size of the output change will be determined by taking the absolute value of the output range and dividing it by the ramp time.

Table 4 – Output Type Options for Proportional Output

| | |
|---|--|
| 0 | <i>Disabled</i> |
| 1 | <i>Proportional Current (0-5000mA)</i> |
| 2 | <i>Digital Hotshot (0-5000mA)</i> |
| 3 | <i>Proportional Voltage (0-Vps)</i> |
| 4 | <i>Digital On/off (0-Vps)</i> |
| 5 | <i>PWM Duty Cycle</i> |

'Proportional Current' type has associated with it two setpoints not used by other types, which are the "**Dither Frequency**" and "**Dither Amplitude**" values. The output is controlled by high frequency signal (25kHz), with the low frequency dither superimposed on top. The dither frequency will match exactly what is programmed into the setpoint, but the exact amplitude of the dither will depend on the properties of the load coil. When adjusting the dither amplitude value, select one that is high enough to ensure an immediate response to the coil to small changes in the control inputs, but not so large as to affect the accuracy or stability of the output. Refer to the coil's datasheet for more information.

The '*Proportional Voltage*' uses the measured value of the power supply and adjusts the duty cycle of the output such that the average value will match the target output voltage. Since the output is running at a high frequency (25kHz), the voltage can be easily averaged using a simple low pass filter.

The '*PWM Duty Cycle*' option allows the user to run the output at fixed frequency configure with "**PWM Output Frequency**" setpoint, while the duty cycle changes depending on the control signal.

Instead of proportional, there are also two types of digital responses possible as well. With the '*Digital On/Off*' type, should the control require the output to be on, it will be turned on at whatever the system power supply is. The output will source whatever current is required by the load, up to 3.5A.

If a digital "**Output Type**" has been selected the "**Digital Response**" setpoint will be enabled as shown in Table 5.

Table 5 – Digital Response Options

| | |
|---|-----------------------|
| 0 | <i>Normal On/Off</i> |
| 1 | <i>Inverse Logic</i> |
| 2 | <i>Latched Logic</i> |
| 3 | <i>Blinking Logic</i> |

In a '*Normal*' response, when the Control input commands the output ON, then the output will be turned ON. However, in an '*Inverse*' response, the output will be ON unless the input commands the output ON, in which case it turns OFF.

If a '*Latched*' response is selected, when the input commands the state from OFF to ON, the output will change state.

If a '*Blinking*' response is selected, then while the input commands the output ON, it will blink at the rate in the "**Output Ramp Down Time**" setpoint (when output type configured as Digital ON/OFF or Digital Hotshot, this setpoint will act as Digital Blink Rate). When commanded OFF, the output will stay off. A blinking response is only available with a '*Digital On/Off*' type of output (not a Hotshot type.)

The '*Hotshot Digital*' type is different from a simple '*Digital On/Off*' in that it still controls the current through the load. This type of output is used to turn on a coil then reduce the current so that the valve will remain open, as shown in Figure 2. Since less energy is used to keep the output engaged, this type of response is very useful to improve overall system efficiency. With this output type there are associated three setpoints: "**Hold Current**", "**Hotshot Current**" and "**Hotshot Time**" which are used to configure form of the output signal as shown in Figure 2.

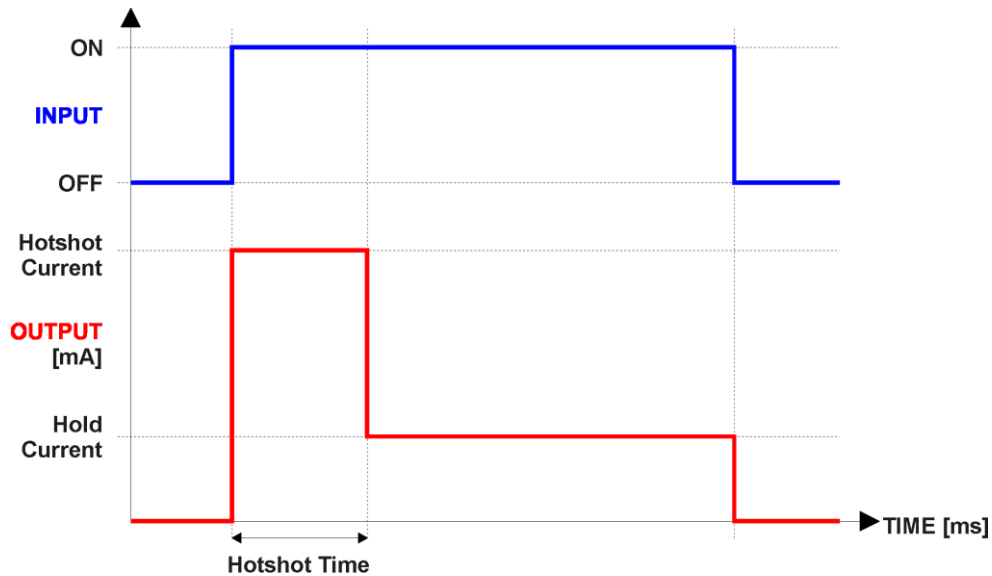

Figure 2 – Hotshot Digital Profile

Fault detection is available for current output types. A current feedback signal is measured and compared to desired output current value. Fault detection and associated setpoints are presented in section 1.6. When fault is detected, the output will respond per “**Control Fault Response**” setpoint as outlined in Table 6.

Table 6 – Fault Response Options

| | |
|---|--------------------------|
| 0 | <i>Shutoff Output</i> |
| 1 | <i>Apply Fault Value</i> |
| 2 | <i>Hold Last Value</i> |

Another fault response that can be enabled is that a power supply over voltage or under voltage will automatically disable ALL outputs. Note: this setpoint is associated with the **Power Supply Diag** function block. Also, if the **Over Temperature Diag** function block is enabled, then a microprocessor over-temperature reading disables all the outputs until it has cooled back to the operating range.

The proportional output is inherently protected against a short to GND or +Vps by circuitry. In case of a dead short, the hardware will automatically disable the output drive, regardless of what the processor is commanding for the output. When this happens, the processor detects output hardware shutdown and commands off the output in question. It will continue to drive non-short-circuited outputs normally and periodically (every 5 seconds) try to re-engage the short load, if still commanded to do so. If the fault has gone away since the last time the output was engaged while shorted, the controller will automatically resume normal operation.

In the case of an open circuit, there will be no interruption of the control for the output. The processor will continue to attempt to drive the open load.

The measured current through the load is available to be broadcasted on a CAN message if desired. It is also used as the input to the diagnostic function block for each output, and an open or shorted output can be broadcasted in a DM1 message on the CAN network.

1.3. H-Bridge Function Block

The H-Bridge Function Block combines two proportional outputs into one to provide an H-Bridge output driver. To enable it, the **“H-Bridge Enabled”** setpoint needs to be set to 1, True. In this case, both proportional outputs will be controlled by this function block.

Please note: if the **“H-Bridge Enabled”** setpoint is set to 1, True, the Proportional Output Blocks 1 and 2 will not be available for modification. However, the PID coefficients still can be modified and visible via Axiomatic Electronic Assistant tool.

The control sources, direction source, ramp up/down time, and responses are available in this function block. **“Output At Maximum/Minimum Command”** setpoints define the current output limits that can be set according to the **“Control Source”** settings. The momentary direction of the h-bridge is defined according to the **“Direction Source”**. The **“Output At Maximum/Minimum Command”** setpoints provide a bipolar range defined by the direction control source. If the range is set to 0...5000mA, it means that the possible output will vary in this range if direction is forward and -5000...0mA if the direction is backward. It is the case for the **“Override Output Value”** setpoint as well.

Please note: if **“Control Source”** or **“Direction Source”** is set to 0, ‘No Source’, the output will be disabled. Both sources should be set to any non-zero value to allow further configuration.

The control source has also an additional setting: the **“Control Response”** setpoint. It matches the one from Proportional Output Function Block. All possible options for this setpoint are shown below.

Table 7 – Control Response Options

| | |
|---|------------------------|
| 0 | Single Out Profile |
| 1 | OFF When Below Minimum |
| 2 | OFF When Above Maximum |

To control the speed of output rising or falling the **“Ramp Up/Down Time”** should be used. These setpoints define the time needed to rise the output from **“Output At Minimum Command”** to **“Output At Maximum Command”** value for the ramp up and vice versa for the ramp down. For example, if range is set to 0 to 1000mA, current output is 0mA, and the **“Ramp Up Time”** is set to 5000, the ECU will require 5s to ramp the output up to the maximum. If the current target output value is 500mA, the ECU will spend 2.5s to set it to the maximum. Both ramp up and down setpoints cannot be set to a value lower than 100ms.

Please note: the **“Ramp Up/Down Time”** setpoints are meant to ramp output in one direction per time only. If the direction is changed, the Output will drop to 0 and then will ramp up/down to a needed value. For example, if the current output’s value is 500mA and the direction is backward (the actual output is -500mA), at the direction change, the output will drop to 0mA and only after that will ramp up to a 500mA (or to any new commanded value).

The **“Enable Source”**, and **“Override Source”** setpoints match the functionality of the Proportional Output Function Block and are shown in the Section 1.1.

The **“Enable Response”** setpoint has the same configuration options as Proportional Output block. However, options ‘Enable When ON Else Shutoff’ and ‘Enable When OFF Else Shutoff’ are not recommended to be used since they will rapidly reset output to 0mA.

1.4. Analog Output

The controller has 2 analog outputs that can be configured and they are inherently independent of each other. The “**Output Type**” parameter determines what kind of signal the output produces. Changing this parameter will update other parameters in the group to match the selected type. For this reason, it should be the first parameter to be changed. The supported output types by the controller are listed in Table 1 below. By default, outputs are configured as ‘1, Analog Voltage’ type.

| Value | Meaning |
|-------|-----------------|
| 0 | Output Not Used |
| 1 | Analog Voltage |
| 2 | Analog Current |

Table 8 – Analog Output Type Options

The control signal of the outputs will have associated with it a minimum and maximum values. Besides type ‘*Digital ON/OFF*’, all the other output types are always responding in a linear fashion to changes in the control source per the calculation in Equation 2

$$y = mx + a$$

$$m = \frac{Y_{\max} - Y_{\min}}{X_{\max} - X_{\min}}$$

$$a = Y_{\min} - m * X_{\min}$$

Equation 2 - Linear Slope Calculations

Where X and Y are defined as:

X_{\min} = Control Input Minimum

Y_{\min} = “**Output At Minimum Command**”

X_{\max} = Control Input Maximum

Y_{\max} = “**Output At Maximum Command**”

In all cases, while the X-axis has the constraint that $X_{\min} < X_{\max}$, there is no such limitation on the Y-axis. This allows for a negative slope so that as the control input signal increases, the target output value decreases. Or it allows output to follow control signal inversely.

1.4.1. Analog Current/Voltage

Current Outputs can be configured to different ranges as 0-20mA, 4-20mA and Voltage Outputs can be configured to 0-5V, 0-10V, +/-5V and +/-10V. Simply setting the “**Output at Minimum Command**” and “**Output at Maximum Command**” to corresponding value in each range will drive the output to different range options. The unit of measurement for current output variables is milliamps [mA] and volts [V] for voltage outputs.

1.4.2. Digital ON/OFF

The “Digital Type VPS range” setpoint determines if the output is at +5V when ON. If a non-digital control is selected for this type, the command state will be OFF at or below the minimum input, ON at or above the maximum input, and it will not change between those points. In other words, the input has its built-in hysteresis, as shown in Figure 3. This relationship is true for any function block that has a non-digital input mapped to digital control.

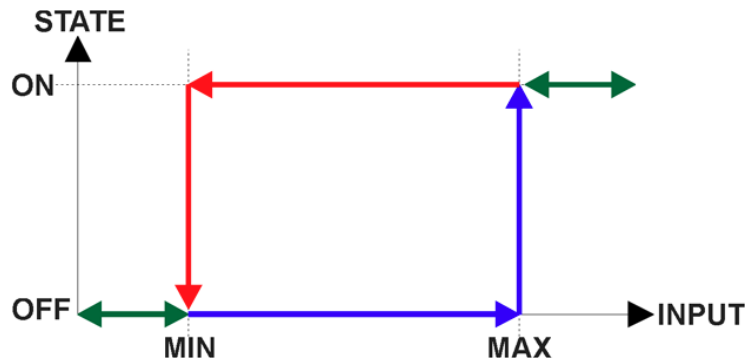

Figure 3 – Analog to Digital Input

1.4.3. Common Parameters

In order to prevent abrupt changes at the output due to sudden changes in the command input, the user can choose to use the independent up or down ramps to smooth out the response. The “**Ramp Up (Min to Max)**” and “**Ramp Down (Max to Min)**” parameters are in milliseconds, and the step size of the output change will be determined by taking the absolute value of the output range and dividing it by the ramp time. However, these setpoints are set to zero by default since in most signal conversion applications, fast response times are desired.

By default, the “**Control Source**” is setup to be ‘*CAN Receive Message*’. In other words, all the outputs will respond in a linear fashion to the corresponding CAN received command data.

The “**Control Source**” together with “**Control Number**” parameter determine which signal is used to drive the output. For example, setting “**Control Source**” to ‘*CAN Receive Message*’ and “**Control Number**” to ‘1’ will connect signal measured from CAN Receive 1 to the output in question. The options for “**Control Sources**” and available “**Control Number**” are listed in Table 23.

In addition to the Control input, the function block also supports an enable input which can be setup as either an enable or disable signal.

When an Enable input is used, the Analog Output will follow the ‘**Analog Output Enable Response**’ in Table 9.

| Analog Output Enable Response Options | |
|---------------------------------------|----------------------------------|
| 0 | Enable When on Else Shutoff |
| 1 | Enable When on Else Rampoff |
| 2 | Enable When on Else Ramp to Min |
| 3 | Enable When on Else Ramp to Max |
| 4 | Enable When on Else Keep Last |
| 5 | Enable When off Else Shutoff |
| 6 | Enable When off Else Rampoff |
| 7 | Enable When off Else Ramp to Min |
| 8 | Enable When off Else Ramp to Max |
| 9 | Enable When off Else Keep Last |

Table 9 – Analog Output Enable Response Options

The Override option allows the user to choose whether or not to drive the output with the override input being engaged/disengaged, depending on the logic selected in “**Override Response.**” The options for “**Override Response**” listed in Table 7. When override is active, the output will be driven to the value in “**Output at Override Command**” regardless of the value of the Control input.

| Value | Meaning |
|-------|-------------------|
| 0 | Override When ON |
| 1 | Override When OFF |

Table 10 – Override Response Options

The options for both “**Enable Source**” and “**Override Source**” are same as sources listed in Table 23.

Another fault response that can be enabled is that a power supply fault (under/over voltage) will automatically disable the outputs. Note: this setpoint is associated with the **Under Voltage Diagnostics** and Over **Voltage Diagnostics blocks**. Also, a microprocessor over-temperature fault can be used to disable all the outputs until it has cooled back to the operating range if the corresponding setpoints is enabled. These will be described in more details in Section 1.6.

1.5. PID Control Function Block

The PID Control function block is an independent logic block, but it is normally intended to be associated with proportional output control blocks described in the chapters before. When the Control Source for an output has been setup as a PID Function Block, the command from the selected PID block drives the physical output on the motor controller unit.

To enable the PID Control function the “PID Enabled” setpoint should be set to ‘1, True’. The “Target Source” and “Target Number” setpoints determine control input and the “Feedback Source” and “Feedback Number” setpoints determine the established feedback signal to the PID Control function block. The “Control Response” will use the selected inputs as per the options listed in Table 11. When active, the PID algorithm will be called every “Cycle Time” in milliseconds.

Table 11 – PID Response Options

| | |
|---|----------------------|
| 0 | Single Output |
| 1 | Setpoint Control |
| 2 | On When Over Target |
| 3 | On When Below Target |

When a ‘Single Output’ response is selected, the Target and Feedback inputs do not have to share the same units. In both cases, the signals are converted to a percentage value based on the minimum and maximum values associated with the source function block.

For example, a CAN command could be used to set the target value, in which case it would be converted to a percentage value using “Data Minimum” and “Data Maximum” setpoints in the appropriate CAN Receive X function block. The closed-loop feedback signal, i.e. a Current Feedback from the proportional current output, could be selected as the feedback source. In this case the value of the input would be converted to a percentage based on the “Output Data Min” and “Output Data Max” setpoints in the output block. The output of the PID function would depend on the difference between the commanded target and the measured feedback as a percentage of each signals range. In this mode, the output of the block would be a value from 0 to 100%.

In Order to allow the output to stabilize, the user can select a non-zero value for “Output Tolerance”. If the absolute value of ErrorK is less than this value, ErrorK in the formula below will be set to zero.

The PID algorithm used is shown below, where G, Ki, Ti, Kd, Td and Loop_Update_Rate are configurable parameters.

$$PIDOutput_k = P_k + I_k + D_k$$

$$\begin{aligned}P_k &= P_Gain * Error_k \\I_k &= I_Gain * ErrorSum_k \\D_k &= D_Gain * (Error_k - Error_{k-1})\end{aligned}$$

$$\begin{aligned}Error_k &= Target - Feedback \\ErrorSum_k &= ErrorSum_{k-1} + Error_k\end{aligned}$$

$$\begin{aligned}P_Gain &= G \\I_Gain &= G * Ki * T/Ti \text{ (Note: If Ti is zero, I_Gain = 0)} \\D_Gain &= G * Kd * Td/T\end{aligned}$$

$$T = Loop_Update_Rate * 0.001$$

Please Note: Each system will have to be tuned for the optimum output response. Response times, overshoots and other variables will have to be decided by the customer using an appropriate PID tuning strategy. Axiomatic is not responsible for tuning the control system.

1.6. Diagnostic Function Blocks

This ECU supports diagnostic messaging. DM1 message is a message, containing Active Diagnostic Trouble Codes (DTC) that is sent to the J1939 network in case a fault has been detected. A Diagnostic Trouble Code is defined by the J1939 standard as a four byte value which is a combination of:

| | | |
|-----|--------------------------|--|
| SPN | Suspect Parameter Number | (User defined) |
| FMI | Failure Mode Identifier | (See Table 14) |
| CM | Conversion Method | (Always set to 0) |
| OC | Occurrence Count | (Number of times the fault has happened) |

In addition to supporting the DM1 message, Interface Module Input also supports:

| | | |
|------|---|----------------------|
| DM2 | Previously Active Diagnostic Trouble Codes | Sent only on request |
| DM3 | Diagnostic Data Clear/Reset of Previously Active DTCs | Done only on request |
| DM11 | Diagnostic Data Clear/Reset for Active DTCs | Done only on request |

Fault detection and reaction is a standalone functionality that can be configured to monitor and report diagnostics of various controller parameters. The Interface Module supports 16 Diagnostics Definitions, each freely configurable by the user.

There are 4 fault types that can be used, “**Minimum and maximum error**”, “**Absolute value error**”, “**State error**” and “**Double minimum and maximum error**”.

Minimum and maximum error has two thresholds, “MIN Shutdown” and “MAX Shutdown” that have configurable, independent diagnostics parameters (SPN, FMI, Generate DTCs, delay before flagging status). In case the parameter to monitor stays between these two thresholds, the diagnostic is not flagged.

Absolute value error has one configurable threshold with configurable parameters. In case the parameter to monitor stays below this threshold, the diagnostic is not flagged.

State error is similar to the Absolute value error, the only difference is that State error does not allow the user to specify specific threshold values; thresholds ‘1’ and ‘0’ are used instead. This is ideal for monitoring state information, such as received message timeouts.

Double minimum and maximum error lets user to specify four thresholds, each with independent diagnostic parameters. The diagnostic status and threshold values is determined and expected as show in Figure 4 below.

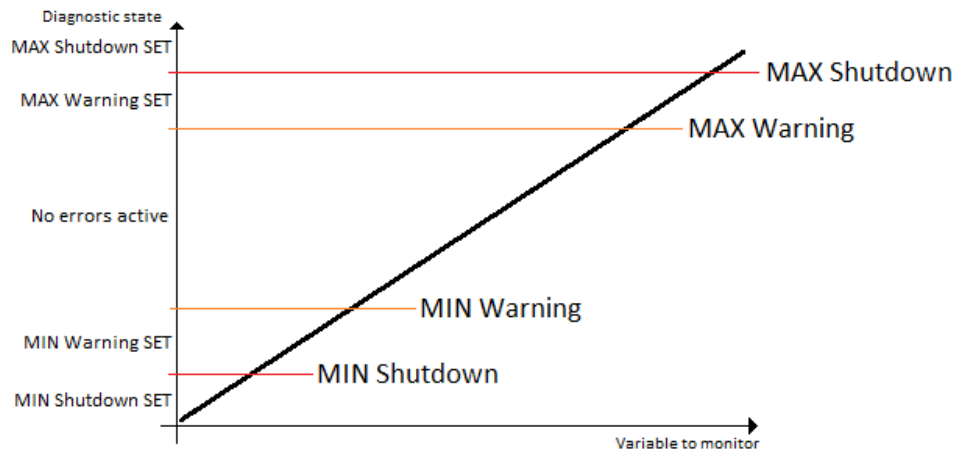

Figure 4 – Double Minimum and Maximum Error Thresholds

In case any of the Diagnostics blocks is configured to monitor Output Current Feedback, there is an internal error status flag maintained automatically for that particular output. This internal flag can be used for driving the particular output to a specified state in case of diagnostic event using Proportional Current Output setpoints “Control Fault Response”, “Output in Fault Mode” and “Fault Detection Enabled”.

There is also built in error status flags for power supply and CPU temperature monitoring. In case any of the diagnostics blocks is measuring these two parameters, the corresponding internal error status flags can be used for shutting down the unit in case of failure. The setpoints “**Power Fault Disables Outputs**” and “**Over Temperature Shutdown**” can be used for enabling the shutdown of the unit (shutdown == output driving is turned off).

While there are no active DTCs, the Interface Module will send “No Active Faults” message. If a previously inactive DTC becomes active, a DM1 will be sent immediately to reflect this. As soon as the last active DTC goes inactive, a DM1 indicating that there are no more active DTCs will be sent.

If there is more than one active DTC at any given time, the regular DM1 message will be sent using a multipacket message to the Requester Address using the Transport Protocol (TP).



At power up, the DM1 message will not be broadcasted until after 5 second delay. This is done to prevent any power up or initialization conditions from being flagged as an active error on the network.

When the fault is linked to a DTC, a non-volatile log of the occurrence count (OC) is kept. As soon as the controller detects a new (previously inactive) fault, it will start decrementing the “**Delay before Event is flagged**” timer for that Diagnostic function block. If the fault has remained present during the delay time, then the controller will set the DTC to active, and will increment the OC in the log. A DM1 will immediately be generated that includes the new DTC. The timer is provided so that intermittent faults do not overwhelm the network as the fault comes and goes, since a DM1 message would be sent every time the fault shows up or goes away.

By default, the fault flag is cleared when error condition that has caused it goes away. The DTC is made Previously Active and is it is no longer included in the DM1 message. To identify a fault having happened, even if the condition that has caused is one away, the “**Event Cleared only by DM11**” setpoint can be set to ‘True’. This configuration enables DTC to stay Active, even after the fault flag has been cleared, and be included in DM1 message until a Diagnostic Data Clear/Reset for Active DTCs (DM11) has been requested.

As defined by J1939 Standard the first byte of the DM1 message reflects the Lamp status. “**Lamp Set by Event**” setpoint determines the lamp type set in this byte of DTC. “**Lamp Set by Event**” setpoint options are listed in Table 12. By default, the ‘Amber, Warning’ lamp is typically the one set be any active fault.

Table 12 – Lamp Set by Event in DM1 Options

| | |
|---|----------------------|
| 0 | <i>Protect</i> |
| 1 | <i>Amber Warning</i> |
| 2 | <i>Red Stop</i> |
| 3 | <i>Malfunction</i> |

“**SPN for Event**” defines suspect parameter number used as part of DTC. The default value zero is not allowed by the standard, thus no DM will be sent unless “**SPN for Event**” is configured to be different from zero. **It is the user’s responsibility to select SPN that will not violate J1939 standard.** When the “**SPN for Event**” is changed, the OC of the associated error log is automatically reset to zero.

Table 13 – FMI for Event Options

| | |
|----|--|
| 0 | <i>Data Valid But Above Normal Operational Range - Most Severe Level</i> |
| 1 | <i>Data Valid But Below Normal Operational Range - Most Severe Level</i> |
| 2 | <i>Data Intermittent</i> |
| 3 | <i>Voltage Above Normal, Or Shorted To High Source</i> |
| 4 | <i>Voltage Below Normal, Or Shorted To Low Source</i> |
| 5 | <i>Current Below Normal Or Open Circuit</i> |
| 6 | <i>Current Above Normal Or Grounded Circuit</i> |
| 7 | <i>Mechanical Error</i> |
| 8 | <i>Abnormal Frequency Or Pulse Width Or Period</i> |
| 9 | <i>Abnormal Update Rate</i> |
| 10 | <i>Abnormal Rate Of Change</i> |
| 11 | <i>Root Cause Not Known</i> |
| 12 | <i>Bad Component</i> |
| 13 | <i>Out Of Calibration</i> |
| 14 | <i>Special Instructions</i> |
| 15 | <i>Data Valid But Above Normal Operating Range – Least Severe Level</i> |
| 16 | <i>Data Valid But Above Normal Operating Range – Moderately Severe Level</i> |
| 17 | <i>Data Valid But Below Normal Operating Range – Least Severe Level</i> |
| 18 | <i>Data Valid But Below Normal Operating Range – Moderately Severe Level</i> |
| 19 | <i>Network Error</i> |
| 20 | <i>Data Drifted High</i> |
| 21 | <i>Data Drifted Low</i> |
| 31 | <i>Condition Exists</i> |

Every fault has associated a default FMI with them. The used FMI can be configured with “**FMI for Event**” setpoint, presented in Table 13. When an FMI is selected from Low Fault FMIs in Table 14 for a fault that can be flagged either high or low occurrence, it is recommended that the user would select the high occurrence FMI from the right column of Table 14. There is no automatic setting of High and Low FMIs in the firmware, the user can configure these freely.

Table 14 – Low Fault FMIs and corresponding High Fault FMIs

| Low Fault FMIs | High Fault FMIs |
|--|--|
| <i>FMI=1, Data Valid But Below Normal Operation Range – Most Severe Level</i> | <i>FMI=0, Data Valid But Above Normal Operational Range – Most Severe Level</i> |
| <i>FMI=4, Voltage Below Normal, Or Shorted to Low Source</i> | <i>FMI=3, Voltage Above Normal, Or Shorted To High Source</i> |
| <i>FMI=5, Current Below Normal Or Open Circuit</i> | <i>FMI=6, Current Above Normal Or Grounded Circuit</i> |
| <i>FMI=17, Data Valid But Below Normal Operating Range – Least Severe Level</i> | <i>FMI=15, Data Valid But Above Normal Operating Range – Least Severe Level</i> |
| <i>FMI=18, Data Valid But Below Normal Operating Level – Moderately Severe Level</i> | <i>FMI=16, Data Valid But Above Normal Operating Range – Moderately Severe Level</i> |
| <i>FMI=21, Data Drifted Low</i> | <i>FMI=20, Data Drifted High</i> |

1.7. Math Function Block

There are five mathematical function blocks that allow the user to define basic algorithms. A math function block can take up to six input signals. Each input is then scaled according to the associated limit and scaling setpoints.

Inputs are converted into percentage value based on the “Input X Minimum” and “Input X Maximum” values selected. For additional control the user can also adjust the “Input X Gain” setpoint to increase the resolution of the input data and the min and max values.

A mathematical function block includes three selectable functions, in which each implements equation A operator B, where A and B are function inputs and operator is function selected with a setpoint “Math Function X”. Setpoint options are presented in Table 15. The functions are connected together, so that result of the preceding function goes into Input A of the next function. Thus Function 1 has both Input A and Input B selectable with setpoints, where Functions 2 to 4 have only Input B selectable. Input is selected by setting “Function X Input Y Source” and “Function X Input Y Number”. If “Function X Input B Source” is set to 0 ‘Control not used’ signal goes through function unchanged.

$$\text{Math Block Output} = \left(\left((A1 \text{ op1 } B1) \text{ op2 } B2 \right) \text{ op3 } B3 \right) \text{ op4 } B4$$

Table 15 – Math function X Operator Options

| | |
|----|--|
| 0 | =, True when InA equals InB |
| 1 | !=, True when InA not equal InB |
| 2 | >, True when InA greater than InB |
| 3 | >=, True when InA greater than or equal InB |
| 4 | <, True when InA less than InB |
| 5 | <=, True when InA less than or equal InB |
| 6 | OR, True when InA or InB is True |
| 7 | AND, True when InA and InB are True |
| 8 | XOR, True when either InA or InB is True, but not both |
| 9 | +, Result = InA plus InB |
| 10 | -, Result = InA minus InB |
| 11 | x, Result = InA times InB |
| 12 | /, Result = InA divided by InB |
| 13 | MIN, Result = Smallest of InA and InB |
| 14 | MAX, Result = Largest of InA and InB |

For logic operations (6, 7, and 8) scaled input greater than or equal to 1 is treated as TRUE. For logic operations (0 to 8), the result of the function will always be 0 (FALSE) or 1 (TRUE). For the arithmetic functions (9 to 14), it is recommended to scale the data such that the resulting operation will not exceed full scale (0 to 100%) and saturate the output result.

When dividing, a zero divider will always result in a 100% output value for the associated function.

Lastly the resulting mathematical calculation, presented as a percentage value, can be scaled into the appropriate physical units using the “Math Output Minimum Range” and “Math Output Maximum Range” setpoints. These values are also used as the limits when the Math Function is selected as the input source for another function block.

1.8. Conditional Block

The Conditional Block compares up to four different input sources with different logical or relational operators. The result of each block can therefore only be true (1) or false (0). Figure 5 demonstrates the connections between all parameters.

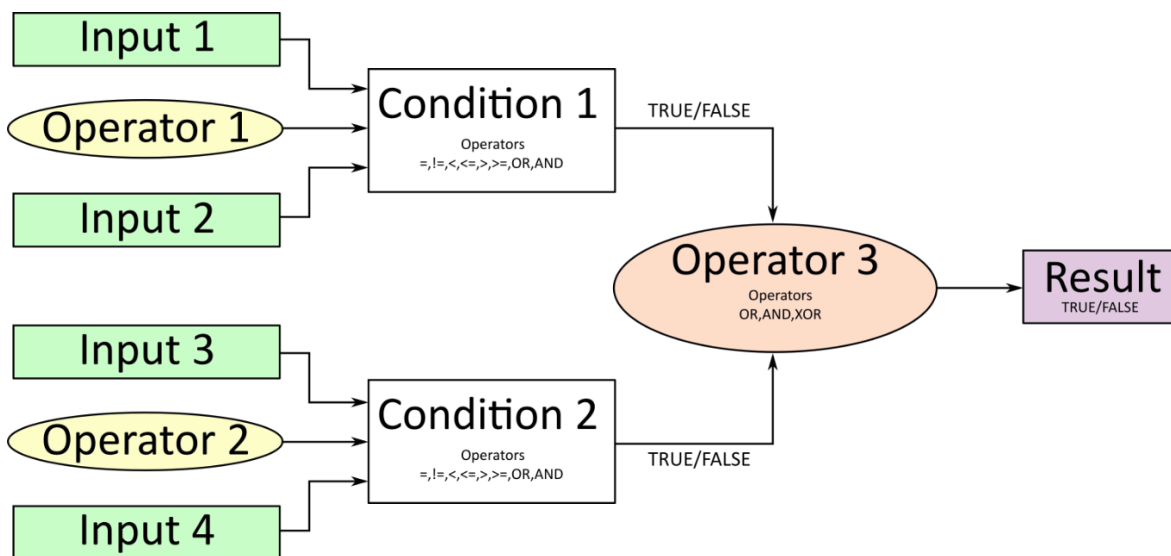

Figure 5 – Conditional Block Diagram

Each Conditional Block offers two conditions. Both compare two inputs, which can hold a logical value or an integer value. The output of the conditions can only be true or false and will be compared by Operator 3 with a logical operator. This comparison is the result of the Conditional Block and can control any output source.

Value of each source will then be compared to each other with an operator of Table 16. If no source is selected, the output value of an Input will be zero.

Table 16 – Input Operator Options

| Value | Meaning |
|-------|---|
| 0 | ==, True when Argument 1 is equal to Argument 2 |
| 1 | !=, True when Argument 1 is not equal to Argument 2 |
| 2 | >, True when Argument 1 is greater than Argument 2 |
| 3 | >=, True when Argument 1 is greater than Argument 2 |
| 4 | <, True when Argument 1 is less than Argument 2 |
| 5 | <=, True when Argument 1 is less than or equal Argument 2 |
| 6 | OR, True when Argument 1 or Argument 2 is True |
| 7 | AND, True when Argument 1 and Argument 2 are True |

Operator 1 and Operator 2 are configured to OR by default. The table above cannot be used for comparing the conditions because they can only be compared with logical operators, which are listed in

Table 17.

Table 17 – Condition Operator Options

| Value | Meaning |
|-------|--|
| 0 | OR, True when Argument 1 or Argument 2 is True |
| 1 | AND, True when Argument 1 and Argument 2 are True |
| 2 | XOR, True when Argument 1 is not equal to Argument 2 |

If only one condition is used, it is to make sure that Operator 3 is set to OR so that the result is based solely on the condition which has been chosen.

1.9. Set / Reset Latch Function Block

Set-Reset Block consists of only 2 control sources: Reset Source and Set Source. The purpose of these blocks is to simulate a modified latching function in which the 'Reset Signal' has more precedence. The 'latching' function works as per the Table 18 below.

Table 18 – Set-Reset Function block operation.

| 'Set Signal' | 'Reset Signal' | 'Set-Reset Block Output' (Initial State: OFF) |
|--------------|----------------|--|
| OFF | OFF | Latched State |
| OFF | ON | OFF |
| ON | OFF | ON |
| ON | ON | OFF |

The Reset and Set sources have associated with them a minimum and maximum threshold values which determine the ON and OFF state. For the Reset Source are Reset Minimum Threshold and Reset Maximum Threshold. Similarly, for the Set Source are Set Minimum Threshold and Set Maximum Threshold. These setpoints also allow to have a dead band in between ON/OFF states and they are in terms of percentage of input selected.

As seen in Table 18 above, the 'Reset Signal' has more precedence over the 'Set Signal' - if the state of 'Reset Signal' is ON, the state of 'Set-Reset Block Output' will be OFF. To create an ON state in 'Set-Reset Block Output' the state of 'Reset Signal' must be OFF while the state of 'Set Signal' is ON. In this case, the state of 'Set-Reset Block Output' will remain ON even if 'Set Signal' turns OFF as long as 'Reset Signal' remains OFF. As soon as the 'Reset Signal' turns ON the 'Set-Reset Block Output' will turn OFF regardless of the state of 'Set Signal'.

1.10. Lookup Table Function Block

Lookup Tables are used to give output response up to 10 slopes per input. If more than 10 slopes are required, A Programmable Logic Block can be used to combine up to three tables to get 30 slopes as described in 1.11.

Lookup tables have two differing modes defined by “X-Axis Type” setpoint, given in Table 19. Option ‘0 – Data Response’ is the normal mode where block input signal is selected with the “X-Axis Source” and “X-Axis Number” setpoints and X values present directly input signal values. With option ‘1 – Time Response’ the input signal is time and X values present time in milliseconds. And selected input signal is used as digital enable.

Table 19 – X-Axis Type Options

| | |
|---|---------------|
| 0 | Data Response |
| 1 | Time Response |

The slopes are defined with (x, y) points and associated point response. X value presents input signal value and Y value corresponding Lookup Table output value. “PointN – Response” setpoint defines type of the slope from preceding point to the point in question. Response options are given in Table 20. ‘Ramp To’ gives a linearized slope between points, whereas ‘Jump to’ gives a point to point response, where any input value between XN-1 and XN will result Lookup Table output being YN. “Point0 – Response” is always ‘Jump To’ and cannot be edited. Choosing ‘Ignored’ response causes associated point and all the following points to be ignored.

Table 20 – PointN – Response Options

| | |
|---|---------|
| 0 | Ignore |
| 1 | Ramp To |
| 2 | Jump To |

The X values are limited by minimum and maximum range of the selected input source if the source is a Math Function Block. For the fore mentioned sources X-Axis data will be redefined when ranges are changed, therefore inputs should be adjusted before changing X-Axis values. For other sources Xmin and Xmax are -100000 and 1000000. The X-Axis is constraint to be in rising order, thus value of the next index is greater than or equal to preceding one. Therefore, when adjusting the X-Axis data, it is recommended that X10 is changed first, then lower indexes in descending order.

$$X_{min} \leq X_0 \leq X_1 \leq X_2 \leq X_3 \leq X_4 \leq X_5 \leq X_6 \leq X_7 \leq X_8 \leq X_9 \leq X_{10} \leq X_{max}$$

The Y-Axis has no constraints on the data it presents, thus inverse, decreasing, increasing or other response can be easily established. The Smallest of the Y-Axis values is used as Lookup Table output min and the largest of the Y-Axis values is used as Lookup Table output max (i.e. used as Xmin and Xmax values in linear calculation.). Ignored points are not considered for min and max values.

1.11. Programmable Logic Function Block

The Programmable Logic Function Block is a powerful tool. Programmable Logic can be linked to up to three Lookup Tables, any of which would be selected only under given conditions. Thus, the output of a Programmable Logic at any given time will be the output of the Lookup Table selected by the defined logic. Therefore, up to three different responses to the same input, or three different responses to different inputs, can become the input to another function block.

In order to enable any one of the Programmable Logic blocks, the “Logic Enabled” setpoint must be set to ‘True’. By default, all Logic blocks are disabled.

The three associated tables are selected by setting “Table Number X” setpoint to desired Lookup Table number, for example selecting 1 would set Lookup Table 1 as TableX.

For each TableX there are three conditions that define the logic to select the associated Lookup Table as Logic output. Each condition implements function $Argument1 \text{ Operator } Argument2$ where Operator is logical operator defined by setpoint “Table X – Condition Y Operator”. Setpoint options are listed in Table 21. Condition arguments are selected with “Table X – Condition Y Argument Z Source” and “Table X – Condition Y Argument Z Number” setpoints. If ‘0 – Control not Used’ option is selected as “Table x – Condition Y Argument Z Source” the argument is interpreted as 0.

Table 21 – Table X – Condition Y Operator Options

| | |
|---|---------------------------|
| 0 | =, Equal |
| 1 | !=, Not Equal |
| 2 | >, Greater Than |
| 3 | >=, Greater Than or Equal |
| 4 | <, Less Than |
| 5 | <=, Less Than or Equal |

The three conditions are evaluated and if the result satisfies logical operation defined with “Logical Operator X” setpoint, given in Table 22, the associated Lookup Table is selected as output of the Logical block. Option ‘0 – Default Table’ selects associated Lookup Table in all conditions.

Table 22 – Table X – Conditions Logical Operator Options

| | |
|---|-------------------------|
| 0 | Default Table (Table1) |
| 1 | Cnd1 And Cnd2 And Cnd3 |
| 2 | Cnd1 Or Cnd2 Or Cnd3 |
| 3 | (Cnd1 And Cnd2) Or Cnd3 |
| 4 | (Cnd1 Or Cnd2) And Cnd3 |

The three logical operations are evaluated in order and the first to satisfy gets selected, thus if Table1 logical operation is satisfied, the Lookup Table associated with Table1 gets selected regardless of two other logical operations. In addition, if none of the logical operations is satisfied the Lookup Table associated with Table1 gets selected.

1.12. Constant Data

The Constant Data Block contains 2 fixed (False/True) and 13 configurable constant data setpoints which can be used as a control source for other functions. While they are available as a control source to all functions, it is recommended not to use constant data as a control source for the Set-Reset Latch Block.

1.13. DTC React

DTC React is a function block that allows the ECU to receive and process the DM1 messages. There are 16 separated function blocks that can capture up to 16 different DM1 messages. Each DTC React has two mandatory and 2 optional parameters. The mandatory parameters are the SPN and FMI. If only these parameters are used, the output will be set to high if the DM1 message with the combination of selected SPN and FMI. The state will remain high for five seconds and will be set if the DM1 message will be received again.

Among optional parameters there are lamp setting and the source address. To enable them, the “**Lamp Used to Trigger Reaction**” and “**Source Address Used to Trigger Reaction**” should be set to 1, *True*. In this case, beside SPN and FMI the ECU will compare the Lamp Setting and/or Source Address of the received message.

The exceptions are the following SPN:

- SPN 1213 and Lamp Status 0x40;
- SPN623 and Lamp Status 0x10;
- SPN624 and Lamp Status 0x04;
- SPN624 and Lamp Status 0x01;

In case if the SPNs above are chosen, the DTC React function block will set the output to HIGH if SPN and Lamp Status matches even if FMI doesn't match. However, if the “**Source Address Used to Trigger Reaction**” is set to 1, *True* and selected address doesn't match, the DTC React output will be set to FALSE.

1.14. CAN Transmit Message Function Block

The CAN Transmit function block is used to send any output from another function block (i.e. input, CAN receive) to the J1939 network. The AX030780 ECU has 10 CAN Transmit Messages and each message has 10 completely user defined signals.

1.14.1. CAN Transmit Message Setpoints

Each CAN Transmit Message setpoint group includes setpoints that effect the whole message and are thus mutual for all signals of the message. These setpoints are presented in this section. The setpoints that configure an individual signal are presented in next section.

The “**Transmit PGN**” setpoint sets PGN used with the message. **User should be familiar with the SAE J1939 standard, and select values for PGN/SPN combinations as appropriate from section J1939/71.**

“**Repetition Rate**” setpoint defines the interval used to send the message to the J1939 network. If the “**Repetition Rate**” is set to zero, the message is disabled unless it shares its PGN with another message. In case of a shared PGN repetition rate of the LOWEST numbered message are used to send the message ‘bundle’.



At power up, transmitted message will not be broadcasted until after a 5 second delay. This is done to prevent any power up or initialization conditions from creating problems on the network.

By default, all messages are sent on Proprietary B PGNs as broadcast messages. Thus “**Transmit Message Priority**” is always initialized to 6 (low priority) and the “**Destination Address**” setpoint is not used. This setpoint is only valid when a PDU1 PGN has been selected, and it can be set either to the Global Address (0xFF) for broadcasts, or sent to a specific address as setup by the user.

1.14.2. CAN Transmit Signal Setpoints

Each CAN transmit message has four associated signals, which define data inside the Transmit message. “**Control Source**” setpoint together with “**Control Number**” setpoint define the signal source of the message. “**Control Source**” and “**Control Number**” options are listed in Table 23. Setting “**Control Source**” to ‘*Control Not Used*’ disables the signal.

“**Transmit Data Size**” setpoint determines how many bits signal reserves from the message. “**Signal X Byte Index**” determines in which of 8 bytes of the CAN message LSB of the signal is located. Similarly “**Signal X Bit Index**” determines in which of 8 bits of a byte the LSB is located. These setpoints are freely configurable, thus **it is the user’s responsibility to ensure that signals do not overlap and mask each other.**

“Signal X Resolution” setpoint determines the scaling done on the signal data before it is sent to the bus. “Signal X Offset” setpoint determines the value that is subtracted from the signal data before it is scaled. Offset and Resolution are interpreted in units of the selected source signal.

1.15. CAN Receive Function Block

The CAN Receive function block is designed to take any SPN from the J1939 network, and use it as an input to another function block (i.e. Outputs).

“**CAN Interface**” setpoint is used to define from which of the two CAN Interfaces the message in question is received.

The “**Signal Type**” is the most important setpoint associated with this function block and it should be selected first.

Once a message has been set to Discrete/Continuous, a Lost Communication fault will be flagged if that message is not received off the bus within the “**Receive Message Timeout**” period. This could trigger a Lost Communication event as described in section 1.6. In order to avoid timeouts on a heavily saturated network, it is recommended to set the period at least three times longer than the expected update rate. To disable the timeout feature, simply set this value to zero, in which case the received message will never trigger a Lost Communication fault.

By default, all control messages are expected to be sent to the Interface Module on Proprietary B PGNs. However, should a PDU1 message be selected, the Interface Module can be setup to receive it from any ECU by setting the “**Specific Address that sends the PGN**” to the Global Address (0xFF). If a specific address is selected instead, then any other ECU data on the PGN will be ignored.

The “**Receive Data Size**”, “**Receive Data Index in Array (LSB)**”, “**Receive Bit Index in Byte (LSB)**”, “**Receive Resolution**” and “**Receive Offset**” can all be used to map any SPN supported by the J1939 standard to the output data of the Received function block.

As mentioned earlier, a CAN receive function clock can be selected as the source of the control input for the output function blocks. When this is the case, the “**Received Data Min (Off Threshold)**” and “**Received Data Max (On Threshold)**” setpoints determine the minimum and maximum values of the control signal. As the names imply, they are also used as the On/Off thresholds for digital output types. These values are in whatever units the data is AFTER the resolution and offset is applied to CAN receive signal.

The Controller supports up to ten unique CAN Receive Messages. Default setpoint values are listed in section 4.15.

1.16. Available Control Sources

Many of the Function Blocks have selectable input signals, which are determined with “[Name] Source” and “[Name] Number” setpoints. Together, these setpoints uniquely select how the I/O of the various function blocks are linked together. “[Name] Source” setpoint determines the type of the source and “[Name] Number” selects the actual source if there is more than one of the same type. Available “[Name] Source” options and associated “[Name] Number” ranges are listed in Table 23. All sources, except “CAN message reception timeout”, are available for all blocks, including output control blocks and CAN Transmit messages. Thought input Sources are freely selectable, not all options would make sense for any particular input, and it is up to the user to program the controller in a logical and functional manner.

Table 23 – Available Control Sources and Numbers

| Control Source | Number Range | Notes |
|---|--------------|--|
| <i>0: Control Not Used</i> | N/A | When this is selected, it disables all other setpoints associated with the signal in question. |
| <i>1: Received CAN Message</i> | 1 to 10 | |
| <i>2: Lookup Table</i> | 1 to 10 | |
| <i>3: Programmable Logic</i> | 1 to 4 | |
| <i>4: Math Logic</i> | 1 to 5 | |
| <i>5: Conditional Logic</i> | 1 to 10 | |
| <i>6: Set-Reset Latch</i> | 1 to 5 | |
| <i>7: Constant Data</i> | 1 to 15 | |
| <i>8: DTC React</i> | 1 to 16 | |
| <i>9: Power Supply Measured</i> | 0 to 255 | Measured power supply value in Volts. The Parameter sets the threshold in Volts to compare with. |
| <i>10: Processor Temperature Measured</i> | 0 to 255 | Measured processor temperature in °C. The Parameter sets the threshold in Celsius to compare with. |
| <i>11: PID Block</i> | 1 to 2 | |
| <i>12: Output Target Value</i> | 1 to 2 | |
| <i>13: Output Current Feedback</i> | N/A | Measured Feedback current from the proportional output in mA, used in Output Diagnostics. |
| <i>14: CAN Reception Timeout</i> | N/A | |

If a non-digital signal is selected to drive a digital input, the signal is interpreted to be OFF at or below the minimum of selected source and ON at or above the maximum of the selected source, and it will not change in between those points. Thus analog to digital interpretation has a built in hysteresis defined by minimum and maximum of the selected source, as shown in Figure 6. For example Universal Input signal is interpreted to be ON at or above “Maximum Range” and OFF at or below “Minimum Range”.

Control Constant Data has no unit nor minimum and maximum assigned to it, thus user has to assign appropriate constant values according to intended use.

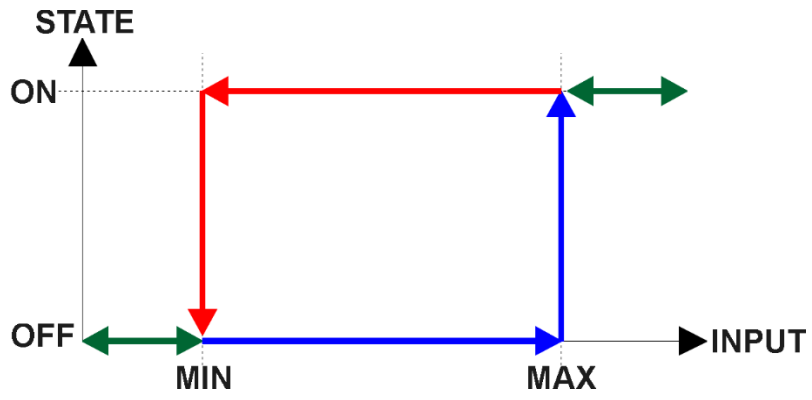

Figure 6 – Analog source to Digital input

2. INSTALLATION INSTRUCTIONS

2.1. Dimensions and Pinout

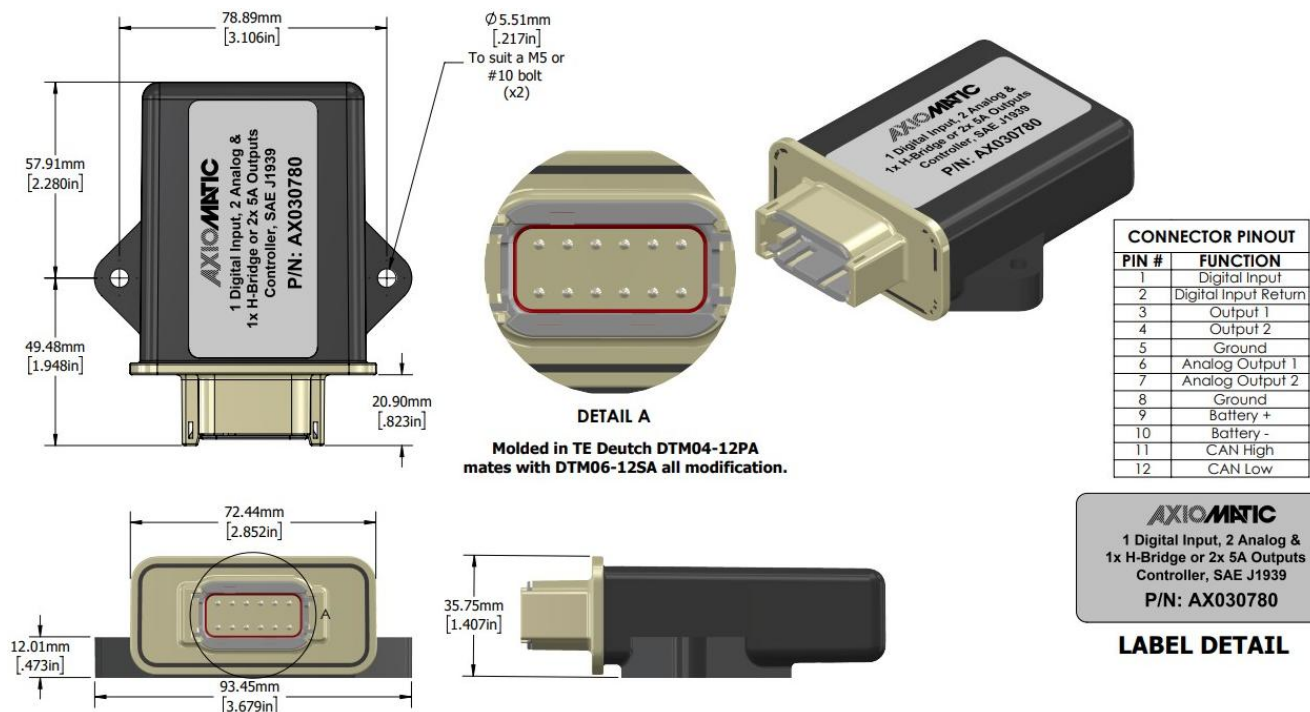

Figure 7 – AX030780 Dimensional Drawing

Table 24 – AX030780 Connector Pinout

| Pin | Function |
|-----|---------------------------------|
| 1 | Digital Input |
| 2 | Digital Input Return |
| 3 | Proportional / Digital Output 1 |
| 4 | Proportional / Digital Output 2 |
| 5 | Ground |
| 6 | Analog Output 1 |
| 7 | Analog Output 2 |
| 8 | Ground |
| 9 | Battery + |
| 10 | Battery - |
| 11 | CAN High |
| 12 | CAN Low |

3. OVERVIEW OF J1939 FEATURES

The software was designed to provide flexibility to the user with respect to messages sent from the ECU by providing:

- Configurable ECU Instance in the NAME (to allow multiple ECUs on the same network)
- Configurable Input Parameters
- Configurable PGN and Data Parameters
- Configurable Diagnostic Messaging Parameters, as required
- Diagnostic Log, maintained in non-volatile memory

3.1. Introduction to Supported Messages

The ECU is compliant with the standard SAE J1939 and supports following PGNs from the standard.

From J1939-21 – Data Link Layer

- | | | |
|--|------------|----------|
| • Request | 59904 | 0x00EA00 |
| • Acknowledgement | 59392 | 0x00E800 |
| • Transport Protocol – Connection Management | 60416 | 0x00EC00 |
| • Transport Protocol – Data Transfer Message | 60160 | 0x00EB00 |
| • Proprietary B | from 65280 | 0x00FF00 |
| | to 65535 | 0x00FFFF |

From J1939-73 – Diagnostics

- | | | |
|--|-------|----------|
| • DM1 – Active Diagnostic Trouble Codes | 65226 | 0x00FECA |
| • DM2 – Previously Active Diagnostic Trouble Codes | 65227 | 0x00FECB |
| • DM3 – Diagnostic Data Clear/Reset for Previously Active DTCs | 65228 | 0x00FECC |
| • DM11 – Diagnostic Data Clear/Reset for Active DTCs | 65235 | 0x00FED3 |

From J1939-81 – Network Management

- | | | |
|--------------------------------|-------|----------|
| • Address Claimed/Cannot Claim | 60928 | 0x00EE00 |
| • Commanded Address | 65240 | 0x00FED8 |

From J1939-71 – Vehicle Application Layer

- | | | |
|----------------------------|-------|----------|
| • Software Identification | 65242 | 0x00FEDA |
| • Software Identification | 65242 | 0x00FEDA |
| • Component Identification | 65259 | 0x00FEED |

None of the application layer PGNs are supported as part of the default configurations, but they can be selected as desired for transmit function blocks.

Setpoints are accessed using standard Memory Access Protocol (MAP) with proprietary addresses. The Axiomatic Electronic Assistant (EA) allows for quick and easy configuration of the unit over CAN network.

3.2. NAME, Address and Software ID

The Interface Module ECU has the following default for the J1939 NAME. The user should refer to the SAE J1939/81 standard for more information on these parameters and their ranges.

| | |
|---------------------------|---|
| Arbitrary Address Capable | Yes |
| Industry Group | 0, Global |
| Vehicle System Instance | 0 |
| Vehicle System | 0, Non-specific system |
| Function | 124, I/O Controller |
| Function Instance | 8, Axiomatic AX030780 |
| ECU Instance | 0, First Instance |
| Manufacture Code | 162, Axiomatic Technologies |
| Identity Number | Variable, uniquely assigned during factory programming for each ECU |

The ECU Instance is a configurable setpoint associated with the NAME. Changing this value will allow multiple ECUs of this type to be distinguishable from one another when they are connected on the same network.

The default value of the “ECU Address” setpoint is 128 (0x80), which is the preferred starting address for self-configurable ECUs as set by the SAE in J1939 tables B3 and B7. The EA will allow the selection of any address between 0 and 253. ***It is user’s responsibility to select an address that complies with the standard.*** The user must also be aware that since the unit is arbitrary address capable, if another ECU with a higher priority NAME contends for the selected address, the 2 Out CAN Controller will continue select the next highest address until it finds one that it can claim. See J1939/81 for more details about address claiming.

ECU Identification Information

| | | | |
|-------------------------------|---------------------------------|--|--------|
| PGN 64965 | ECU Identification Information | | -ECUID |
| Transmission Repetition Rate: | On request | | |
| Data Length: | Variable | | |
| Extended Data Page: | 0 | | |
| Data Page: | 0 | | |
| PDU Format: | 253 | | |
| PDU Specific: | 197 PGN Supporting Information: | | |
| Default Priority: | 6 | | |
| Parameter Group Number: | 64965 (0x00FDC5) | | |
| Start Position | Length | Parameter Name | SPN |
| a | Variable | ECU Part Number, Delimiter (ASCII “*”) | 2901 |
| b | Variable | ECU Serial Number, Delimiter (ASCII “*”) | 2902 |
| c | Variable | ECU Location, Delimiter (ASCII “*”) | 2903 |
| d | Variable | ECU Type, Delimiter (ASCII “*”) | 2904 |
| e | Variable | ECU Manufacturer Name, Delimiter (ASCII “*”) | 4304 |
| (a)*(b)*(c)*(d)*(e)* | | | |

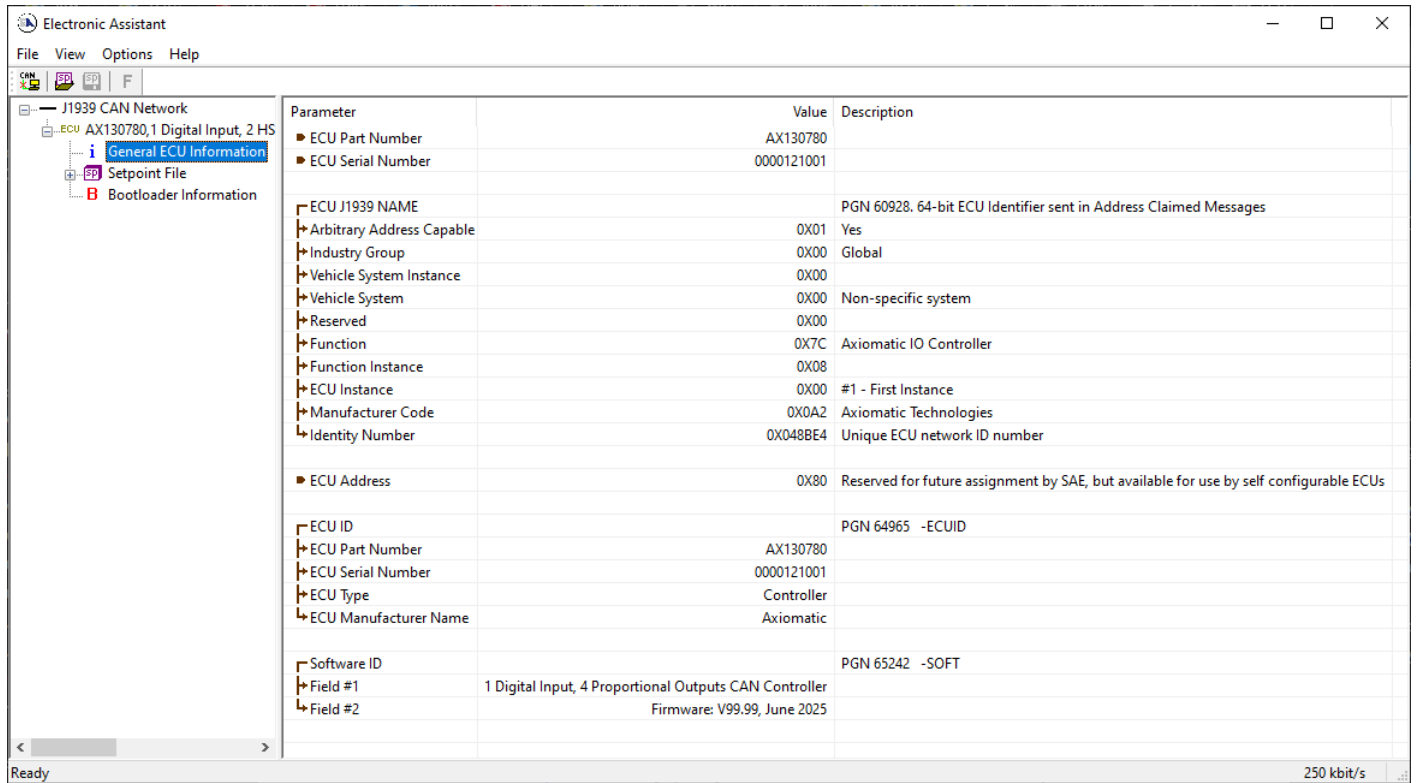

Figure 8 – General ECU Information

Software Identifier

| | | |
|-------------------------------|---------------------------------|---|
| PGN 65242 | Software Identification | - SOFT |
| Transmission Repetition Rate: | On request | |
| Data Length: | Variable | |
| Extended Data Page: | 0 | |
| Data Page: | 0 | |
| PDU Format: | 254 | |
| PDU Specific: | 218 PGN Supporting Information: | |
| Default Priority: | 6 | |
| Parameter Group Number: | 65242 (0xFEDA) | |
| Start Position | Length | Parameter Name |
| 1 | 1 Byte | Number of software identification fields |
| 2-n | Variable | Software identification(s), Delimiter (ASCII “*”) |
| | | SPN |
| | | 965 |
| | | 234 |

For the Interface Module ECU, Byte 1 is set to 5, and the identification fields are as follows.

(Part Number)*(Version)*(Date)*(Owner)*(Description)

The EA shows all this information in “General ECU Information”, as shown below.

Note: The information provided in the Software ID is available for any J1939 service tool which supports the PGN -SOFT.

Component Identification

| | | | |
|-------------------------------|----------|---|-----|
| PGN 65259 | | Component Identification | -CI |
| Transmission Repetition Rate: | | On request | |
| Data Length: | | Variable | |
| Extended Data Page: | | 0 | |
| Data Page: | | 0 | |
| PDU Format: | | 254 | |
| PDU Specific: | | 235 PGN Supporting Information: | |
| Default Priority: | | 6 | |
| Parameter Group Number: | | 65259 (0x00FEEB) | |
| Start Position | Length | Parameter Name | SPN |
| a | 1-5 Byte | Make, Delimiter (ASCII “*”) | 586 |
| b | Variable | Model, Delimiter (ASCII “*”) | 587 |
| c | Variable | Serial Number, Delimiter (ASCII “*”) | 588 |
| d | Variable | Unit Number (Power Unit), Delimiter (ASCII “*”) | 233 |
| (a)*(b)*(c)*(d)*(e)* | | | |

4. ECU SETPOINTS ACCESSED WITH AXIOMATIC ELECTRONIC ASSISTANT

This section describes in detail each setpoint, and their defaults and ranges. The setpoints are divided into setpoint groups as they are shown in EA. For more information on how each setpoints, refer to the relevant section in this user manual.

4.1. Accessing the ECU Using Axiomatic Electronic Assistant

ECU with P/N AX030780 does not need any specific setup for EA. In order to access the high-speed versions, the CAN bus Baud Rate needs to be set accordingly. The CAN Interface Setup can be found from “Options” menu in EA. Please refer to UMAX07050x **Connecting to the J1939 Bus** section for Axiomatic Electronic Assistant CAN Interface Setup instructions.

The screenshot shows the 'CAN Interface Setup' dialog box with the following configuration:

- Hardware Interface Module:** Axiomatic USB-CAN Converter
- Axiomatic USB-CAN Converter:**
 - Use First Available
 - Converter Name & State: USBCAN #5 --> Active
- Axiomatic Ethernet-CAN Converter:**
 - Remote IP Address: 127.0.0.1
 - Remote Port: 4000
 - Port Type: UDP TCP
 - Group: 0 Channel: 1
- ESD CAN-USB Converter:**
 - Logical Network Number: 0
- Communication:**
 - Baud Rate: 250 kbit/s
 - J1939 Standard Baud Rate

Buttons: Cancel, OK

4.2. J1939 Network Parameters

“ECU Instance Number” and “ECU Address” setpoints and their effect are defined in section 3.2.

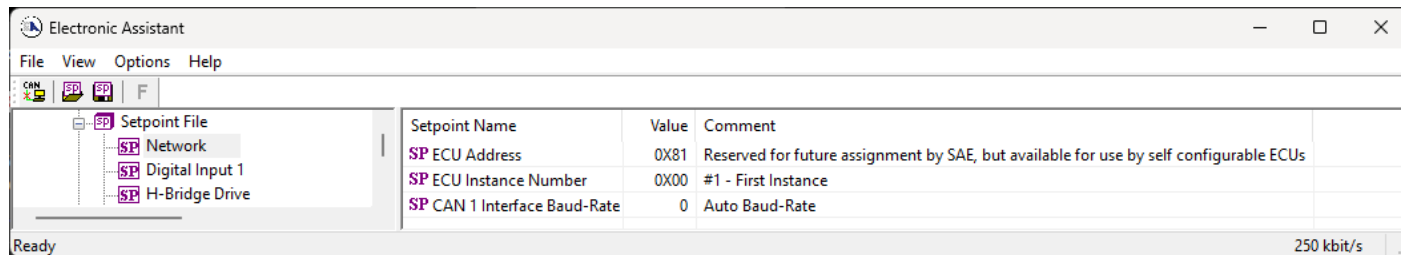

Figure 9 – Screen Capture of J1939 Setpoints

Table 25 – J1939 Network Setpoints

| Name | Range | Default | Notes |
|-------------------------|-------|---------|--|
| ECU Address | 0x80 | 0-253 | Preferred address for a self-configurable ECU |
| ECU Instance | 0-7 | 0x00 | Per J1939-81 |
| CAN Interface Baud-Rate | 0-4 | 0 | Use to configure fixed baud rate or Auto Baud Rate |

If non-default values for the “**ECU Instance Number**” or “**ECU Address**” are used, they will be mirrored during a setpoint file flashing and will only take effect once the entire file has been downloaded to the unit. After the setpoint flashing is complete, the unit will claim the new address and/or re-claim the address with the new NAME. If these setpoints are changing, it is recommended to close and re-open the CAN connection on EA after the file is loaded so that only the new NAME and address are showing in the J1939 CAN Network ECU list.

4.3. Digital Input

The Digital Input are defined in Section 1.1

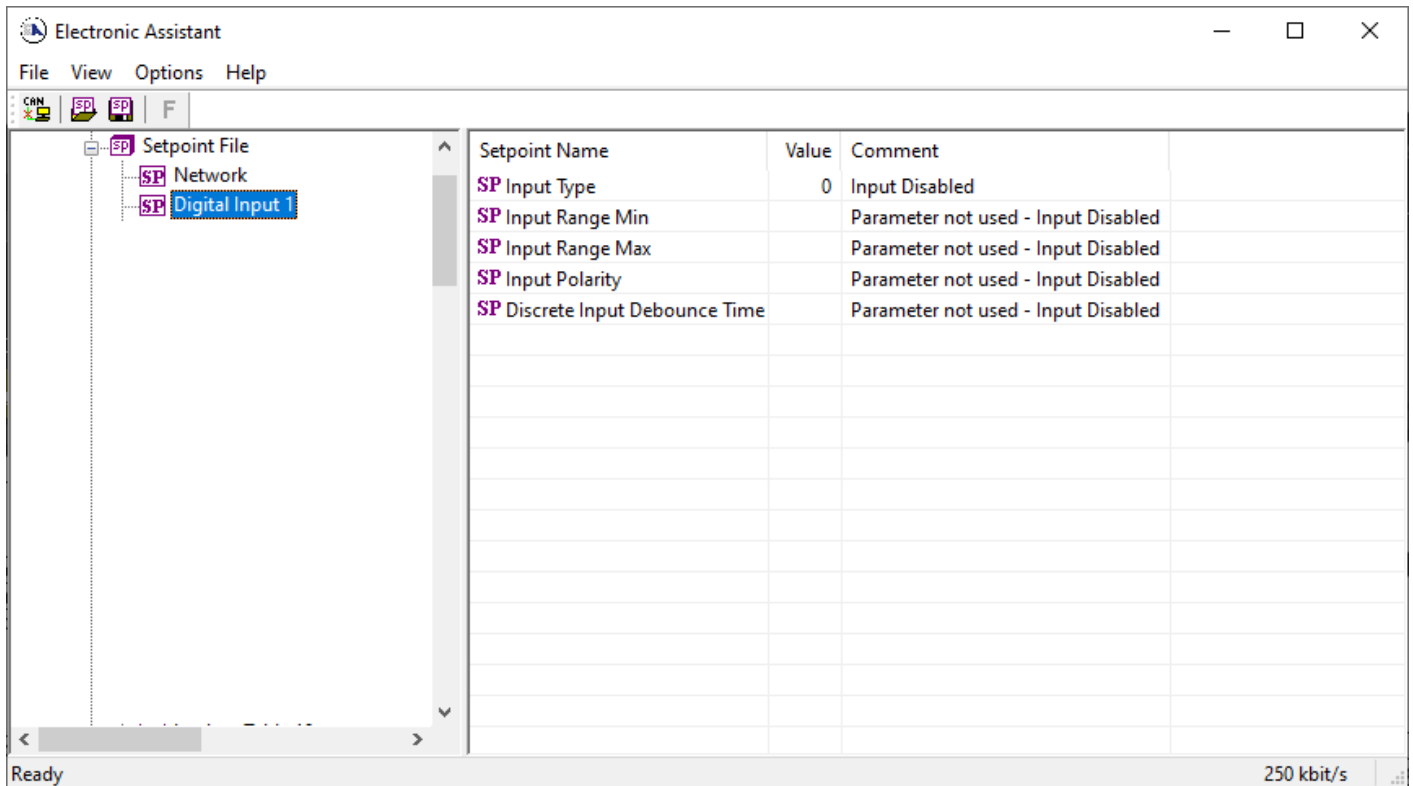

Table 26 – Proportional Output Setpoints

| Name | Range | Default | Notes |
|------------------------------|---------------|----------------|---------|
| Input Type | Drop List | Input Disabled | See 1.1 |
| Input Range Min | 0 | 0 | |
| Input Range Max | 1 | 1 | |
| Input Polarity | Drop List | Active High | |
| Discrete Input Debounce Time | 0 to 65000 ms | 50 | |

4.4. Proportional Output Setpoints

The Proportional Outputs are defined in sections 1.1.

| Setpoint Name | Value | Comment |
|-------------------------------|---------|--|
| SP Output Type | 25 | Proportional Current (0-2500mA) |
| SP Driver Type | 1 | High Side |
| SP Output Data Min | 0 | mA |
| SP Output Data Max | 2500 | mA |
| SP Output Default Value | 0 | mA |
| SP Dither Frequency | 1000 | Hz |
| SP Dither Amplitude | 0 | mA |
| SP Output Ramp Up Time | 0 | ms |
| SP Output Ramp Down Time | 0 | ms |
| SP PWM Output Frequency | | Parameter not used with current Output Type selected |
| SP Digital Response | | Parameter not used with current Output Type selected |
| SP Control Source | 176 | Received CAN Message |
| SP Control Number | 1 | Received CAN Message 1 |
| SP Control Response | 1 | OFF When Below Minimum |
| SP Output Delay Polarity | | Parameter not used with current Output Type selected |
| SP Enable Source | 0 | Control Not Used |
| SP Enable Number | | Parameter not used with current Enable Source selected |
| SP Enable Response | | Parameter not used with current Enable Source selected |
| SP Override Source | 0 | Control Not Used |
| SP Override Number | | Parameter not used with current Enable Source selected |
| SP Override Response | | Parameter not used with current Enable Source selected |
| SP Override Output Value | | Parameter not used with current Enable Source selected |
| SP Fault Detection is Enabled | 0 | False |
| SP Control Fault Response | | Parameter not used - Fault Detection is Disabled |
| SP Output in Fault Mode | | Parameter not used - Fault Detection is Disabled |
| SP PID Gain | 0.11000 | |
| SP PID Ti | 0.00050 | |
| SP PID Td | 0.00000 | |

Ready 250 kbit/s

Figure 10 – Screen Capture of Proportional Output Setpoints

Table 27 – Proportional Output Setpoints

| Name | Range | Default | Notes |
|----------------------------|---------------------------|--------------------------------|---|
| Output Type | Drop List | Proportional current | See Table 4 |
| Driver Type | Drop List | High Side | This setpoint configures the Output Driver to operate in either High-Side or Low-Side mode. |
| Output Data Min | 0 to Limit | 0mA | This setpoint is Hold Current in Digital Hotshot mode |
| Output Data Max | 0 to Limit | 5000mA | This setpoint is Hotshot Current in Digital Hotshot mode |
| Output Default Value | 0 to Limit | 0mA | |
| Dither Frequency | 50 to 500Hz | 250Hz | |
| Dither Amplitude | 0 to 500 mA | 0 | |
| Ramp Up (Min to Max) | 0 to 10 000ms | 1000ms | This setpoint is Hotshot Time in Digital Hotshot mode and Digital Delay Time in Digital ON/OFF mode |
| Ramp Down (Max to Min) | 0 to 10 000ms | 1000ms | This setpoint is Digital Blink Rate in Digital Hotshot and Digital ON/OFF mode |
| PWM Output Frequency | 1Hz to 25 000Hz | 2000Hz | |
| Digital Response | Drop List | Normal On/Off | See Table 5 |
| Control Source | Drop List | Not Used | See Table 23 |
| Control Number | Depends on control source | 1 | See Table 23 |
| Enable Source | Drop List | Control not used | See Table 23 |
| Enable Number | Depends on enable source | 1 | See Table 23 |
| Enable Response | Drop List | Enable When On, Else Shutoff | See Table 2 |
| Override Source | Drop List | Control not used | See Table 23 |
| Override Number | Depends on enable source | 1 | See Table 23 |
| Override Response | Drop List | Override When On, Else Shutoff | See Table 2 |
| Override Output Value | 0-2000 | 0 | |
| Fault Detection is Enabled | Drop List | 0, False | |
| Control Fault Response | Drop List | 1, Apply Fault Value | See Table 6 |
| Override Output Value | 0-2000 | 0 | |
| PID Gain | 0-10000 | 0.7 | |
| PID Ti | 0-10000 | 0.0010 | |
| PID Td | 0-10000 | 0.00001 | |

4.5. H-Bridge

The H-Bridge Outputs are defined in sections 1.3

| Setpoint Name | Value | Comment |
|------------------------------|-------|---|
| SP H-Bridge Enabled | 0 | False |
| SP Output At Minimum Command | | Parameter not used - Function Block is Disabled |
| SP Output At Maximum Command | | Parameter not used - Function Block is Disabled |
| SP Ramp Down Time | | Parameter not used - Function Block is Disabled |
| SP Ramp Up Time | | Parameter not used - Function Block is Disabled |
| SP Control Source | | Parameter not used - Function Block is Disabled |
| SP Control Number | | Parameter not used - Function Block is Disabled |
| SP Control Response | | Parameter not used - Function Block is Disabled |
| SP Directon Source | | Parameter not used - Function Block is Disabled |
| SP Direction Number | | Parameter not used - Function Block is Disabled |
| SP Enable Source | | Parameter not used - Function Block is Disabled |
| SP Enable Number | | Parameter not used - Function Block is Disabled |
| SP Enable Response | | Parameter not used - Function Block is Disabled |
| SP Override Source | | Parameter not used - Function Block is Disabled |
| SP Override Number | | Parameter not used - Function Block is Disabled |
| SP Override Response | | Parameter not used - Function Block is Disabled |
| SP Override Output Value | | Parameter not used - Function Block is Disabled |

Table 28 – H-Bridge Output Setpoints

| Name | Range | Default | Notes |
|-------------------------|---------------------------|--------------------------------|--------------|
| H-Bridge Enabled | Drop List | False | |
| Output Data Min Command | -5000mA to Max Limit | 0mA | |
| Output Data Max Command | Min Limit to 5000 | 2500mA | |
| Ramp Down (Max to Min) | 0 to 10 000ms | 1000ms | |
| Ramp Up (Min to Max) | 0 to 10 000ms | 1000ms | |
| Control Source | Drop List | Not Used | See Table 23 |
| Control Number | Depends on control source | 1 | See Table 23 |
| Control Response | Drop List | Single Out Profile | |
| Enable Source | Drop List | Control not used | See Table 23 |
| Enable Number | Depends on enable source | 1 | See Table 23 |
| Enable Response | Drop List | Enable When On, Else Shutoff | See Table 2 |
| Override Source | Drop List | Control not used | See Table 23 |
| Override Number | Depends on enable source | 1 | See Table 23 |
| Override Response | Drop List | Override When On, Else Shutoff | See Table 2 |
| Override Output Value | ±5000mA | 0 | |

4.6. Analog Output Drive

The Analog Outputs are defined in sections 0

| Setpoint Name | Value | Comment |
|-------------------------------|-------|---|
| SP Output Type | 10 | Analog Voltage |
| SP Default Output Value | 0.00 | |
| SP Output At Minimum Command | 0.00 | |
| SP Output At Maximum Command | 5.00 | |
| SP Ramp Up (Min to Max) | 1000 | ms |
| SP Ramp Down (Max to Min) | 1000 | ms |
| SP Control Source | 0 | Control Not Used |
| SP Control Number | | Parameter not used with current Control Source selected |
| SP Control Response | | Parameter not used with current Control Source selected |
| SP Enable Source | | Parameter not used with current Control Source selected |
| SP Enable Number | | Parameter not used with current Control Source selected |
| SP Enable Response | | Parameter not used with current Control Source selected |
| SP Override Source | | Parameter not used with current Control Source selected |
| SP Override Number | | Parameter not used with current Control Source selected |
| SP Override Response | | Parameter not used with current Control Source selected |
| SP Output at Override Command | | Parameter not used with current Control Source selected |
| SP Fault Response | | Parameter not used with current Control Source selected |
| SP Output at Fault Command | | Parameter not used with current Control Source selected |

Ready 250 kbit/s

| Name | Range | Default | Notes |
|----------------------------|-----------|--------------------------------|--------------------------|
| Output Type | Drop List | 1, Analog Voltage | Refer to Section Table 8 |
| Output At Minimum Command | -10...10 | 0 | Refer to Section 0 |
| Output At Maximum Command | -10...10 | 5 | Refer to Section 0 |
| Ramp Up (Min to Max) | 0...10000 | 1000 | Refer to Section 0 |
| Ramp Down (Max to Min) | 0...10000 | 1000 | Refer to Section 0 |
| Control Source | Drop List | 0, Control Not Used | Refer to 1.16 |
| Control Number | | 0 | Refer to 1.16 |
| Control Response | Drop List | 0, Single Output Profile | Refer to Section 1.4.3 |
| Enable Source | Drop List | 0, Control Not Used | Refer to 1.16 |
| Enable Number | | 0 | Refer to 1.16 |
| Enable Response | Drop List | 0, Enable When on Else Shutoff | Refer to Section 1.4.3 |
| Override Source | Drop List | 0, Control Not Used | Refer to 1.16 |
| Override Number | | 0 | Refer to 1.16 |
| Override Response | Drop List | 0, Override when ON | Refer to Section 1.4.3 |
| Output at Override Command | 0-50000 | 0 | Refer to Section 1.4.3 |
| Fault Response | Drop List | 0, Output Shutdown | Refer to Section 1.4.3 |
| Output at Fault Command | 0-50000 | 0 | Refer to Section 1.4.3 |

4.7. Constant Data List

The Constant Data List Function Block is provided to allow the user to select values as desired for various logic block functions.

The first two constants are fixed values of 0 (False) and 1 (True) for use in binary logic. The remaining 13 constants are fully user programmable to any value between +/- 1 000 000. The default values (shown in Figure 11) are arbitrary and should be configured by the user as appropriate for their application.

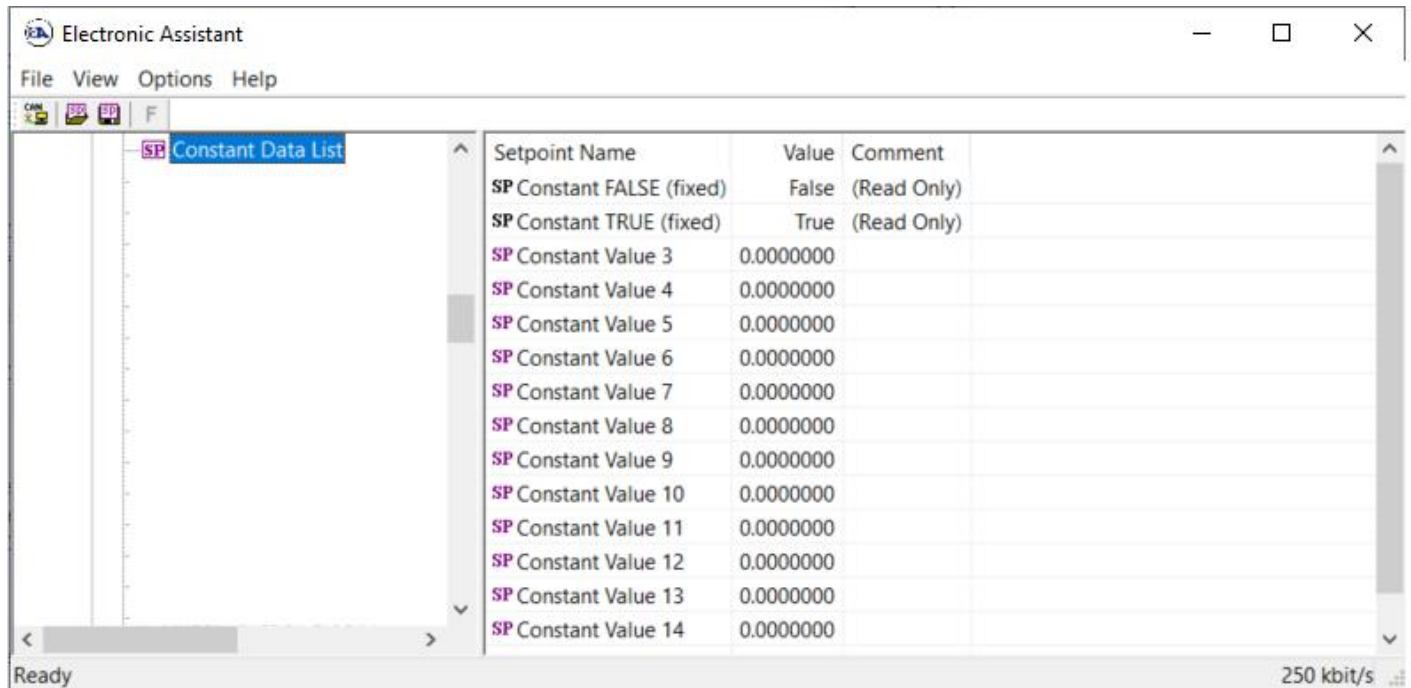

The screenshot shows the 'Electronic Assistant' software window. The title bar includes the application name and standard window controls. The menu bar contains 'File', 'View', 'Options', and 'Help'. Below the menu bar is a toolbar with icons for 'CAN', 'SP', and 'F'. The main workspace displays a 'Constant Data List' table with the following data:

| Setpoint Name | Value | Comment |
|---------------------------|-----------|-------------|
| SP Constant FALSE (fixed) | False | (Read Only) |
| SP Constant TRUE (fixed) | True | (Read Only) |
| SP Constant Value 3 | 0.0000000 | |
| SP Constant Value 4 | 0.0000000 | |
| SP Constant Value 5 | 0.0000000 | |
| SP Constant Value 6 | 0.0000000 | |
| SP Constant Value 7 | 0.0000000 | |
| SP Constant Value 8 | 0.0000000 | |
| SP Constant Value 9 | 0.0000000 | |
| SP Constant Value 10 | 0.0000000 | |
| SP Constant Value 11 | 0.0000000 | |
| SP Constant Value 12 | 0.0000000 | |
| SP Constant Value 13 | 0.0000000 | |
| SP Constant Value 14 | 0.0000000 | |

The status bar at the bottom of the window shows 'Ready' on the left and '250 kbit/s' on the right.

Figure 11 – Screen Capture of Constant Data List Setpoints

4.8. Lookup Table

The Lookup Table Function Block is defined in Section 1.10 Please refer there for detailed information about how all these setpoints are used. “**X-Axis Source**” is set to ‘*Control Not Used*’ by default. To enable a Lookup Table select appropriate “**X-Axis Source**”.

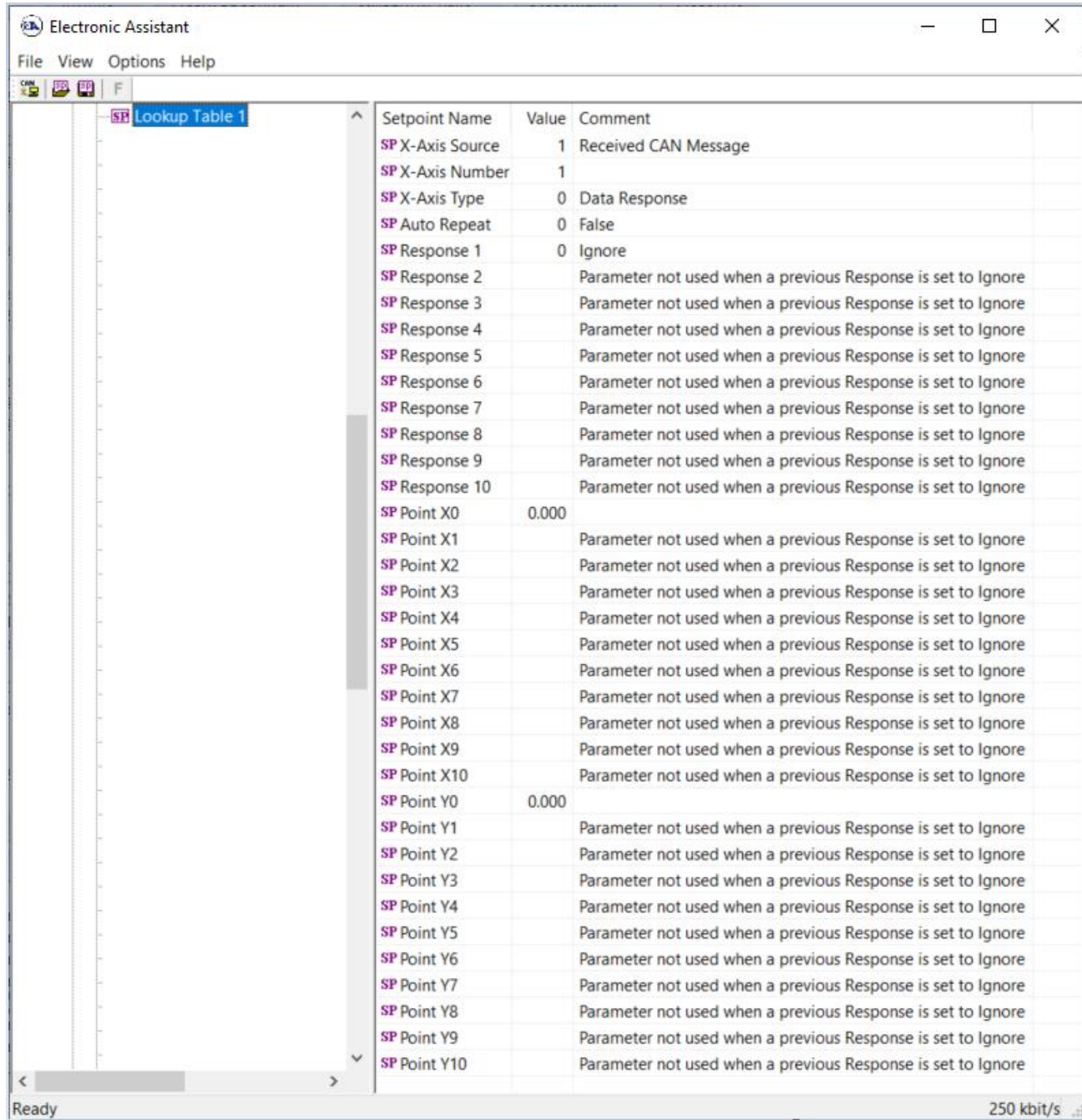

Figure 12 – Screen Capture of Lookup table Setpoints

Table 29 – Lookup Table Setpoints

| Name | Range | Default | Notes |
|---------------------|--|--------------------------------|------------------|
| X-Axis Source | Drop List | Control Not Used | See Table 23 |
| X-Axis Number | Depends on control source | 1 | See Table 23 |
| X-Axis Type | Drop List | Data Response | See Table 19 |
| Table Auto-Cycle | Drop List | 0 | |
| Point 1 - Response | Drop List | Ramp To | See Table 20 |
| Point 2 - Response | Drop List | Ramp To | See Table 20 |
| Point 3 - Response | Drop List | Ramp To | See Table 20 |
| Point 4 - Response | Drop List | Ramp To | See Table 20 |
| Point 5 - Response | Drop List | Ramp To | See Table 20 |
| Point 6 - Response | Drop List | Ramp To | See Table 20 |
| Point 7 - Response | Drop List | Ramp To | See Table 20 |
| Point 8 - Response | Drop List | Ramp To | See Table 20 |
| Point 9 - Response | Drop List | Ramp To | See Table 20 |
| Point 10 - Response | Drop List | Ramp To | See Table 20 |
| Point 0 - X Value | From X-Axis source minimum | X-Axis source minimum 0.000 | See Section 1.10 |
| Point 1 - X Value | From X-Axis source minimum to Point 1 - X Value | 0.500 | See Section 1.10 |
| Point 2 - X Value | From Point 0 - X Value to Point 2 - X Value | 1.000 | See Section 1.10 |
| Point 3 - X Value | From Point 1 - X Value to Point 3 - X Value | 1.500 | See Section 1.10 |
| Point 4 - X Value | From Point 2 - X Value to Point 4 - X Value | 2.000 | See Section 1.10 |
| Point 5 - X Value | From Point 3 - X Value to Point 5 - X Value source | 2.500 | See Section 1.10 |
| Point 6 - X Value | From Point 4 - X Value to Point 6 - X Value | 3.000 | See Section 1.10 |
| Point 7 - X Value | From Point 5 - X Value to Point 7 - X Value | 3.500 | See Section 1.10 |
| Point 8 - X Value | From Point 6 - X Value to Point 8 - X Value | 4.000 | See Section 1.10 |
| Point 9 - X Value | From Point 7 - X Value to Point 9 - X Value | 4.500 | See Section 1.10 |
| Point 10 - X Value | From Point 8 - X Value to Point 10 - X Value | 5.000 | See Section 1.10 |
| Point 0 - Y Value | -10^6 to 10^6 | 0.000 | |
| Point 1 - Y Value | -10^6 to 10^6 | 10.000 | |
| Point 2 - Y Value | -10^6 to 10^6 | 20.000 | |
| Point 3 - Y Value | -10^6 to 10^6 | 30.000 | |
| Point 4 - Y Value | -10^6 to 10^6 | 40.000 | |
| Point 5 - Y Value | -10^6 to 10^6 | 50.000 | |
| Point 6 - Y Value | -10^6 to 10^6 | 60.000 | |
| Point 7 - Y Value | -10^6 to 10^6 | 70.000 | |
| Point 8 - Y Value | -10^6 to 10^6 | 80.000 | |
| Point 9 - Y Value | -10^6 to 10^6 | 90.000 | |
| Point 10 - Y Value | -10^6 to 10^6 | 100.000 | |

4.9. PID Control

The PID Control Function Block is defined in Section 1.5. Please refer there for detailed information about how all these setpoints are used.

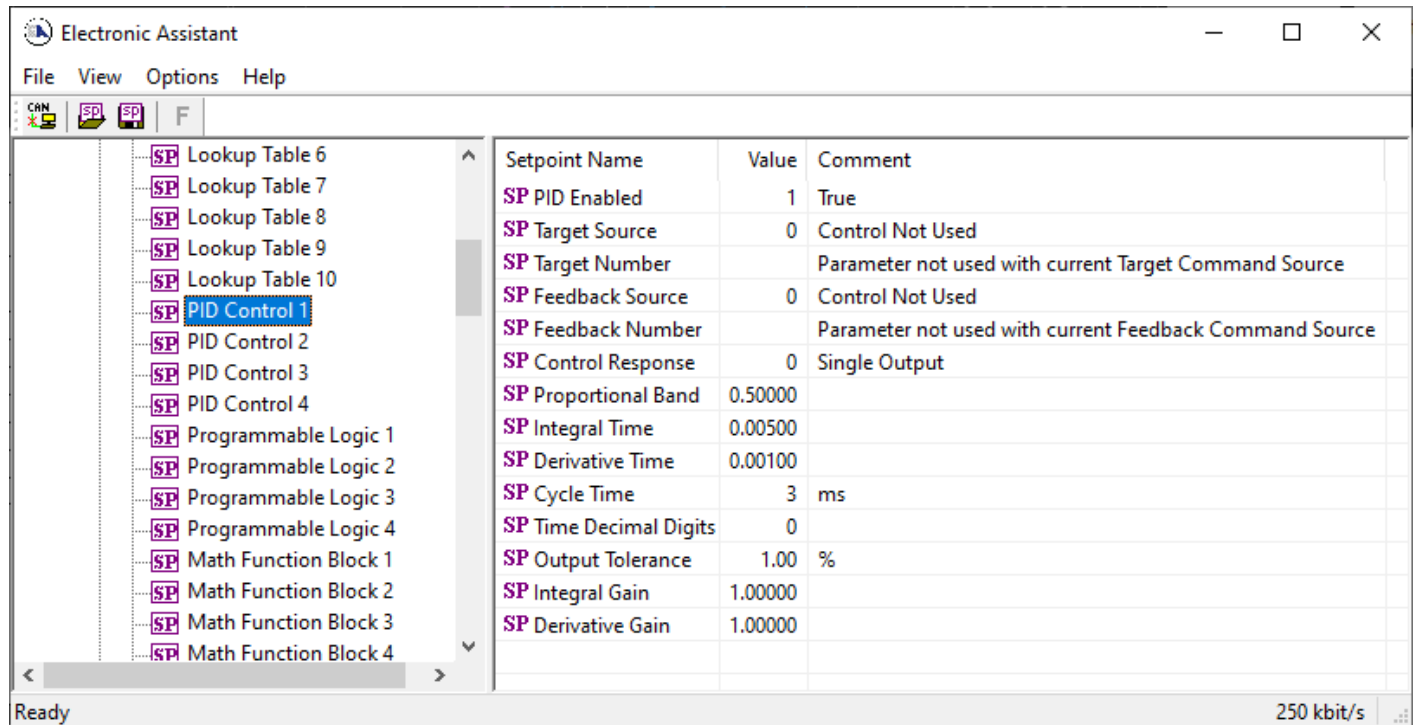

Figure 13 – Screen Capture of PID Blok setpoints

Table 30 – PID Function Block Setpoints

| Name | Range | Default | Notes |
|---------------------|---------------------------|------------------|---------|
| PID Enabled | Drop List | False | See 1.5 |
| Target Source | Drop List | No Source | See 1.5 |
| Target Number | Depends on Control Source | 1 | See 1.5 |
| Feedback Source | Drop List | No Source | See 1.5 |
| Feedback Number | Depends on Control Source | 1 | See 1.5 |
| Control Response | Drop list | 0, Single Output | See 1.5 |
| Proportional Band | 0 – 10000 | 0.5 | See 1.5 |
| Integral Gain | 0 – 10000 | 0.005 | See 1.5 |
| Derivative Time | 0 - 10000 | 0.001 | See 1.5 |
| Cycle Time | 0 – 1000 | 3 ms | See 1.5 |
| Time Decimal Digits | 0 – 3 | 0 | See 1.5 |
| Output Tolerance | 0 – 100 | 1% | See 1.5 |
| Integral Gain | 0 – 10 | 1 | See 1.5 |
| Derivative Gain | 0 – 10 | 1 | See 1.5 |

4.10. Programmable Logic

The Programmable Logic function block is defined in Section 1.11. Please refer there for detailed information about how all these setpoints are used. “**Programmable Logic Enabled**” is ‘*False*’ by default. To enable Logic set “**Programmable Logic Enabled**” to ‘*True*’ and select appropriate “**Argument Source**”.

| Setpoint Name | Value | Comment |
|--|-------|---|
| SP Logic Enabled | 1 | True |
| SP Table Number 1 | 1 | Lookup Table 1 |
| SP Logical Operator 1 | 0 | Default Table |
| SP Table 1 - Condition 1 Argument 1 Source | | Parameter not used with current Logical Operator selected |
| SP Table 1 - Condition 1 Argument 1 Number | | Parameter not used with current Logical Operator selected |
| SP Table 1 - Condition 1 Argument 2 Source | | Parameter not used with current Logical Operator selected |
| SP Table 1 - Condition 1 Argument 2 Number | | Parameter not used with current Logical Operator selected |
| SP Table 1 - Condition 1 Operator | | Parameter not used with current Logical Operator selected |
| SP Table 1 - Condition 2 Argument 1 Source | | Parameter not used with current Logical Operator selected |
| SP Table 1 - Condition 2 Argument 1 Number | | Parameter not used with current Logical Operator selected |
| SP Table 1 - Condition 2 Argument 2 Source | | Parameter not used with current Logical Operator selected |
| SP Table 1 - Condition 2 Argument 2 Number | | Parameter not used with current Logical Operator selected |
| SP Table 1 - Condition 2 Operator | | Parameter not used with current Logical Operator selected |
| SP Table 1 - Condition 3 Argument 1 Source | | Parameter not used with current Logical Operator selected |
| SP Table 1 - Condition 3 Argument 1 Number | | Parameter not used with current Logical Operator selected |
| SP Table 1 - Condition 3 Argument 2 Source | | Parameter not used with current Logical Operator selected |
| SP Table 1 - Condition 3 Argument 2 Number | | Parameter not used with current Logical Operator selected |
| SP Table 1 - Condition 3 Operator | | Parameter not used with current Logical Operator selected |
| SP Table Number 2 | 1 | Lookup Table 1 |
| SP Logical Operator 2 | 0 | Default Table |
| SP Table 2 - Condition 1 Argument 1 Source | | Parameter not used with current Logical Operator selected |
| SP Table 2 - Condition 1 Argument 1 Number | | Parameter not used with current Logical Operator selected |
| SP Table 2 - Condition 1 Argument 2 Source | | Parameter not used with current Logical Operator selected |
| SP Table 2 - Condition 1 Argument 2 Number | | Parameter not used with current Logical Operator selected |
| SP Table 2 - Condition 1 Operator | | Parameter not used with current Logical Operator selected |
| SP Table 2 - Condition 2 Argument 1 Source | | Parameter not used with current Logical Operator selected |
| SP Table 2 - Condition 2 Argument 1 Number | | Parameter not used with current Logical Operator selected |
| SP Table 2 - Condition 2 Argument 2 Source | | Parameter not used with current Logical Operator selected |
| SP Table 2 - Condition 2 Argument 2 Number | | Parameter not used with current Logical Operator selected |
| SP Table 2 - Condition 2 Operator | | Parameter not used with current Logical Operator selected |
| SP Table 2 - Condition 3 Argument 1 Source | | Parameter not used with current Logical Operator selected |

Figure 14 – Screen Capture of Programmable Logic Setpoints

Setpoint ranges and default values for Programmable Logic Blocs are listed in Table 31. Only “**Table1**” setpoint are listed, because other “**TableX**” setpoints are similar, except for the default value of the “**Lookup Table Block Number**” setpoint, which is X for “**TableX**”.

Table 31 – Programmable Logic Setpoints

| Name | Range | Default | Notes |
|--|---------------------------|------------------|--------------|
| Programmable Logic Enabled | Drop List | False | |
| Table1 - Lookup Table Block Number | 1 to 8 | Look up Table 1 | |
| Table1 - Conditions Logical Operation | Drop List | Default Table | See Table 22 |
| Table1 - Condition1, Argument 1 Source | Drop List | Control Not Used | See Table 23 |
| Table1 - Condition1, Argument 1 Number | Depends on control source | 1 | See Table 23 |
| Table1 - Condition1, Operator | Drop List | =, Equal | See Table 21 |
| Table1 - Condition1, Argument 2 Source | Drop List | Control Not Used | See Table 23 |
| Table1 - Condition1, Argument 2 Number | Depends on control source | 1 | See Table 23 |
| Table1 - Condition2, Argument 1 Source | Drop List | Control Not Used | See Table 23 |
| Table1 - Condition2, Argument 1 Number | Depends on control source | 1 | See Table 23 |
| Table1 - Condition2, Operator | Drop List | =, Equal | See Table 21 |
| Table1 - Condition2, Argument 2 Source | Drop List | Control Not Used | See Table 23 |
| Table1 - Condition2, Argument 2 Number | Depends on control source | 1 | See Table 23 |
| Table1 - Condition3, Argument 1 Source | Drop List | Control Not Used | See Table 23 |
| Table1 - Condition3, Argument 1 Number | Depends on control source | 1 | See Table 23 |
| Table1 - Condition3, Operator | Drop List | =, Equal | See Table 21 |
| Table1 - Condition3, Argument 2 Source | Drop List | Control Not Used | See Table 23 |
| Table1 - Condition3, Argument 2 Number | Depends on control source | 1 | See Table 23 |

4.11. Math Function Block

The Math Function Block is defined in Section 1.7. Please refer there for detailed information about how all these setpoints are used. “**Math Function Enabled**” is ‘False’ by default. To enable a Math function Block, set “**Math Function Enabled**” to ‘True’ and select appropriate “**Input Source**”.

| Setpoint Name | Value | Comment |
|------------------------------|--------|---|
| SP Math Enabled | 1 | True |
| SP Math Output Minimum Range | 0.00 | |
| SP Math Output Maximum Range | 100.00 | |
| SP Input 1 Source | 0 | Control Not Used |
| SP Input 1 Number | | Parameter not used with current Control Source selected |
| SP Input 1 Minimum | | Parameter not used with current Control Source selected |
| SP Input 1 Maximum | | Parameter not used with current Control Source selected |
| SP Input 1 Gain | | Parameter not used with current Control Source selected |
| SP Input 2 Source | 0 | Control Not Used |
| SP Input 2 Number | | Parameter not used with current Control Source selected |
| SP Input 2 Minimum | | Parameter not used with current Control Source selected |
| SP Input 2 Maximum | | Parameter not used with current Control Source selected |
| SP Input 2 Gain | | Parameter not used with current Control Source selected |
| SP Input 3 Source | 0 | Control Not Used |
| SP Input 3 Number | | Parameter not used with current Control Source selected |
| SP Input 3 Minimum | | Parameter not used with current Control Source selected |
| SP Input 3 Maximum | | Parameter not used with current Control Source selected |
| SP Input 3 Gain | | Parameter not used with current Control Source selected |
| SP Input 4 Source | 0 | Control Not Used |
| SP Input 4 Number | | Parameter not used with current Control Source selected |
| SP Input 4 Minimum | | Parameter not used with current Control Source selected |
| SP Input 4 Maximum | | Parameter not used with current Control Source selected |
| SP Input 4 Gain | | Parameter not used with current Control Source selected |
| SP Math Function 1 | | Parameter not used with current Control Source selected |
| SP Math Function 2 | | Parameter not used with current Control Source selected |
| SP Math Function 3 | | Parameter not used with current Control Source selected |

Figure 15 – Screen Capture of Math Function Block Setpoints

Table 32 – Math Function Setpoints

| Name | Range | Default | Notes |
|----------------------------|---------------------------|-----------------------------|--------------|
| Math Function Enabled | Drop List | False | |
| Function 1 Input A Source | Drop List | Control not used | See Table 23 |
| Function 1 Input A Number | Depends on control source | 1 | See Table 23 |
| Function 1 Input A Minimum | -10^6 to 10^6 | 0.0 | |
| Function 1 Input A Maximum | -10^6 to 10^6 | 100.0 | |
| Function 1 Input A Scaler | -1.00 to 1.00 | 1.00 | |
| Function 1 Input B Source | Drop List | Control not used | See Table 23 |
| Function 1 Input B Number | Depends on control source | 1 | See Table 23 |
| Function 1 Input B Minimum | -10^6 to 10^6 | 0.0 | |
| Function 1 Input B Maximum | -10^6 to 10^6 | 100.0 | |
| Function 1 Input B Scaler | -1.00 to 1.00 | 1.00 | |
| Math Function 1 Operation | Drop List | =, True when InA Equals InB | See Table 15 |
| Function 2 Input B Source | Drop List | Control not used | See Table 23 |
| Function 2 Input B Number | Depends on control source | 1 | See Table 23 |
| Function 2 Input B Minimum | -10^6 to 10^6 | 0.0 | |
| Function 2 Input B Maximum | -10^6 to 10^6 | 100.0 | |
| Function 2 Input B Scaler | -1.00 to 1.00 | 1.00 | |
| Math Function 3 Operation | Drop List | =, True when InA Equals InB | See Table 15 |
| Function 3 Input B Source | Drop List | Control not used | See Table 23 |
| Function 3 Input B Number | Depends on control source | 1 | See Table 23 |
| Function 3 Input B Minimum | -10^6 to 10^6 | 0.0 | |
| Function 3 Input B Maximum | -10^6 to 10^6 | 100.0 | |
| Function 3 Input B Scaler | -1.00 to 1.00 | 1.00 | |
| Math Function 3 Operation | Drop List | =, True when InA Equals InB | See Table 15 |
| Function 4 Input B Source | Drop List | Control not used | See Table 23 |
| Function 4 Input B Number | Depends on control source | 1 | See Table 23 |
| Function 4 Input B Minimum | -10^6 to 10^6 | 0.0 | |
| Function 4 Input B Maximum | -10^6 to 10^6 | 100.0 | |
| Function 4 Input B Scaler | -1.00 to 1.00 | 1.00 | |
| Math Function 4 Operation | Drop List | =, True when InA Equals InB | See Table 15 |
| Math Output Minimum Range | -10^6 to 10^6 | 0.0 | |
| Math Output Maximum Range | -10^6 to 10^6 | 100.0 | |

4.12. Conditional Logic Block Setpoints

The Conditional Block setpoints are defined in Section 1.8. Refer to that section for detailed information on how these setpoints are used. The screen capture in Figure 16 displays the available setpoints for each of the Conditional Blocks. The table below the screen capture highlights the allowable ranges for each setpoint.

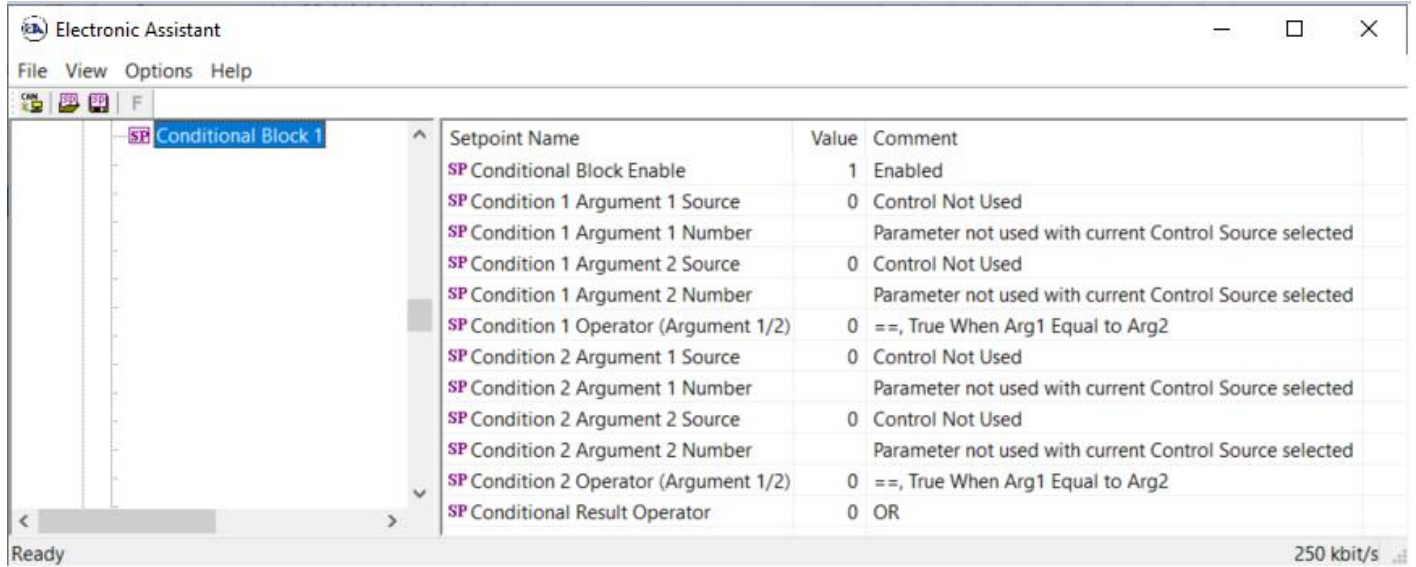

Figure 16 – Screen Capture of Conditional Block Setpoints

Table 33 – Default Conditional Block Setpoints

| Name | Range | Default | Notes |
|-------------------------------------|----------------------------|---------------|-------------------|
| Conditional Function Enabled | Drop List | Disabled | |
| Condition 1 Argument 1 Source | Drop List | Digital Input | Refer to Table 23 |
| Condition 1 Argument 1 Number | Depends on Source Selected | 0 | Refer to Table 23 |
| Condition 1 Argument 2 Source | Drop List | Digital Input | Refer to Table 23 |
| Condition 1 Argument 2 Number | Depends on Source Selected | 0 | Refer to Table 23 |
| Condition 1 Operator (Argument 1/2) | Drop List | 0 | Refer to Table 16 |
| Condition 2 Argument 1 Source | Drop List | Digital Input | Refer to Table 23 |
| Condition 2 Argument 1 Number | Depends on Source Selected | 0 | Refer to Table 23 |
| Condition 2 Argument 2 Source | Drop List | Digital Input | Refer to Table 23 |
| Condition 2 Argument 2 Number | Depends on Source Selected | 0 | Refer to Table 23 |
| Condition 2 Operator (Argument 1/2) | Drop List | 0 | Refer to Table 16 |
| Conditional Result Operator | Drop List | OR | Refer to Table 17 |

4.13. Set-Reset Latch Block

The Set-Reset Latch Block setpoints are defined in Section 1.9. Refer to that section for detailed information on how these setpoints are used. The screen capture in Figure 17 displays the available setpoints for each of the Set-Reset Latch Blocks. The table below the screen capture highlights the allowable ranges for each setpoint.

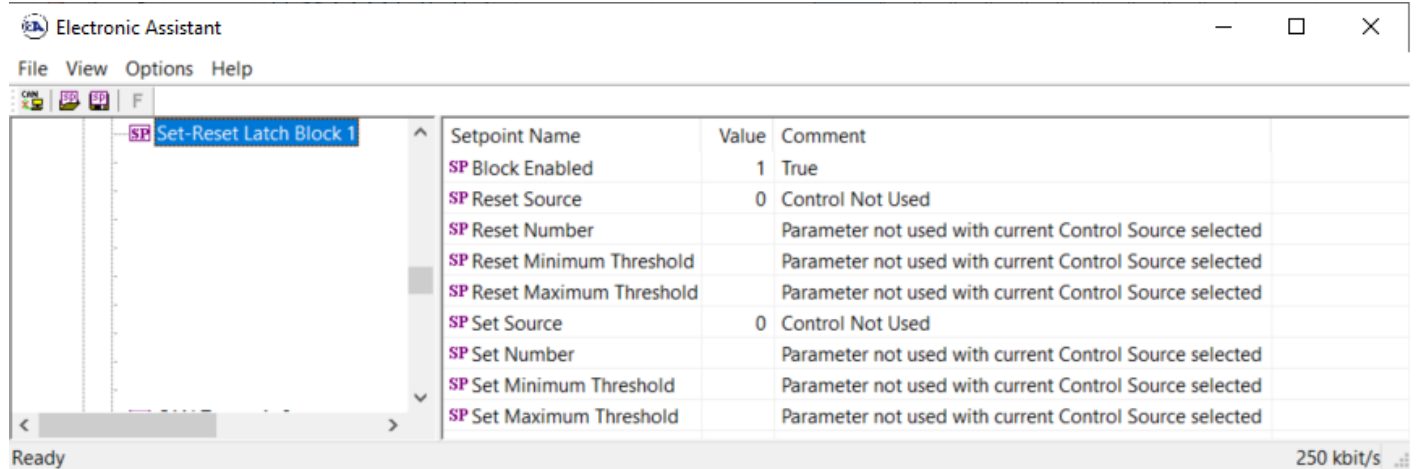

Figure 17 – Screen Capture of Set-Reset Latch Block Setpoints

Table 34 – Default Set-Reset Latch Block Setpoints

| Name | Range | Default | Notes |
|-------------------------|----------------------------|------------------|----------------------|
| Block Enabled | Drop List | False | |
| Reset Source | Drop List | Control Not Used | Refer to Table 23 |
| Reset Number | Depends on Source Selected | 1 | Refer to Table 23 |
| Reset Minimum Threshold | Drop List | 0% | Refer to Section 1.9 |
| Reset Maximum Threshold | Depends on Source Selected | 100% | Refer to Section 1.9 |
| Set Source | Drop List | Control Not Used | Refer to Table 23 |
| Set Number | Drop List | 1 | Refer to Table 23 |
| Set Minimum Threshold | Depends on Source Selected | 0% | Refer to Section 1.9 |
| Set Maximum Threshold | Drop List | 100% | Refer to Section 1.9 |

4.14. CAN Transmit Setpoints

CAN Transmit Message Function Block is presented in section 1.14. Please refer there for detailed information how these setpoints are used. **“Transmit Repetition Rate”** is 0ms by default, thus no message will be sent.

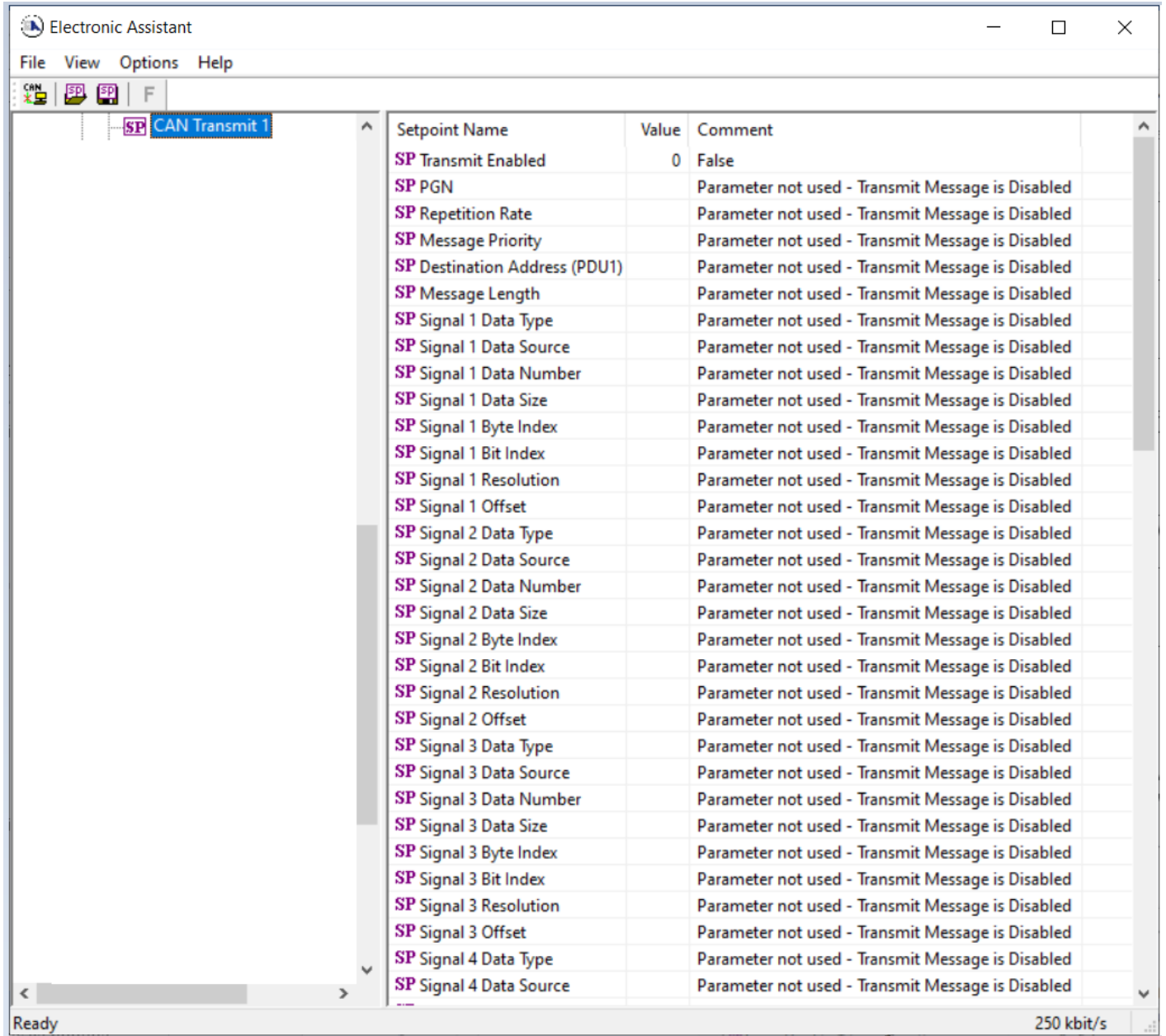

Figure 18 – Screen Capture of CAN Transmit Message Setpoints

Table 35 – CAN Transmit Message Setpoints

| Name | Range | Default | Notes |
|---------------------------------------|---------------------|--------------------|------------------------|
| CAN Interface | Drop List | CAN Interface #1 | |
| Transmit Enabled | Drop List | 0, False | |
| Transmit PGN | 0xff00 ... 0xffff | Different for each | See section 1.14.1 |
| Transmit Repetition Rate | 0 ... 65000 ms | 0ms | 0ms disables transmit |
| Transmit Message Priority | 0...7 | 6 | Proprietary B Priority |
| Destination Address | 0...255 | 255 | Not used by default |
| Signal X Control Source | Drop List | Different for each | See Table 23 |
| Signal X Control Number | Drop List | Different for each | See 1.14.2 |
| Signal X Transmit Data Size | Drop List | 2 bytes | |
| Signal X Transmit Data Index in Array | 0-7 | 0 | |
| Signal X Transmit Bit Index In Byte | 0-7 | 0 | |
| Signal X Transmit Data Resolution | -100000.0 to 100000 | 1/bits | |
| Signal X Transmit Data Offset | -10000 to 10000 | 0.0 | |
| Signal X Transmit Data Minimum | -100000.0 to 100000 | 0.0 | |
| Signal X Transmit Data Maximum | -100000.0 to 100000 | 65535.0 | |

4.15. CAN Receive Setpoints

The CAN Receive Block is defined in section 1.14. Please refer there for detailed information about how these setpoints are used. “**Receive Message Timeout**” is set to 0ms by default. To enable Receive message set “**Receive Message Timeout**” that differs from zero.

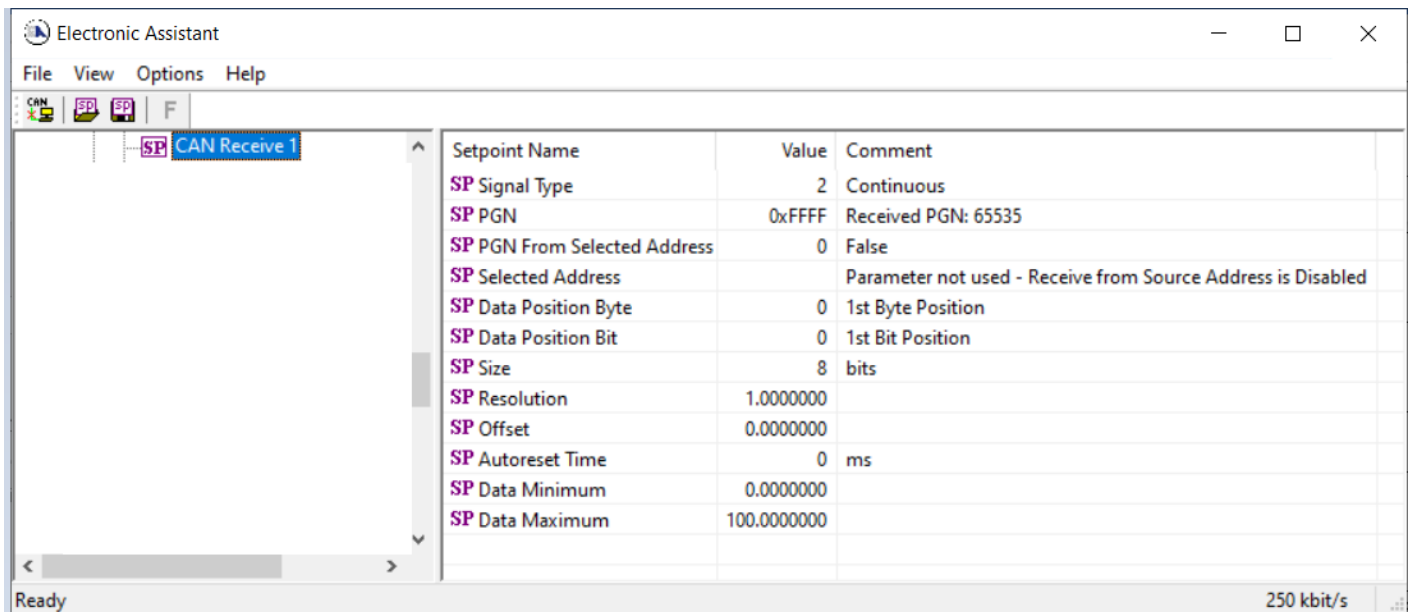

Figure 19 – Screen Capture of CAN Receive Message Setpoints

Table 36 – CAN Receive Setpoints

| Name | Range | Default | Notes |
|--------------------------------------|---------------------|-----------------------|-------|
| CAN Interface | Drop List | CAN Interface #1 | |
| Received Message Enabled | Drop List | False | |
| Received PGN | 0 to 65536 | Different for each | |
| Received Message Timeout | 0 to 60 000 ms | 0ms | |
| Specific Address that sends PGN | 0 to 255 | 254 (0xFE, Null Addr) | |
| Receive Transmit Data Size | Drop List | 2 bytes | |
| Receive Transmit Data Index in Array | 0-7 | 4 | |
| Receive Transmit Bit Index In Byte | 0-7 | 0 | |
| Receive Transmit Data Resolution | -100000.0 to 100000 | 0.001 | |
| Receive Transmit Data Offset | -10000 to 10000 | 0.0 | |
| Receive Data Min (Off Threshold) | -1000000 to Max | 0.0 | |
| Receive Data Max (On Threshold) | -100000 to 100000 | 2.0 | |

4.16. General Diagnostics Options

These setpoints control the shutdown of the ECU in case of a power supply or CPU temperature related errors. Refer to section 1.6 for more info.

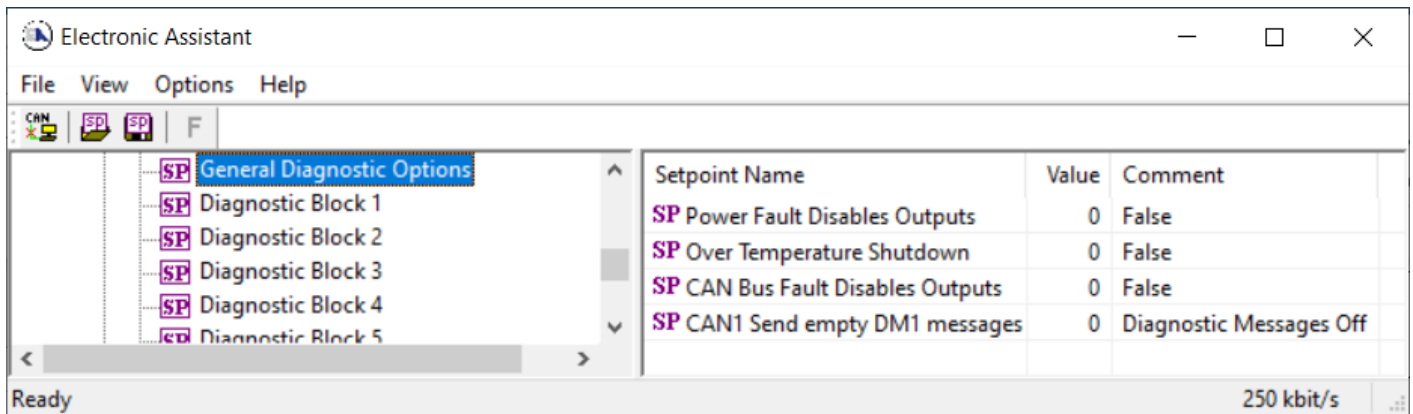

Figure 20 – Screen Capture of General Diagnostics Options Setpoints

Table 37 – General Diagnostics Options Setpoints

| Name | Range | Default | Notes |
|------------------------------|-----------|---------|-------|
| Power Fault Disables Outputs | Drop List | 0 | |
| Over Temperature Shutdown | Drop List | 0 | |

4.17. Diagnostics Blocks

There are 16 Diagnostics blocks that can be configured to monitor various parameters of the Controller. The Diagnostic Function Block is defined in section 1.6. Please refer there for detailed information how these setpoints are used.

| Setpoint Name | Value | Comment |
|--|-------|--|
| SP Fault Detection is Enabled | 1 | True |
| SP Function Type to Monitor | 0 | Control Not Used |
| SP Function Parameter to Monitor | | Parameter not used with current Function Type to Monitor |
| SP Enable Source | | Parameter not used with current Function Type to Monitor |
| SP Enable Number | | Parameter not used with current Function Type to Monitor |
| SP Enable Response | | Parameter not used with current Function Type to Monitor |
| SP Fault Detection Type | | Parameter not used with current Function Type to Monitor |
| SP Maximum Value for Diagnostic Data | | Parameter not used with current Function Type to Monitor |
| SP Minimum Value for Diagnostic Data | | Parameter not used with current Function Type to Monitor |
| SP Use Hysteresis When Defining Thresholds | | Parameter not used with current Function Type to Monitor |
| SP Hysteresis | | Parameter not used with current Function Type to Monitor |
| SP Event Cleared Only by DM11 | | Parameter not used with current Function Type to Monitor |
| SP Set Limit for MINIMUM WARNING | | Parameter not used with current Function Type to Monitor |
| SP Clear Limit for MINIMUM WARNING | | Parameter not used with current Function Type to Monitor |
| SP Set Limit for MAXIMUM WARNING | | Parameter not used with current Function Type to Monitor |
| SP Clear Limit for MAXIMUM WARNING | | Parameter not used with current Function Type to Monitor |
| SP Set Limit for MINIMUM SHUTDOWN | | Parameter not used with current Function Type to Monitor |
| SP Clear Limit for MINIMUM SHUTDOWN | | Parameter not used with current Function Type to Monitor |
| SP Set Limit for MAXIMUM SHUTDOWN | | Parameter not used with current Function Type to Monitor |
| SP Clear Limit for MAXIMUM SHUTDOWN | | Parameter not used with current Function Type to Monitor |
| SP MAXIMUM SHUTDOWN, Event Generates a DTC in DM1 | | Parameter not used with current Function Type to Monitor |
| SP MAXIMUM SHUTDOWN, Lamp Set by Event | | Parameter not used with current Function Type to Monitor |
| SP MAXIMUM SHUTDOWN, SPN for Event | | Parameter not used with current Function Type to Monitor |
| SP MAXIMUM SHUTDOWN, FMI for Event | | Parameter not used with current Function Type to Monitor |
| SP MAXIMUM SHUTDOWN, Delay Before Event is Flagged | | Parameter not used with current Function Type to Monitor |
| SP MAXIMUM WARNING, Event Generates a DTC in DM1 | | Parameter not used with current Function Type to Monitor |
| SP MAXIMUM WARNING, Lamp Set by Event | | Parameter not used with current Function Type to Monitor |
| SP MAXIMUM WARNING, SPN for Event | | Parameter not used with current Function Type to Monitor |
| SP MAXIMUM WARNING, FMI for Event | | Parameter not used with current Function Type to Monitor |
| SP MAXIMUM WARNING, Delay Before Event is Flagged | | Parameter not used with current Function Type to Monitor |
| SP MINIMUM WARNING, Event Generates a DTC in DM1 | | Parameter not used with current Function Type to Monitor |

Figure 21 – Screen Capture of Diagnostic Block Setpoints

Table 38 – Diagnostic Block Setpoints

| Name | Range | Default | Notes |
|--|---|-------------------------|--|
| Fault Detection is Enabled | Drop List | False | |
| Function Type to Monitor | Drop List | 0 – Control not used | |
| Function parameter to Monitor | Drop List | 0 – No selection | |
| Fault Detection Type | Drop List | 0 – Min and Max Error | See section 1.6 |
| Maximum Value for Diagnostic Data | Minimum Value for Diagnostic Data ... 4.28e ⁹ | 5.0 | |
| Minimum Value for Diagnostic Data | 0.0 ... Maximum Value for Diagnostic Data | 0.0 | |
| Use Hysteresis When Defining Thresholds | Drop List | False | |
| Hysteresis | 0.0 ... Maximum Value for Diagnostic Data | 0.0 | |
| Event Cleared only by DM11 | Drop List | False | |
| Set Limit for MAXIMUM SHUTDOWN | Minimum Value for Diagnostic Data ... Maximum Value for Diagnostics Data | 4.8 | |
| Clear Limit for MAXIMUM SHUTDOWN | Minimum Value for Diagnostic Data ... Maximum Value for Diagnostics Data | 4.6 | |
| Set Limit for MAXIMUM WARNING | Minimum Value for Diagnostic Data ... Maximum Value for Diagnostics Data | 0.0 | |
| Clear Limit for MAXIMUM WARNING | Minimum Value for Diagnostic Data ... Maximum Value for Diagnostics Data | 0.0 | |
| Clear Limit for MINIMUM WARNING | Minimum Value for Diagnostic Data ... Maximum Value for Diagnostics Data | 0.0 | |
| Set Limit for MINIMUM WARNING | Minimum Value for Diagnostic Data ... Maximum Value for Diagnostics Data | 0.0 | |
| Clear Limit for MINIMUM SHUTDOWN | Minimum Value for Diagnostic Data ... Maximum Value for Diagnostics Data | 0.4 | |
| Set Limit for MINIMUM SHUTDOWN | Minimum Value for Diagnostic Data ... Maximum Value for Diagnostics Data | 0.2 | |
| MAXIMUM SHUTDOWN, Event Generates a DTC in DM1 | Drop List | True | |
| MAXIMUM SHUTDOWN, Lamp Set by Event | Drop List | 0 – Protect | See Table 12 |
| MAXIMUM SHUTDOWN, SPN for Event | 0...524287 | 520448 (\$7F100) | It is the user's responsibility to select an SPN that will not violate the J1939 standard. |
| MAXIMUM SHUTDOWN, FMI for Event | Drop List | 3, Voltage Above Normal | See Table 13 |

| | | | |
|---|--------------|-------------------------|--|
| MAXIMUM SHUTDOWN, Delay Before Event is Flagged | 0...60000 ms | 1000 | |
| MAXIMUM WARNING, Event Generates a DTC in DM1 | Drop List | True | |
| MAXIMUM WARNING, Lamp Set by Event | Drop List | 0 – Protect | See Table 12 |
| MAXIMUM WARNING, SPN for Event | 0...524287 | 520704 (\$7F200) | It is the user's responsibility to select an SPN that will not violate the J1939 standard. |
| MAXIMUM WARNING, FMI for Event | Drop List | 3, Voltage Above Normal | See Table 13 |
| MAXIMUM WARNING, Delay Before Event is Flagged | 0...60000 ms | 1000 | |
| MINIMUM WARNING, Event Generates a DTC in DM1 | Drop List | True | |
| MINIMUM WARNING, Lamp Set by Event | Drop List | 0 – Protect | See Table 12 |
| MAXIMUM WARNING, SPN for Event | 0...524287 | 520960 (\$7F300) | It is the user's responsibility to select an SPN that will not violate the J1939 standard. |
| MINIMUM WARNING, FMI for Event | Drop List | 4, Voltage Below Normal | See Table 13 |
| MINIMUM WARNING, Delay Before Event is Flagged | 0...60000 ms | 1000 | |
| MINIMUM SHUTDOWN, Event Generates a DTC in DM1 | Drop List | True | |
| MINIMUM SHUTDOWN, Lamp Set by Event | Drop List | Amber Warning | See Table 12 |
| MINIMUM SHUTDOWN, SPN for Event | 0...524287 | 521216 (\$7F400) | It is the user's responsibility to select an SPN that will not violate the J1939 standard. |
| MINIMUM SHUTDOWN, FMI for Event | Drop List | 4, Voltage Below Normal | See Table 13 |
| MINIMUM SHUTDOWN, Delay Before Event is Flagged | 0...60000 ms | 1000 | |

4.18. DTC React Function Block

The DTC React function block is described in Section 1.13. The Figure below shows the DTC React function block setpoints. The Table below show the default values. Please note: *The setpoint “DTC React is Enabled” was changed to 1, True.*

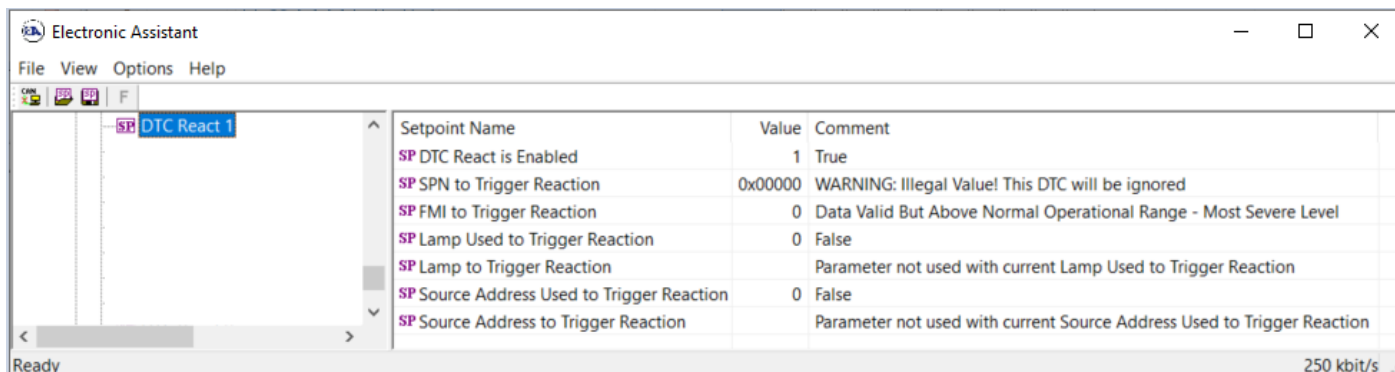

Figure 22 – TC React Setpoints

Table 39 – DTC React Setpoints

| Name | Range | Default | Notes |
|---|-----------------|------------|-------|
| DTC React is Enabled | Drop List | 0, False | |
| SPN to Trigger Reaction | 0x00 to 0x3FFFF | 0 | |
| FMI to Trigger Reaction | Drop List | 0 | |
| Lamp Used to Trigger Reaction | Drop list | 0, False | |
| Lamp to Trigger Reaction | Drop List | 0, Protect | |
| Source Address Used to Trigger Reaction | Drop list | 0, False | |
| Source Address to Trigger Reaction | 0x00 to 0xFF | 0 | |

5. REFLASHING OVER CAN WITH EA BOOTLOADER

The AX030780 can be upgraded with new application firmware using the **Bootloader Information** section. This section details the simple step-by-step instructions to upload new firmware provided by Axiomatic onto the unit via CAN, without requiring it to be disconnected from the J1939 network.

Note: To upgrade the firmware use Axiomatic Electronic Assistant V5.18.149.0 or higher.

1. When EA first connects to the ECU, the **Bootloader Information** section will display the following information.
2. To use the bootloader to upgrade the firmware running on the ECU, change the variable “**Force Bootloader To Load on Reset**” to Yes.

The screenshot shows the Electronic Assistant software interface. The left sidebar displays a tree view with the following items: J1939 CAN Network, ECU AX130780, 1 Digital Input, 2 HSLs Proport, General ECU Information, Setpoint File, and Bootloader Information (highlighted). The main area shows a table of parameters and their values:

| Parameter | Value |
|--|--|
| Hardware ID | 25005 |
| Hardware Revision Number | 1.00 |
| Hardware Compatibility Level | 1.00 |
| Hardware Description | PCB-25005-01-R1.scm |
| Bootloader ID | 25005 |
| Bootloader Version Number | 99.99 |
| Bootloader Compatibility Level | 1.00 |
| Bootloader Description | 1DIN-4OUT-CAN-12PIN-US Bootloader |
| Bootloader ECU Address | 253 |
| Force Bootloader to Load on Reset | No |
| Application Firmware ID | 25005 |
| Application Firmware Version Number | 99.99 |
| Application Firmware Compatibility Level | 1.00 |
| Application Firmware Description | 1 Digital Input, 4 Proportional Outputs CAN Controller |
| Application Firmware Flash File | AF-25005-v99.99_2025-06-19.bin |
| Application Firmware Flashing Date | June 20, 2025, 12:12 PM |
| Application Firmware Flashing Tool | Electronic Assistant 5.18.147.0, March 2025 |
| Application Firmware Flashing Comments | |

The status bar at the bottom indicates 'Ready' and '250 kbit/s'.

The dialog box titled "Force Bootloader to Load on Reset Setup" contains the following elements:

- A dropdown menu for "Force Bootloader to Load on Reset" currently set to "1 - Yes".
- The text "Default Value: 1 - Yes" below the dropdown.
- A "Set Default" button to the right of the default value.
- "OK" and "Cancel" buttons at the bottom.

3. When the prompt box asks if you want to reset the ECU, select Yes.

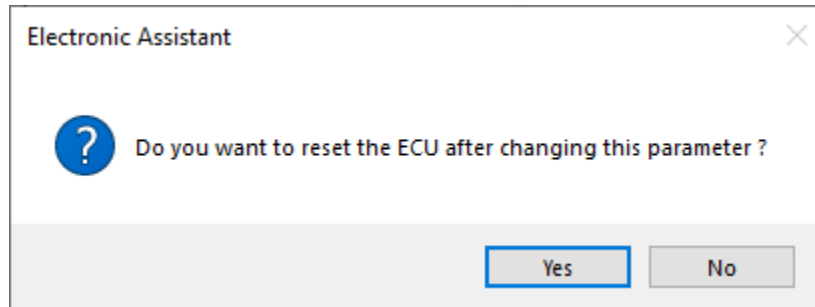

4. Upon reset, the ECU will no longer show up on the J1939 network as an AX030780 but rather as **J1939 Bootloader #1**.

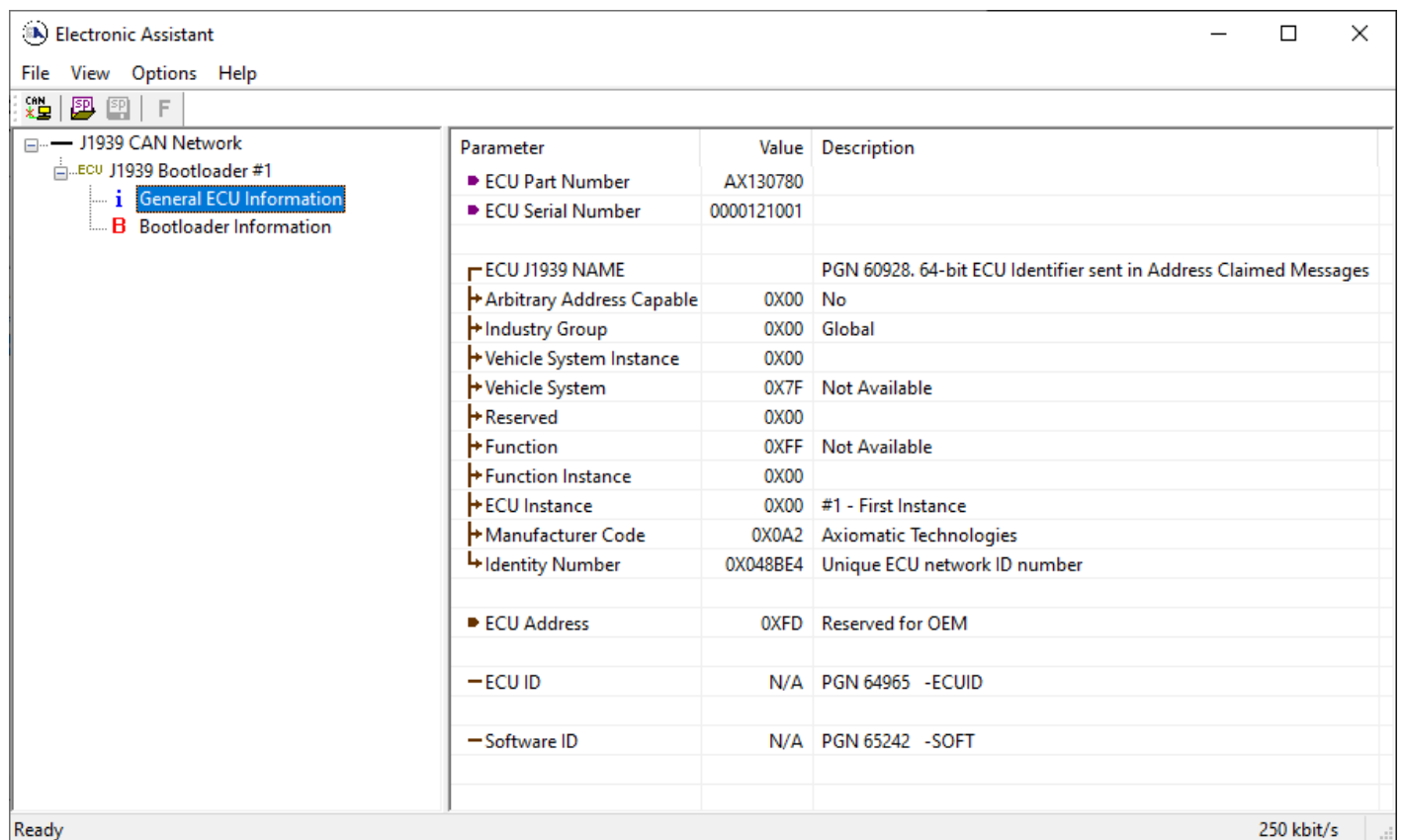
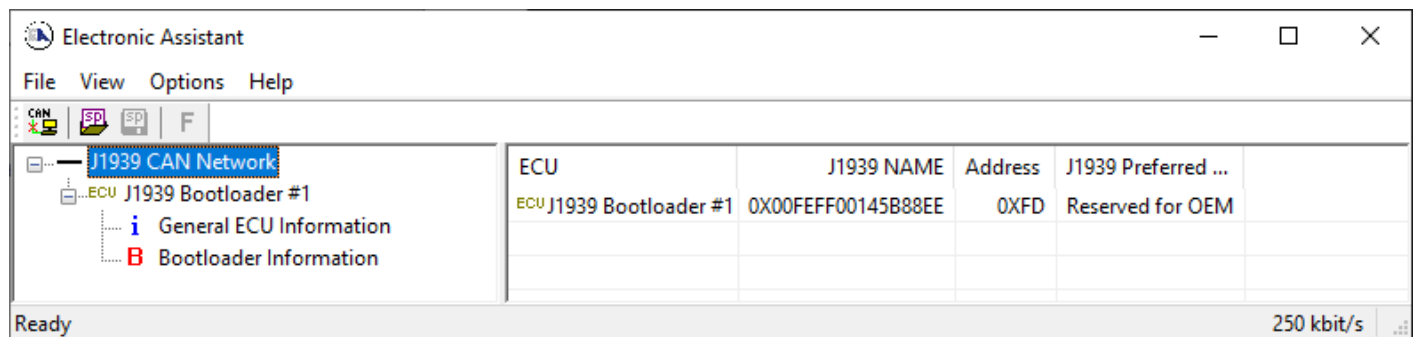

Note that the bootloader is NOT Arbitrary Address Capable. This means that if you want to have multiple bootloaders running simultaneously (not recommended) you would have to manually change the address for each one before activating the next, or there will be address conflicts. And only one ECU would show up as the bootloader. Once the 'active' bootloader returns to regular functionality, the other ECU(s) would have to be power cycled to re-activate the bootloader feature.

- When the **Bootloader Information** section is selected, the same information is shown as when it was running the AX030780 firmware, but in this case the **Flashing** feature has been enabled.

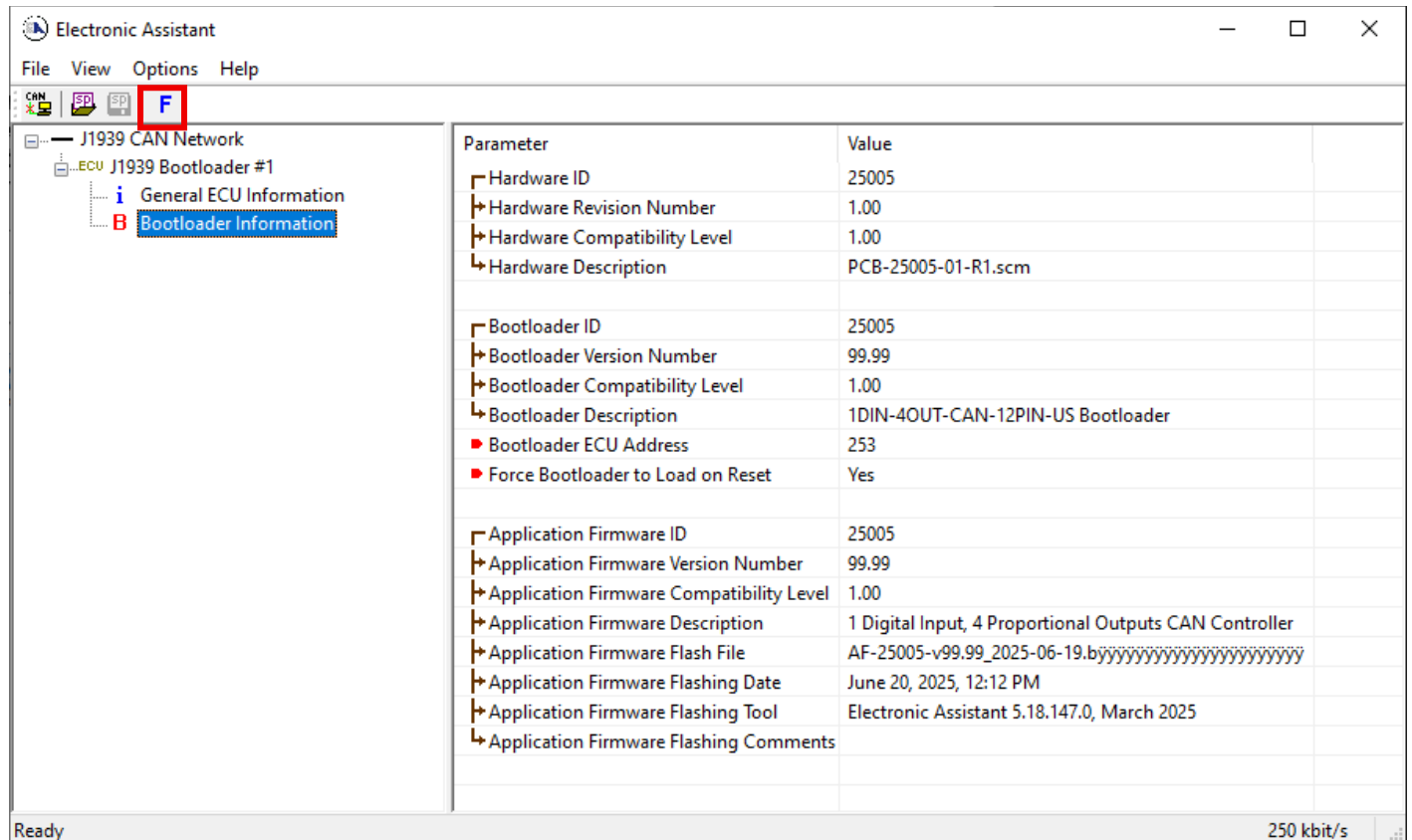

- Select the **Flashing** button and navigate to where you had saved the **AF-25005-VX.XX.bin** file sent from Axiomatic. (Note: only binary (.bin) files can be flashed using the EA tool.)

7. Once the Flash Application Firmware window opens, you can enter comments such as “Firmware upgraded by [Name]” if you so desire. This is not required, and you can leave the field blank if you do not want to use it.

Note: You do not have to date/timestamp the file, as this is done automatically by the EA tool when you upload the new firmware.

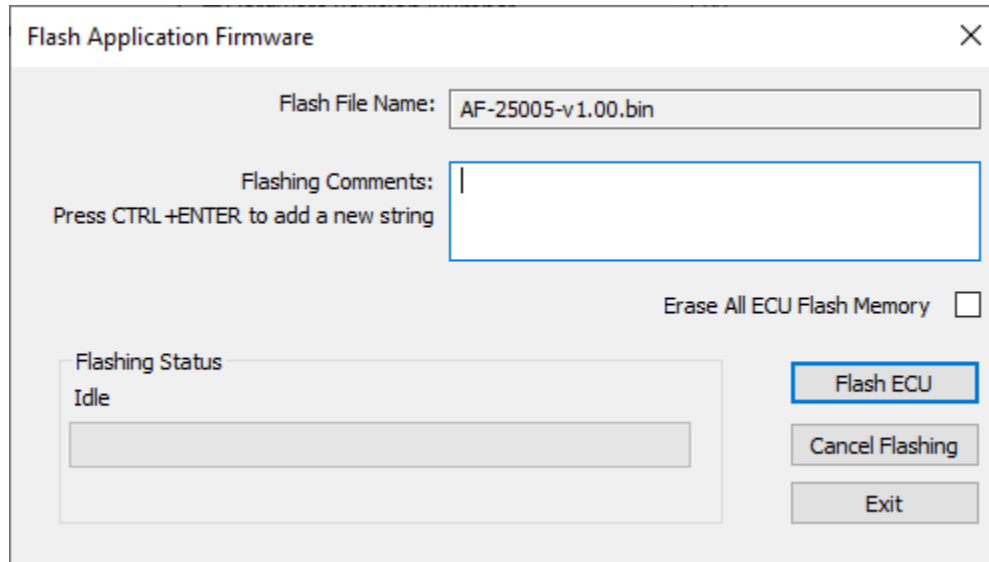

WARNING: Do not check the “Erase All ECU Flash Memory” box unless instructed to do so by your Axiomatic contact. Selecting this will erase ALL data stored in non-volatile flash, including the calibration done by Axiomatic during factory testing. It will also erase any configuration of the setpoints that might have been done to the ECU, and reset all setpoints to their factory defaults. By leaving this box unchecked, none of the setpoints will be changed when the new firmware is uploaded.

A progress bar will show how much of the firmware has been sent as the upload progresses. The more traffic there is on the J1939 network, the longer the upload process will take.

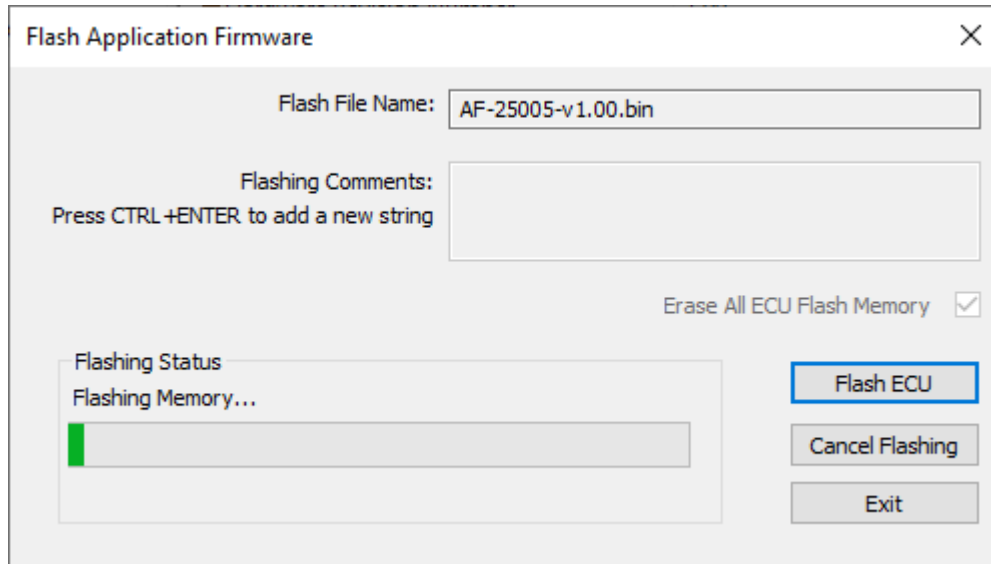

Once the firmware has finished uploading, a message will pop up indicating the successful operation. If you select to reset the ECU, the new version of the AX030780 application will start running, and the ECU will be identified as such by EA. Otherwise, The next time the ECU is power-cycled, the AX030780 application will run rather than the bootloader function.

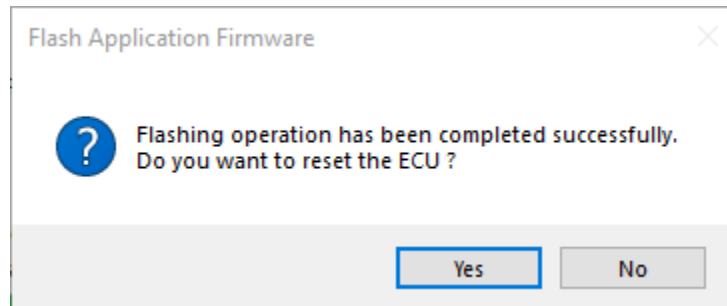

Note: If at any time during the upload the process is interrupted, the data is corrupted (bad checksum) or for any other reason the new firmware is not correct, i.e. bootloader detects that the file loaded was not designed to run on the hardware platform, the bad or corrupted application will not run. Rather, when the ECU is reset or power-cycled the **J1939 Bootloader** will continue to be the default application until valid firmware has been successfully uploaded into the unit.

APPENDIX A - TECHNICAL SPECIFICATION

Specifications are indicative and subject to change. Actual performance will vary depending on the application and operating conditions. Users should satisfy themselves that the product is suitable for use in the intended application. All our products carry a limited warranty against defects in material and workmanship. Please refer to our Warranty, Application Limitations & Return Materials Process as described on <https://www.axiomatic.com/service/>.

Power

| | |
|-------------------|---|
| Power Input | 12 or 24 VDC (nominal) 7 to 46 VDC range |
| Quiescent Current | TBD mA @ 12 VDC; TBD mA @ 24 VDC (typical) |
| Protections | Surge and transient protection is provided. Reverse polarity protection up to -80 VDC is provided. Undervoltage protection is provided. Hardware shutdown at 6 V. Overvoltage protection is provided. Hardware shutdown at 47 V. |

Input

| | |
|---------------|--|
| Digital Input | 1x isolated digital input Low: 13.6 V High: 14.3 V Input impedance: 12 K Ω |
|---------------|--|

Outputs

| | | |
|---|--|--|
| H-Bridge, Proportional, or Digital Outputs | 2x outputs programmable as follows. | |
| | <ul style="list-style-type: none"> 2x proportional / digital outputs 1x full H-bridge ± 5 A output (Load connected between "Proportional / Digital Output 1" and "Proportional / Digital Output 2") | |
| | The proportional outputs are further configurable as follows. | |
| | Proportional Voltage | Range: 0 to Vps Resolution: 100 mV Accuracy: ± 1 % error |
| | Proportional Current | Ranges: Up to ± 5 A Resolution: 1 mA Accuracy: ± 1 % error |
| | Hotshot Digital | Ranges: Up to ± 5 A Resolution: 1 mA Accuracy: ± 1 % error See profile diagram below. |
| | PWM | Range: 1 Hz to 25 kHz Duty Cycle: 0 to 100 % Resolution: 0.1 % Accuracy: ± 1 % error Amplitude: Vps ± 0.5 % |
| Digital On/Off | ON = Vps ± 0.5 % OFF = 0 V | |
| Disabled Output | - | |
| Load at supply voltage must not draw more than 5 A. | | |
| Analog Outputs | 2x analog outputs configurable as voltage or current type. | |
| | Analog Voltage | Ranges: 0 to 5 V, 0 to 10 V, -5 to 5 V, or -10 to 10 V Resolution: 0.01 V Accuracy: ± 0.5 % error Maximum Load: 30 mA |
| | Analog Current | Ranges: 0 to 20 mA or 4 to 20 mA Resolution: 0.01 mA Accuracy: ± 0.5 % error Maximum Load Resistance: 400 Ω |
| 12-bit Digital-to-Analog Converter (DAC) | | |
| Protection | Protected against shorts to Ground or Battery +. | |

General Specifications

| | |
|------------------------|---|
| Microcontroller | STM32H725RGV3 |
| Communications | 1x CAN port (SAE J1939) Supported baud-rates: 250 kbit/s, 500 kbit/s, 667 kbit/s, and 1 Mbit/s with auto-baud-rate detection |
| User Interface | Axiomatic Electronic Assistant P/N: AX070506K |
| Compliance | RoHS |
| Operating Conditions | -40 to 85 °C (-40 to 185 °F) |
| Storage Temperature | -40 to 105 °C (-40 to 221 °F) |
| Weight | TBD lb. (TBD kg) |
| Protection Rating | IP67 |
| Enclosure | Molded Enclosure, integral connector Nylon 6/6, 30% glass, laser welded Flammability rating: UL 94 HB 4.2 in. x 3.7 in. x 1.4 in. (107.4 mm x 93.5 mm x 35.8 mm) Note: L x W x H includes the integral connector Refer to Dimensional Drawing. |
| Electrical Connections | Integral 12-pin receptacle (equivalent to TE Deutsch P/N: DTM04-12PA) |
| Mating Connectors | Mating Plug KIT P/N: PL-DTM06-12SA (includes 1x DTM06-12SA plug, 1x WM-12S wedgelock, 12x 0462-201-20141 solid contacts, and 6x 0413-204-2005 sealing plugs) |
| Mounting | Mounting holes are sized for #10 or M5 bolts. The bolt length will be determined by the end-user's mounting plate thickness. The mounting flange of the controller is 0.47 in. (12 mm) thick. It should be mounted with connectors facing left or right to reduce likelihood of moisture entry. All field wiring should be suitable for the operating temperature range. Install the unit with appropriate space available for servicing and for adequate wire harness access (6 in. or 15 cm) and strain relief (12 in. or 30 cm). |

OUR PRODUCTS

AC/DC Power Supplies
Actuator Controls/Interfaces
Automotive Ethernet Interfaces
Battery Chargers
CAN Controls, Routers, Repeaters
CAN/WiFi, CAN/Bluetooth, Routers
Current/Voltage/PWM Converters
DC/DC Power Converters
Engine Temperature Scanners
Ethernet/CAN Converters,
Gateways, Switches
Fan Drive Controllers
Gateways, CAN/Modbus, RS-232
Gyroscopes, Inclinometers
Hydraulic Valve Controllers
Inclinometers, Triaxial
I/O Controls
LVDT Signal Converters
Machine Controls
Modbus, RS-422, RS-485 Controls
Motor Controls, Inverters
Power Supplies, DC/DC, AC/DC
PWM Signal Converters/Isolators
Resolver Signal Conditioners
Service Tools
Signal Conditioners, Converters
Strain Gauge CAN Controls
Surge Suppressors

OUR COMPANY

Axiomatic provides electronic machine control components to the off-highway, commercial vehicle, electric vehicle, power generator set, material handling, renewable energy and industrial OEM markets. ***We innovate with engineered and off-the-shelf machine controls that add value for our customers.***

QUALITY DESIGN AND MANUFACTURING

We have an ISO9001:2015 registered design/manufacturing facility in Canada.

WARRANTY, APPLICATION APPROVALS/LIMITATIONS

Axiomatic Technologies Corporation reserves the right to make corrections, modifications, enhancements, improvements, and other changes to its products and services at any time and to discontinue any product or service without notice. Customers should obtain the latest relevant information before placing orders and should verify that such information is current and complete. Users should satisfy themselves that the product is suitable for use in the intended application. All our products carry a limited warranty against defects in material and workmanship. Please refer to our Warranty, Application Approvals/Limitations and Return Materials Process at <https://www.axiomatic.com/service/>.

COMPLIANCE

Product compliance details can be found in the product literature and/or on axiomatic.com. Any inquiries should be sent to sales@axiomatic.com.

SAFE USE

All products should be serviced by Axiomatic. Do not open the product and perform the service yourself.



This product can expose you to chemicals which are known in the State of California, USA to cause cancer and reproductive harm. For more information go to www.P65Warnings.ca.gov.

SERVICE

All products to be returned to Axiomatic require a Return Materials Authorization Number (RMA#) from rma@axiomatic.com. Please provide the following information when requesting an RMA number:

- Serial number, part number
- Runtime hours, description of problem
- Wiring set up diagram, application and other comments as needed

DISPOSAL

Axiomatic products are electronic waste. Please follow your local environmental waste and recycling laws, regulations and policies for safe disposal or recycling of electronic waste.

CONTACTS

Axiomatic Technologies Corporation
1445 Courtneypark Drive E.
Mississauga, ON
CANADA L5T 2E3
TEL: +1 905 602 9270
FAX: +1 905 602 9279
www.axiomatic.com
sales@axiomatic.com

Axiomatic Technologies Oy
Höytämöntie 6 C
33880 Lempäälä
FINLAND
TEL: +358 10 337 5751
www.axiomatic.com
salesfinland@axiomatic.com