



USER MANUAL UMAXRTD8CO

RTD SCANNER, EIGHT CHANNEL

With CANopen®

USER MANUAL

P/N: AXRTD8CO

In Europe:
Axiomatic Technologies Oy
Höytämöntie 6
33880 LEMPÄÄLÄ - Finland
Tel. +358 3 3595 600
Fax. +358 3 3595 660
www.axiomatic.fi

In North America:
Axiomatic Technologies Corporation
5915 Wallace Street
Mississauga, ON Canada L4Z 1Z8
Tel. 1 905 602 9270
Fax. 1 905 602 9279
www.axlomatic.com

VERSION HISTORY

Version	Date	Author	Modifications
1.0.0	August 13, 2010	Anna Murray	Initial Draft
1.0.1	November 10, 2010	Anna Murray	Changed fixed width of RS-232 data stream from 5 to 6 characters. Updated screen capture
-	November 19, 2010	Amanda Wilkins	Changed optical isolation to digital isolation
1.1.0	January 25, 2011	Anna Murray	Added new object 5555h
2.0.0	December 19, 2011	Amanda Wilkins	New hardware – updated with certifications
2.1.0	April 26, 2012	Anna Murray	Updated section 4.1.5 for Load New Software to reflect the new bootloader.
2.1.1	October 9, 2012	Amanda Wilkins	Added input resistance range and clarified isolation.
2.1.1A	April 2, 2014	Olek Bogush	Added “Short Circuit” and “Open Circuit” conditions to the Technical Specification.
2.1.1A	October 2, 2015	Amanda Wilkins	Updated IP rating to IP67 based on test results

ACRONYMS

AVG	Average
CAN	Controller Area Network
CANopen®	CANopen® is a registered community trademark of CAN in Automation e.V.
CAN-ID	CAN 11-bit Identifier
CJ	Cold Junction
COB	Communication Object
EDS	Electronic Data Sheet
EMCY	Emergency
LSB	Least Significant Byte (or Bit)
LSS	Layer Settling Service
MSB	Most Significant Byte (or Bit)
MEMS	Micro-electromechanical system
NMT	Network Management
RO	Read Only Object
RPDO	Received Process Data Object
RTD	Resistive Thermal Device
RW	Read/Write Object
SDO	Service Data Object
TPDO	Transmitted Process Data Object
WO	Write Only Object

REFERENCES

- [DS-301] CiA DS-301 V4.1 – CANopen Application Layer and Communication Profile. CAN in Automation 2005
- [DS-305] CiA DS-305 V2.0 – Layer Setting Service (LSS) and Protocols. CAN in Automation 2006
- [DS-404] CiA DS-404 V1.2 – CANopen profile for Measurement Devices and Closed Loop Controllers. CAN in Automation 2002

These documents are available from the CAN in Automation e.V. website <http://www.can-cia.org/>.

TABLE OF CONTENTS

1. OVERVIEW OF RTD SCANNER	5
1.1. Description of RTD Scanner.....	5
1.2. RTD Measurements.....	7
1.3. Average Measurements.....	10
2. INSTALLATION INSTRUCTIONS	11
2.1. Dimensions and Pinout.....	11
2.2. Installation Instructions	13
3. CANOPEN® OBJECT DICTIONARY	16
3.1. NODE ID and BAUDRATE.....	16
3.1.1. LSS Protocol to Update.....	16
3.2. COMMUNICATION OBJECTS (DS-301 and DS-404).....	20
3.2.1. Object 1000h: Device Type.....	21
3.2.2. Object 1001h: Error Register.....	22
3.2.3. Object 1002h: Manufacturer Status Register.....	22
3.2.4. Object 1003h: Pre-Defined Error Field.....	22
3.2.5. Object 100Ch: Guard Time.....	24
3.2.6. Object 100Dh: Lifetime Factor.....	24
3.2.7. Object 1010h: Store Parameters.....	25
3.2.8. Object 1011h: Restore Parameters.....	26
3.2.9. Object 1016h: Consumer Heartbeat Time.....	28
3.2.10. Object 1017h: Producer Heartbeat Time.....	29
3.2.11. Object 1018h: Identity Object.....	29
3.2.12. Object 1020h: Verify Configuration.....	30
3.2.13. Object 1029h: Error Behaviour.....	31
3.2.14. RPDO Behaviour	32
3.2.15. TPDO Behaviour.....	34
3.3. APPLICATION OBJECTS (DS-404).....	36
3.3.1. Object 6100h: RTD Input Field Value.....	36
3.3.2. Object 6110h: RTD Sensor Type.....	37
3.3.3. Object 6112h: RTD Operating Mode.....	37
3.3.4. Object 6114h: ADC Sample Rate.....	38
3.3.5. Object 6126h: RTD Scaling Factor.....	39
3.3.6. Object 6127h: RTD Scaling Offset.....	39
3.3.7. Object 7130h: RTD Input Process Value.....	40
3.3.8. Object 6150h: RTD Status.....	40

3.4.	MANUFACTURER OBJECTS.....	42
3.4.1.	Object 2000h: RTD Resistance.....	42
3.4.2.	Object 2010h: RTD Microvolts.....	43
3.4.3.	Object 2100h: Average Input Field Value.....	43
3.4.4.	Object 2112h: Average Operating Mode.....	44
3.4.5.	Object 2126h: Average Scaling Factor.....	45
3.4.6.	Object 2127h: Average Scaling Offset.....	46
3.4.7.	Object 2130h: Average Input Process Value.....	47
3.4.8.	Object 3000h: RTD Coefficient.....	48
3.4.9.	Object 3010h: Callendar Van Dusen Constant A.....	48
3.4.10.	Object 3020h: Callendar Van Dusen Constant B.....	49
3.4.11.	Object 3030h: Callendar Van Dusen Constant C.....	50
3.4.12.	Object 4000h: Low Temperature Warning Threshold.....	51
3.4.13.	Object 4010h: High Temperature Warning Threshold.....	51
3.4.14.	Object 4020h: High Temperature Shutdown Threshold.....	52
3.4.15.	Object 4030h: Error React Delay.....	52
3.4.16.	Object 5000h: Power Supply Measured.....	53
3.4.17.	Object 5001h: Current Source Measured.....	53
3.4.18.	Object 5010h: ADC Filter Frequency.....	54
3.4.19.	Object 5555h: Start in Operational.....	54
4.	USING RS-232 WITH TERA TERM	55
4.1.	Main Menu Options.....	56
4.1.1.	V – View Object Dictionary.....	57
4.1.2.	D – Default Object Dictionary.....	58
4.1.3.	T – Toggle RS-232 Stream Off/On.....	58
4.1.4.	S – Show/Stop Diagnostics.....	59
4.1.5.	L – Load New Software.....	59
	APPENDIX A – Technical Specifications.....	A
	LIST OF FIGURES	
1.	Resistive Input Wiring and Measurement.....	5
2.	RTD Input Block Diagram.....	7
2.	Average Measurement Block Diagram.....	10
	LIST OF TABLES	
1.	Callendar-Van Dusen Constants for Standard RTD Coefficients.....	8
2.	LSS Baudrate Indexes.....	18
3.	Error Descriptions.....	23
4.	EMCY Error Codes.....	23
5.	Supported RTD Types.....	37
6.	RTD Status Values.....	40
7.	Supported RTD Coefficients.....	48

1. OVERVIEW OF RTD SCANNER

1.1. Description of RTD Scanner

The following User Manual describes the architecture and functionality of a eight channel CANopen® RTD scanner.

There are eight channels on the AXRTD8, each with four pins at the connector for 2, 3 or 4 wire connections, as well as a fifth pin for a shield. The RTD scanner will source current on pin A for all types of RTD sensors.

In the case of a 2-wire device, it will read the voltage between Pin A and GND, with no compensation for any resistance added by the wires. For 3-wire devices, it reads the voltage at Pin A, as well as that at Pin C. The Pin C reading will allow the device to calculate the approximate resistance in one wire, and will subtract twice that value from the calculated resistance based on the voltage measure at A. Lastly, for 4-wire devices, it will read the voltage at Pin B which already takes into account the resistance of the wire from A. It will also measure the voltage at Pin C to calculate the return wire resistance, and subtract that from the measured value at B.

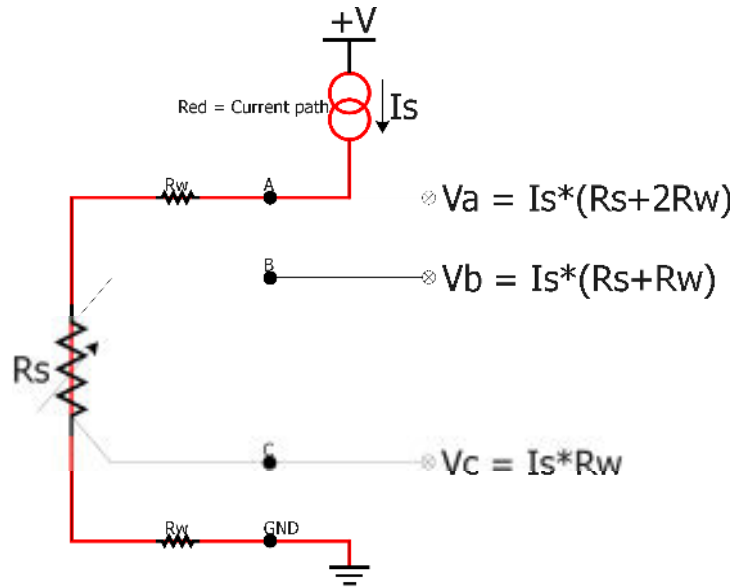

$$\text{2-Wire: } R_s = V_a / I_s - 2R_w$$

$$\begin{aligned} \text{3-Wire: } V_a - 2V_c &= I_s R_s + 2I_s R_w - 2I_s R_w \\ R_s &= (V_a - 2V_c) / I_s \end{aligned}$$

$$\begin{aligned} \text{4-Wire: } V_b - V_c &= I_s R_s + I_s R_w - I_s R_w \\ R_s &= (V_b - V_c) / I_s \end{aligned}$$

Figure 1 – Resistive Input Wiring and Measurement

In the case of a 4 wire RTD, if the wire to A is broken, the unit will report the load a short circuited because there will be no voltage on Pin B.

All channels are fully isolated from the CAN lines, and from the power supply. The power supply was designed for a wide range of nominal inputs of 12V, 24V or 48V and will provide proper operation from 9 to 60Vdc.

If desired, the average temperature of all the active channels, or all channels from a block of 4, can be broadcasted to the network using the Average Input function block. This feature is described in detail in section 1.3.

On power-up, the AXRTD8CO will immediately send the bootup message to the network. However, in order to prevent erroneous readings before all the data from all channels have been read correctly, the unit will only start broadcasting diagnostic data after 5 seconds have elapsed, and will not enter "Operational" mode during this period.

To measure voltages, the AXRTD8CO uses a very precise (24bit) dual channel analog-to-digital converter with a programmable gain. The RTD inputs and the current source (common to all 8 inputs) are multiplexed to the ADC chip. It has a programmable filtering for either 50Hz or 60Hz. The ADC provides a minimum 100dB normal mode rejection of the line frequency and its harmonics.

Active channels are scanned sequentially (1 to 8) with approximately 100ms between readings. For 2-wire types, there is one reading per channel, whereas 3 or 4 wire types require two readings per channel. On every read-thru of the channels, there is also a measurement taken of the common current source used to generate the voltage on each channel.

For 3 or 4 wire type channels, the wire resistance is only checked after 600 reads from the AtoD, since it does not change that frequently. This means the wire resistance is read and update once a minute.

If all 8 channels are active, it takes approximately 900ms to read through all the channels, and the current source. Therefore, any individual channel's reading is updated at least once per second, less if not all channels are active.

Temperature is measured in °C, with a 0.1°C resolution. When installed properly, as described in section 2.2, the scanner will send temperatures with +/- 1°C accuracy typical at ambient temperature.

The scanner can be used to flag low temperature warnings, high temperature warnings, or high temperature shutdowns. It will also detect and flag open or short circuits on the sensor wires.

1.2. RTD Measurements

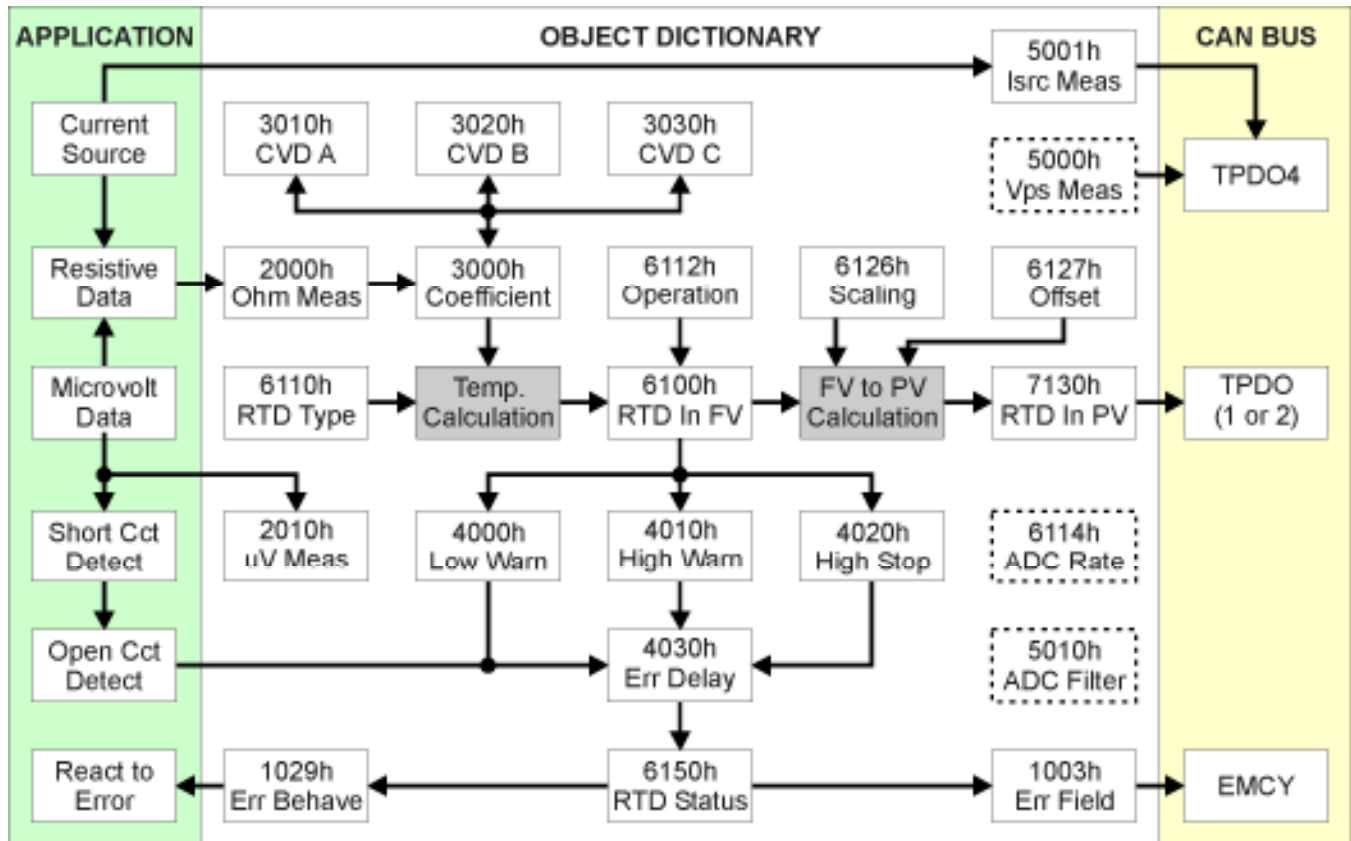

Figure 2 – RTD Input Block Diagram

The block diagram shown in Figure 2 capture the objects associated with each RTD channel. Each channel, 1 through 8, operates in the same fashion as described below.

In order to generate a measurable voltage across each resistive sensor, the scanner multiplexes an ~4mA current source to each input and reads the voltage generated. (See Figure 1 for more information.) In order to accurately calculate the resistance from the voltage, the scanner also multiplexes this source across a fixed reference resistor in order to know exactly what current is sourced to each channel. The actual current source value is available on read-only object \$5001 **Current Source Measured**. By default, this object, along with read-only object \$5000 **Power Supply Measured**, are mapped to TPD04.

Objects \$3000h **RTD Coefficient**, \$6110 **RTD Sensor Type** and \$6112 **RTD Operating Mode** determine how the scanner processes the raw microvolt reading and converts it into a temperature value in degrees Celsius, which is written to read-only object \$6100 **RTD Input Field Value**.

The resistance of the sensor is calculated based on the sensor type selected (2-wire, 3-wire or 4-wire) as per the formulas shown in Figure 1. The RTD Scanner then calculates the temperature from the measured resistance using the Callendar-Van Dusen constants.

According to IEC751, the non-linearity of the platinum thermometer can be expressed as:

$$R_t = R_0[1 + At + Bt^2 + C(t-100)t^3] \text{ in which } C \text{ is only applicable when } t < 0 \text{ } ^\circ\text{C}.$$

Depending on the value in object \$3000, the objects \$3010, \$3020 and \$3030 **Callendar-Van Dusen Constant A, B and C** are automatically updated as necessary. The constants A, B, and C for a standard sensor are stated in IEC751, and the values used by the scanner are listed below.

Sensor Coefficient	Constant A [E-03]	Constant B [E-07]	Constant C [E-12]
IEC 00385	3.908300	-5.77500	-4.18301
JIS 003916	3.974673	-5.89730	-4.35300
US 003902	3.960000	-5.93000	-4.30000
Legacy US 003920	3.984800	-5.87000	-4.00000
SAMA 003923	3.981531	-5.853116	-4.35453

Table 1 – Callendar-Van Dusen Constants for Standard RTD Coefficients

Generally speaking, the Callendar-Van Dusen objects are treated as read-only variables. However, should a “User Defined” coefficient be selected, these objects would become write-able in order to allow for RTD sensors not listed in the above table to be connected.

Objects \$6126 **RTD Scaling Factor** and \$6127 **RTD Scaling Offset** are used to convert the field value to read-only object \$7130 **RTD Input Process Value**, which is mapped either to TPDO1 (1 to 4) or TPDO2 (5 to 8) by default.

The formula to convert the field value (FV) to process value (PV) is:

$$\text{Process Value} = (\text{Field Value} * \text{Scaling Factor}) + \text{Scaling Offset}$$

While the FV is a real number, containing the temperature in °C, the PV is a 16-bit integer value. The default scaling has been selected such that the PV will send the temperature with a resolution of 0.0625 °C/bit and a offset of -273°C. [Scaling Factor = 16, Offset = 4368] Since the maximum temperature the scanner can measure for a RTD is 1735°C, this means the range of the PV data will be 0 to 32123 (-273°C to 1735°C.)

Alternatively, it may be desired to send the temperature in Fahrenheit with a 0.1°F resolution per bit. In this case, the Scaling Factor would be set to 18, and the Offset to 320. Other scaling can be selected as desired by the user.

In all cases, certain values will be ‘plugged’ into the PV object to indicate various conditions. Should the associated RTD be disabled by object \$6112, then the value in the PV will always be -1 (0xFFFF).

Alternatively, should the scanner detect an open circuit on the sensor, then the PV value will be set to -512 (0xFE00). A short circuit on the sensor returns a PV value of -448 (0xFE40). Lastly, in the unlikely case that the processor detects that the ADC converter has stopped working (i.e. no longer sending updated data on every scan), then the controller will not continue to broadcast the ‘frozen’ data, but rather update the PV value to -384 (0xFE80) to indicate that there is a problem with the measurement.

In both error conditions mentioned above, open circuit or frozen data, the associated object \$6150 **RTD Status** will also be updated to reflect the problem. Other faults that the scanner can detect and flag are determined by the values in objects \$4000 **Low Temperature Warning Threshold**, \$4010 **High Temperature Warning Threshold** and \$4020 **High Temperature Shutdown Threshold**.

The threshold values are always measured with respect to the field value, and have a fixed resolution of 0.1°C/bit. For example, a value of 1250 in object \$4010 means that any measured temperature greater than or equal to 125°C will flag a high temperature warning. The fault detection thresholds also have a fixed 1°C built-in hysteresis to clear them. In the example above, the temperature would have to drop below 124°C to clear the fault once it has been set.

Finally, in order to prevent flooding the network with emergency messages when the temperature hovers around a warning threshold, the object \$4030 **Error React Delay** allows the user to select how long the fault condition must be present before the status object is updated and the error reaction is triggered.

Once the status object shows that the FV value is no longer valid, the object \$1003 **Pre-Defined Error Field** is updated to reflect the appropriate emergency error code and additional information. Since both a high temperature warning and shutdown could be active at the same time, object \$1003 could have up to 16 entries at any given time. Also, when a sensor error is activated, the controller will react as specified in object \$1029 **Error Behaviour**.

The error values loaded in the status object \$6150 are described in Table 6, while the associated emergency fields that are loaded into object \$1003 are outlined in Table 4.

A couple of other miscellaneous objects associated with the RTD channels are three read-only objects \$2000 **RTD Resistance**, \$2010 **RTD Microvolts** and \$6114h **ADC Sampling Rate**. These objects are associated directly with the ADC chip used to measure the RTDs and source current voltages. As channels are disabled, object \$6114 is automatically updated by the controller to reflect approximately how many milliseconds will elapse between each scan of a particular channel. Objects \$2000 and \$2010 are available for debugging purposes.

Lastly, object \$5010 **ADC Filter Frequency** is a single value (non-array) that sets the rejection filter frequency used by the analog-to-digital converter. The only permissible values in this case are either 50Hz (i.e. Europe) or 60Hz (i.e. North America.)

1.3. Average Measurements

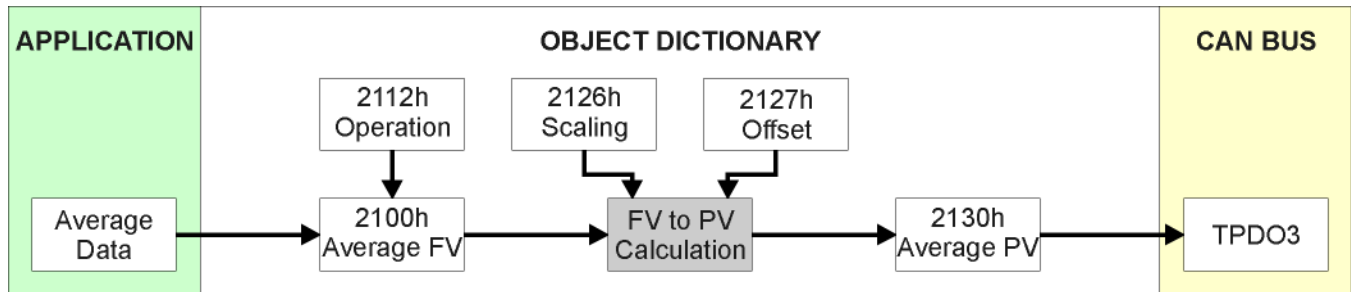

Figure 3 – Average Measurement Block Diagram

There are three types of average values that can be measured and broadcasted on a TPDO.

- a) Average of Bank 1 sensors (RTDs 1 to 4, active only)
- b) Average of Bank 2 sensors (RTDs 5 to 8, active only)
- c) Average of all sensors (active only)

Object \$2112 **Average Operating Mode** determines if the average value of any of the above will be enabled. When enabled by selecting “Normal Operation”, the average of all active channels is calculated and written to read-only object \$2100 **Average Input Field Value** in degrees Celsius. If a RTD channel is disabled, open or short circuited or ‘frozen’, then the value in the FV object is not counted in the average calculation.

As with the RTD inputs, the average FV can be converted to a process value using scaling objects \$2126 **Average Scaling Factor** and \$2127 **Average Scaling Offset**. The formula to convert to read-only object \$2130 **Average Input Process Value** is the same as describe in section 1.2.

By default, all averages are enabled and the calculated PVs are sent on TPDO3.

2. INSTALLATION INSTRUCTIONS

2.1. Dimensions and Pinout

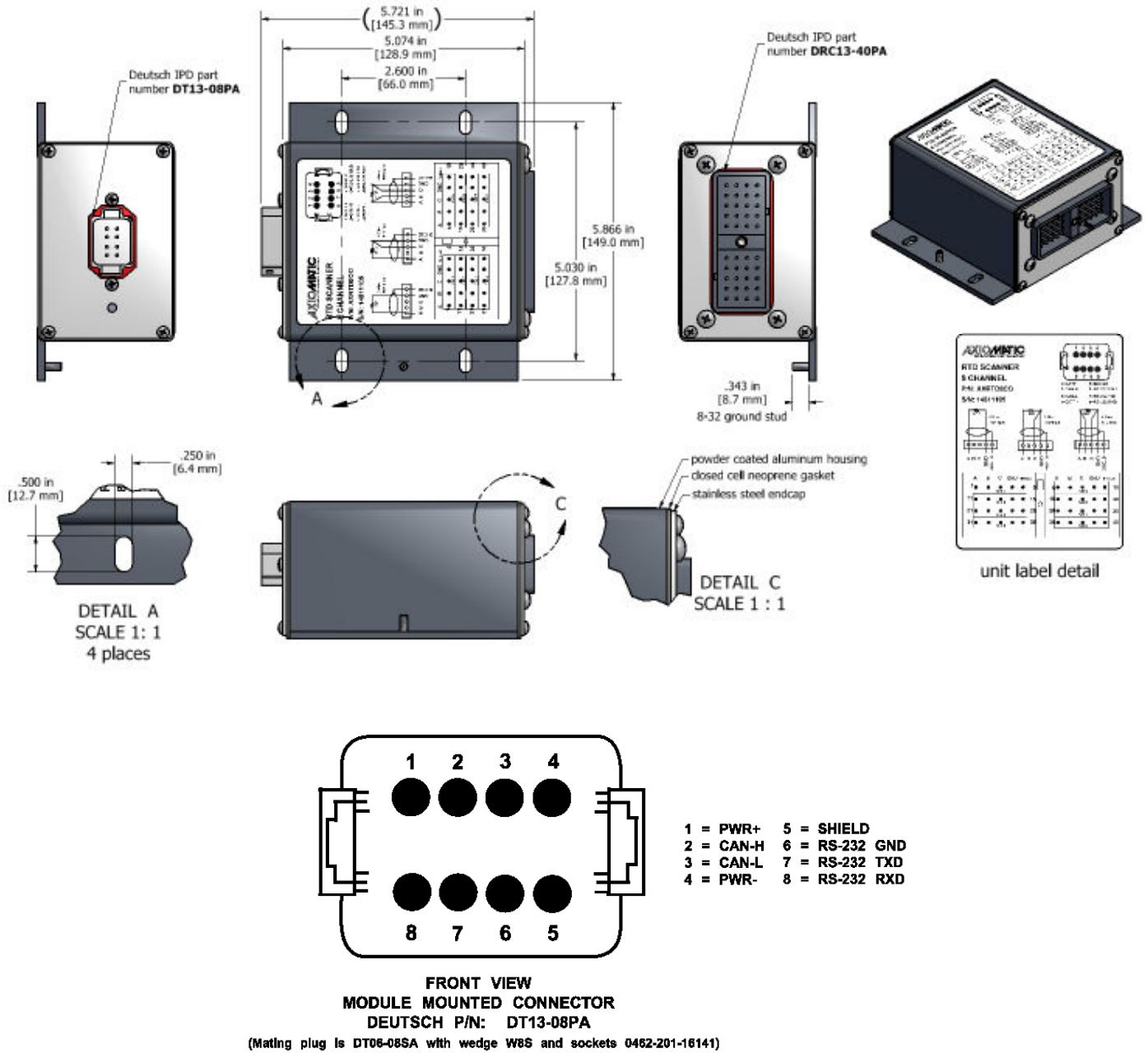

Typical Connections – RTD Module:

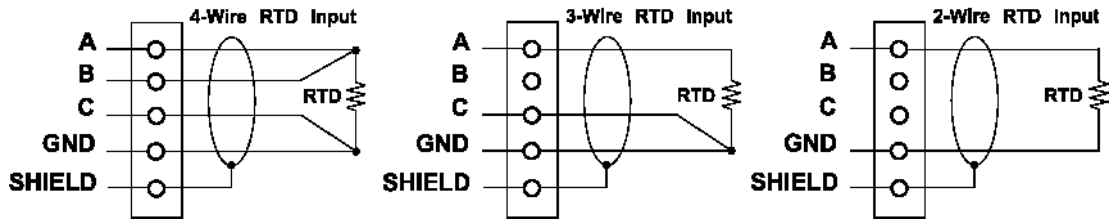

RTD MODULE - PIN OUT

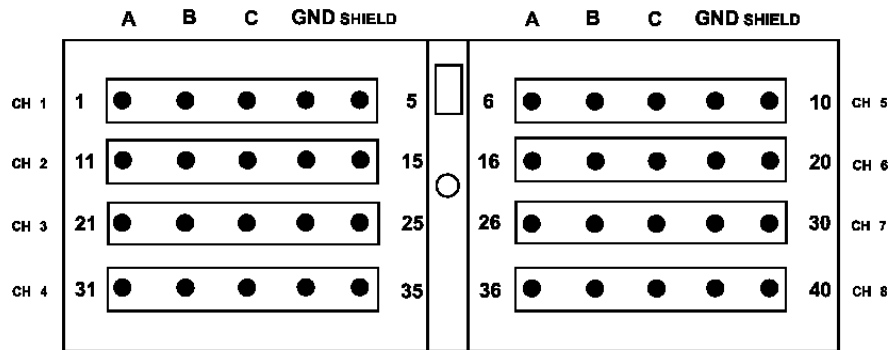

FRONT VIEW OF
MODULE MOUNTED CONNECTOR

Nov. 303 AJW

(Mating plug is Deutsch IPD p/n DRC16-40SA with sockets 0462-201-16141)

2.2. Installation Instructions

NOTES & WARNINGS

- Do not install near high-voltage or high-current devices.
- Ground the chassis for safety purposes and proper EMI shielding.
- Note the operating temperature range. All field wiring must be suitable for that temperature range.
- Install the unit with appropriate space available for servicing and for adequate wire harness access (15 cm) and strain relief (30 cm).
- Do not connect or disconnect the unit while the circuit is live, unless the area is known to be non-hazardous.

MOUNTING

The module is designed for mounting on the engine. If it is mounted without an enclosure, the RTD Scanner should be mounted vertically with connectors facing left and right to reduce likelihood of moisture entry.

The RTD wires and CAN communication cable are considered intrinsically safe. The power wires are not considered intrinsically safe.

Mask all labels if the unit is to be repainted, so label information remains visible.

Mounting ledges include holes sized for M6 or ¼ inch bolts. The bolt length will be determined by the end-user's mounting plate thickness. Typically 20 mm (3/4 inch) is adequate.

If the module is mounted off-engine, no wire or cable in the harness should exceed 30 meters in length. The power input wiring should be limited to 10 meters.

CONNECTIONS

Use the following Deutsch IPD mating plugs to connect to the integral receptacles. Wiring to these mating plugs must be in accordance with all applicable local codes. Suitable field wiring for the rated voltage and current must be used. The rating of the connecting cables must be at least 85°C. For ambient temperatures below -10°C and above +70°C, use field wiring suitable for both minimum and maximum ambient temperature.

Receptacle	Mating Socket (Refer to www.laddinc.com for more information on the wedgelock and contacts for this mating plug.)
Power and CAN bus: DT13-08PA	DT06-08SA
RTD Interface Receptacle: DRC13-40PA	DRC16-40SA DRC18-40SA

NOISE – ELECTRICAL CONNECTIONS

To reduce noise, separate all RTD wires from power wires. Shielded RTD wires will protect against ignition and injector noise.

GROUNDING

Protective Earth (PE) must be connected to the module's grounding lug to reduce the risk of electric shock. The conductor providing the connection must have a ring lug and wire larger than or equal to 4 mm² (12 AWG). The ring lug should be placed between the nut and a star washer.

All chassis grounding should go to a single ground point designated for the engine and all related equipment.

The ground strap that provides a low impedance path for EMI should be a ½ inch wide, flat, hollow braid, no more than 12 inches long with a suitable sized ring lug for the module's grounding lug. It may be used in place of the PE grounding conductor and would then perform both PE and EMI grounding functions.

SHIELDING

The RTD and CAN wiring should be shielded using a twisted conductor pair. All RTD wire shields should be terminated on the shield wire available on the 40-pin connector. The RTD wires should not be exposed for more than 50 mm (2 inches) without shielding. The shield may be cut off at the RTD end as it does not require termination at that end.

Shields can be AC grounded at one end and hard grounded at the opposite end to improve shielding effectiveness.

If the module is installed in a cabinet, shielded wiring can be terminated at the cabinet (earth ground), at the entry to the cabinet or at the RTD Scanner.

INPUT POWER

The main input to the power supply must be of low-impedance type for proper operation. If batteries are used, an alternator or other battery-charging device is necessary to maintain a stable supply voltage.

Central suppression of any surge events should be provided at the system level.

The installation of the equipment must include overcurrent protection between the power source and the RTD Scanner by means of a series connection of properly rated fuses or circuit breakers. Input power switches must be arranged external to the RTD Scanner.

The power input wiring should be limited to 10 meters.

Note the operating temperature range. All field wiring must be suitable for that temperature range.

RTD INPUT WIRING

Wiring for the RTD input must be shielded cable, 16 or 18 AWG. Cable lengths should be less than 30 meters. Shielding should be unbroken.

CAN WIRING

The CAN port is electrically isolated from all other circuits. The isolation is SELV rated with respect to product safety requirements. Refer to the CAN 2.0B specification for more information.

Shielded CAN cable is required. The RTD Scanner provides the CAN port shield connection ac coupled to chassis ground. The chassis ground stud located on the mounting foot must be tied directly to Earth Ground.

NETWORK CONSTRUCTION

Axiomatic recommends that multi-drop networks be constructed using a “daisy chain” or “backbone” configuration with short drop lines.

TERMINATION

It is necessary to terminate the network; therefore an external CAN termination is required. No more than two network terminators should be used on any one single network. A terminator is a 121Ω, 0.25 W, 1% metal film resistor placed between CAN_H and CAN_L terminals at the end two nodes on a network.

3. CANOPEN ® OBJECT DICTIONARY

The CANopen object dictionary of the RTD Scanner is based on CiA device profile DS-404 V1.2 (device profile for RTD Scanners). The object dictionary includes Communication Objects beyond the minimum requirements in the profile, as well as several manufacturer-specific objects for extended functionality.

3.1. NODE ID and BAUDRATE

By default, the RTD Scanner ships factory programmed with a Node ID = 127 (0x7F) and with Baudrate = 125 kbps.

3.1.1. LSS Protocol to Update

The only means by which the Node-ID and Baudrate can be changed is to use Layer Settling Services (LSS) and protocols as defined by CANopen ® standard DS-305.

Follow the steps below to configure either variable using LSS protocol. If required, please refer to the standard for more detailed information about how to use the protocol.

3.1.1.1. Setting Node-ID

- Set the module state to LSS-configuration by **sending** the following message:

<i>Item</i>	<i>Value</i>
COB-ID	0x7E5
Length	2
Data 0	0x04 (cs=4 for switch state global)
Data 1	0x01 (switches to configuration state)

- Set the Node-ID by **sending** the following message:

<i>Item</i>	<i>Value</i>
COB-ID	0x7E5
Length	2
Data 0	0x11 (cs=17 for configure node-id)
Data 1	Node-ID (set new Node-ID as a hexadecimal number)

- The module will send the following response (any other response is a failure):

<i>Item</i>	<i>Value</i>
COB-ID	0x7E4
Length	3
Data 0	0x11 (cs=17 for configure node-id)
Data 1	0x00
Data 2	0x00

- Save the configuration by **sending** the following message:

<i>Item</i>	<i>Value</i>
COB-ID	0x7E5
Length	1
Data 0	0x17 (cs=23 for store configuration)

- The module will send the following response (any other response is a failure):

<i>Item</i>	<i>Value</i>
COB-ID	0x7E4
Length	3
Data 0	0x17 (cs=23 for store configuration)
Data 1	0x00
Data 2	0x00

- Set the module state to LSS-operation by **sending** the following message:
(Note, the module will reset itself back to the pre-operational state)

<i>Item</i>	<i>Value</i>
COB-ID	0x7E5
Length	2
Data 0	0x04 (cs=4 for switch state global)
Data 1	0x00 (switches to waiting state)

3.1.1.2. Setting Baudrate

- Set the module state to LSS-configuration by **sending** the following message:

<i>Item</i>	<i>Value</i>
COB-ID	0x7E5
Length	2
Data 0	0x04 (cs=4 for switch state global)
Data 1	0x01 (switches to configuration state)

- Set the baudrate by **sending** the following message:

<i>Item</i>	<i>Value</i>
COB-ID	0x7E5
Length	3
Data 0	0x13 (cs=19 for configure bit timing parameters)
Data 1	0x00 (switches to waiting state)
Data 2	Index (select baudrate index per table 4)

Index	Bit Rate
0	1 Mbit/s
1	800 kbit/s
2	500 kbit/s
3	250 kbit/s
4	125 kbit/s (default)
5	reserved (100 kbit/s)
6	50 kbit/s
7	20 kbit/s
8	10 kbit/s

Table 2 – LSS Baudrate Indexes

- The module will send the following response (any other response is a failure):

Item	Value
COB-ID	0x7E4
Length	3
Data 0	0x13 (cs=19 for configure bit timing parameters)
Data 1	0x00
Data 2	0x00

- Activate bit timing parameters by **sending** the following message:

Item	Value
COB-ID	0x7E5
Length	3
Data 0	0x15 (cs=19 for activate bit timing parameters)
Data 1	<delay_lsb>
Data 2	<delay_msb>

The delay individually defines the duration of the two periods of time to wait until the bit timing parameters switch is done (first period) and before transmitting any CAN message with the new bit timing parameters after performing the switch (second period). The time unit of switch delay is 1 ms.

- Save the configuration by **sending** the following message (on the NEW baudrate):

Item	Value
COB-ID	0x7E5
Length	1
Data 0	0x17 (cs=23 for store configuration)

- The module will send the following response (any other response is a failure):

Item	Value
COB-ID	0x7E4
Length	3
Data 0	0x17 (cs=23 for store configuration)
Data 1	0x00
Data 2	0x00

- Set the module state to LSS-operation by **sending** the following message:
(Note, the module will reset itself back to the pre-operational state)

Item	Value
COB-ID	0x7E5
Length	2
Data 0	0x04 (cs=4 for switch state global)
Data 1	0x00 (switches to waiting state)

The following screen capture (left) shows the CAN data was sent (7E5h) and received (7E4h) by the tool when the baudrate was changed to 250 kbps using the LSS protocol. The other image (right) shows what was printed on the debug RS-232 menu while the operation took place.

Between CAN Frame 98 and 99, the baudrate on the CAN Scope tool was changed from 125 to 250 kbps.

The left screenshot shows the CAN Scope interface with the following data table:

Fram...	Absolute Time	RelTime	Id	Atr	L	d1	d2	d3	d4
95	11:42:45.248	6110	07E5		2	04	01		
96	11:42:54.468	9219	07E5		3	13	00	03	
97	11:42:54.468	0	07E4		3	13	00	00	
98	11:42:58.687	4218	07E5		3	15	88	13	
99	11:43:16.579	17891	07E5		1	17			
100	11:43:16.907	328	07E4		3	17	00	00	
101	11:43:23.017	6109	07E5		2	04	00		
102	11:43:23.017	0	0750		1	00			

The right screenshot shows the RS-232 debug menu output:

```

File Edit Setup Control Window Help
----- Main Menu -----
Choose one of the following:
U: View Object Dictionary
D: Default Object Dictionary
T: Toggle RS-232 Stream On/Off
S: Show/Stop Diagnostics
L: Load New Software
M: Main Menu (this)

->Node Id = 80
->Baudrate= 125 [kbps]
CO: PRE-OPERATIONAL
Activating new baud = 250 [kbps]
CO: STOP
Restarting CAN in 5000 [ms]
CO: PRE-OPERATIONAL
Storing ID
Storing Factory Parameters

Storing Baud
Storing Factory Parameters

Storing Communication Parameters

->Node Id = 80
->Baudrate= 250 [kbps]
CO: PRE-OPERATIONAL

```

3.2. COMMUNICATION OBJECTS (DS-301 and DS-404)

The communication objects supported by the RTD Scanner are listed in the following table. A more detailed description of some of the objects is given in the following subchapters. Only those objects that have device-profile specific information are described. For more information on the other objects, refer to the generic CANopen protocol specification DS-301.

<i>Index (hex)</i>	<i>Object</i>	<i>Object Type</i>	<i>Data Type</i>	<i>Access</i>	<i>PDO Mapping</i>
1000	Device Type	VAR	UNSIGNED32	RO	No
1001	Error Register	VAR	UNSIGNED8	RO	No
1002	Manufacturer Status Register	VAR	UNSIGNED32	RO	No
1003	Pre-Defined Error Field	ARRAY	UNSIGNED32	RO	No
100C	Guard Time	VAR	UNSIGNED16	RW	No
100D	Life Time Factor	VAR	UNSIGNED8	RW	No
1010	Store Parameters	ARRAY	UNSIGNED32	RW	No
1011	Restore Default Parameters	ARRAY	UNSIGNED32	RW	No
1016	Consumer Heartbeat Time	ARRAY	UNSIGNED32	RW	No
1017	Producer Heartbeat Time	VAR	UNSIGNED16	RW	No
1018	Identity Object	RECORD		RO	No
1020	Verify Configuration	ARRAY	UNSIGNED32	RW	No
1029	Error Behaviour	ARRAY	UNSIGNED8	RW	No
1400	RPDO1 Communication Parameter	RECORD		RW	No
1401	RPDO2 Communication Parameter	RECORD		RW	No
1402	RPDO3 Communication Parameter	RECORD		RW	No
1403	RPDO4 Communication Parameter	RECORD		RW	No
1600	RPDO1 Mapping Parameter	RECORD		RO	No
1601	RPDO2 Mapping Parameter	RECORD		RO	No
1602	RPDO3 Mapping Parameter	RECORD		RO	No
1603	RPDO4 Mapping Parameter	RECORD		RO	No
1800	TPDO1 Communication Parameter	RECORD		RW	No
1801	TPDO2 Communication Parameter	RECORD		RW	No
1802	TPDO3 Communication Parameter	RECORD		RW	No
1803	TPDO4 Communication Parameter	RECORD		RW	No
1A00	TPDO1 Mapping Parameter	RECORD		RW	No
1A01	TPDO2 Mapping Parameter	RECORD		RW	No
1A02	TPDO3 Mapping Parameter	RECORD		RW	No
1A03	TPDO4 Mapping Parameter	RECORD		RW	No

Per the CANopen ® standard DS-301, the following procedure shall be used for re-mapping, and is the same for both RPDOs and TPDOs.

- a) Destroy the PDO by setting bit **exists** (most significant bit) of sub-index 01h of the according PDO communication parameter to 1b
- b) Disable mapping by setting sub-index 00h of the corresponding mapping object to 0
- c) Modify the mapping by changing the values of the corresponding sub-indices
- d) Enable mapping by setting sub-index 00h to the number of mapped objects
- e) Create the PDO by setting bit **exists** (most significant bit) of sub-index 01h of the according PDO communication parameter to 0b

3.2.1. Object 1000h: Device Type

This object contains information about the device type as per device profile DS-404. The 32-bit parameter is divided into two 16-bit values, showing General and Additional information as shown below.

MSB	LSB
Additional Information = 0x1002	General Information = 0x0194 (404)

DS-404 defines the Additional Information field in the following manner:

- 0000h = reserved
- 0001h = digital input block
- 0002h = analog input block
- 0004h = digital output block
- 0008h = analog output block
- 0010h = controller block
- 0020h = alarm block
- 0040h ... 0800h = reserved
- 1000h ... 8000h = manufacturer-specific

The 0x10 in the MSB of the additional information indicates that this is the first CANopen ® RTD Scanner that has been manufactured by Axiomatic. The 0x02 in the LSB indicates that this module supports analog input blocks.

Object Description

Index	1000h
Name	Device Type
Object Type	VAR
Data Type	UNSIGNED32

Entry Description

Access	RO
PDO Mapping	No
Value Range	0x10020194
Default Value	0x10020194

3.2.2. Object 1001h: Error Register

This object is an error register for the device. Any time there is an error detected by the RTD Scanner, the Generic Error Bit (bit 0) is set. Only if there is no errors in the module will this bit will be cleared. No other bits in this register are used by the RTD Scanner.

Object Description

Index	1001h
Name	Error Register
Object Type	VAR
Data Type	UNSIGNED8

Entry Description

Access	RO
PDO Mapping	No
Value Range	00h or 01h
Default Value	0

3.2.3. Object 1002h: Manufacturer Status Register

This object is used for manufacturer debug purposes.

3.2.4. Object 1003h: Pre-Defined Error Field

This object provides an error history by listing the errors in the order that they have occurred. An error is added to the top of the list when it occurs, and is immediately removed when the error condition has been cleared. The latest error is always at sub-index 1, with sub-index 0 containing the number of errors currently in the list. When the device is in an error-free state, the value of sub-index 0 is zero.

The error list may be cleared by writing a zero to sub-index 0, which will clear all errors from the list, regardless of whether or not they are still present. Clearing the list does NOT mean that the module will return to the error-free behaviour state if at least one error is still active.

The RTD Scanner has a limitation of a maximum of 17 errors in the list. If the device registers more errors, the list will be truncated, and the oldest entries will be lost.

The error codes stored in the list are 32-bit unsigned numbers, consisting of two 16-bit fields. The lower 16-bit field is the EMCY error code, and the higher 16-bit field is a manufacturer-specific code. The manufacturer-specific code is divided into two 8-bit fields, with the higher byte indicating the error description, and the lower byte indicating the channel on which the error occurred.

MSB

LSB

Error Description	Channel-ID	EMCY Error Code
-------------------	------------	-----------------

If node-guarding is used (not recommended per the latest standard) and a lifeguard event occurs, the manufacturer-specific field will be set to 0x1000. On the other hand, if a heartbeat consumer fails to be received within the expected timeframe, the Error Description will be set to 0x80 and the Channel-ID (nn) will reflect the Node-ID of the consumer channel that was not producing. In this case, the manufacturer-specific field will therefore be 0x80nn. In both cases, the corresponding EMCY Error Code will be the Guard Error 0x8130.

When a sensor fault is detected (i.e. open or short circuit) then the Error Description will reflect what kind of error is present using the following table. In these cases, the corresponding EMCY Error Code that will be used is the Input Overload 0xF001.

When a system fault is detected using the threshold objects (\$4000, \$4010 or \$4020), then the Error Description will reflect which threshold was breached using the following table. In these cases, the corresponding EMCY Error Code that will be used is the Limit Exceed 0xF011.

In the unlikely event that a scanner fault is detected such as frozen data from the ADC chip or a math error occurred when calculating the temperature, then the Error Description will reflect the fault using the following table. In these cases, the corresponding EMCY Error Code that will be used is the Device Specific 0xFF00.

Flag	Meaning
0x02	Positive Overload, i.e. Open Circuit
0x04	Negative Overload, i.e. Short Circuit
0x10	Low Warning Threshold Exceeded
0x20	High Warning Threshold Exceeded
0x40	High Shutdown Threshold Exceeded
0x08	Math Error Occurred
0x80	Frozen Data Detected from ADC Chip

Table 3 – Error Descriptions

When a fault is detected, the corresponding Channel-ID will be 0x01 for RTD Input 1, 0x02 for RTD Input 2 ... to 0x08 for RTD Input 8.

The EMCY Error Codes supported by this module are reflected in Table 4 shown below.

Code	Meaning
0x0000	Error Reset (no errors)
0x8110	CAN Overrun
0x8130	Guard Error
0xF001	Input Overload – RTD Open or Short Circuit
0xF011	Limit Exceeded – See Table 3 above
0xFF00	Device Specific – See Table 3 above

Table 4 – EMCY Error Codes

Object Description

Index	1003h
Name	Pre-Defined Error Field
Object Type	ARRAY
Data Type	UNSIGNED32

Entry Description

Sub-Index	0h
Description	Number of entries
Access	RW
PDO Mapping	No
Value Range	0 to 17
Default Value	0

Sub-Index	1h to 17h
Description	Standard error field
Access	RO
PDO Mapping	No
Value Range	UNSIGNED32
Default Value	0

3.2.5. Object 100Ch: Guard Time

The objects at index 100Ch and 100Dh shall indicate the configured guard time respective to the life time factor. The life time factor multiplied with the guard time gives the life time for the life guarding protocol described in DS-301. The Guard Time value shall be given in multiples of ms, and a value of 0000h shall disable the life guarding.

It should be noted that this object, and that of 100Dh are only supported for backwards compatibility. The standard recommends that newer networks do not use the life guarding protocol, but rather heartbeat monitoring instead. Both life guarding and heartbeats can NOT be active simultaneously.

Object Description

Index	100Ch
Name	Guard Time
Object Type	VAR
Data Type	UNSIGNED16

Entry Description

Sub-Index	0h
Access	RW
PDO Mapping	No
Value Range	0 to 65535
Default Value	0

3.2.6. Object 100Dh: Lifetime Factor

The life time factor multiplied with the guard time gives the life time for the life guarding protocol. A value of 00h shall disable life guarding.

Object Description

Index	100Dh
Name	Life time factor
Object Type	VAR
Data Type	UNSIGNED8

Entry Description

Sub-Index	0h
Access	RW
PDO Mapping	No
Value Range	0 to 255
Default Value	0

3.2.7. Object 1010h: Store Parameters

This object supports the saving of parameters in non-volatile memory. In order to avoid storage of parameters by mistake, storage is only executed when a specific signature is written to the appropriate sub-index. The signature is “save”.

The signature is a 32-bit unsigned number, composed of the ASCII codes of the signature characters, according to the following table:

MSB		LSB	
e	v	a	s
65h	76h	61h	73h

On reception of the correct signature to an appropriate sub-index, the RTD Scanner will store the parameters in non-volatile memory, and then confirm the SDO transmission.

By read access, the object provides information about the module’s saving capabilities. For all sub-indexes, this value is 1h, indicating that the RTD Scanner saves parameters on command. **This means that if power is removed before the Store object is written, changes to the Object Dictionary will NOT have been saved in the non-volatile memory, and will be lost on the next power cycle.**

Object Description

Index	1010h
Name	Store Parameters
Object Type	ARRAY
Data Type	UNSIGNED32

Entry Description

Sub-Index	0h
Description	Largest sub-index supported
Access	RO
PDO Mapping	No
Value Range	4
Default Value	4

Sub-Index	1h
Description	Save all parameters
Access	RW
PDO Mapping	No
Value Range	0x65766173 (write access) 1h (read access)
Default Value	1h

Sub-Index	2h
Description	Save communication parameters
Access	RW
PDO Mapping	No
Value Range	0x65766173 (write access) 1h (read access)
Default Value	1h

Sub-Index	3h
Description	Save application parameters
Access	RW
PDO Mapping	No
Value Range	0x65766173 (write access) 1h (read access)
Default Value	1h

Sub-Index	4h
Description	Save manufacturer parameters
Access	RW
PDO Mapping	No
Value Range	0x65766173 (write access) 1h (read access)
Default Value	1h

3.2.8. Object 1011h: Restore Parameters

This object supports the restoring of the default values for the object dictionary in non-volatile memory. In order to avoid restoring of parameters by mistake, the device restores the defaults only when a specific signature is written to the appropriate sub-index. The signature is “load”.

The signature is a 32-bit unsigned number, composed of the ASCII codes of the signature characters, according to the following table:

MSB		LSB	
d	a	o	l
64h	61h	6Fh	6Ch

On reception of the correct signature to an appropriate sub-index, the RTD Scanner will restore the defaults in non-volatile memory, and then confirm the SDO transmission. **The default values are set valid only after the device is reset or power-cycled.** This means that the RTD Scanner will NOT start using the default values right away, but rather continue to run from whatever values were in the Object Dictionary prior to the restore operation.

By read access, the object provides information about the module’s default parameter restoring capabilities. For all sub-indexes, this value is 1h, indicating that the RTD Scanner restores defaults on command.

Object Description

Index	1011h
Name	Restore Default Parameters
Object Type	ARRAY
Data Type	UNSIGNED32

Entry Description

Sub-Index	0h
Description	Largest sub-index supported
Access	RO
PDO Mapping	No
Value Range	4
Default Value	4

Sub-Index	1h
Description	Restore all default parameters
Access	RW
PDO Mapping	No
Value Range	0x64616F6C (write access), 1h (read access)
Default Value	1h

Sub-Index	2h
Description	Restore default communication parameters
Access	RW
PDO Mapping	No
Value Range	0x64616F6C (write access), 1h (read access)
Default Value	1h

Sub-Index	3h
Description	Restore default application parameters
Access	RW
PDO Mapping	No
Value Range	0x64616F6C (write access), 1h (read access)
Default Value	1h

Sub-Index	4h
Description	Restore default manufacturer parameters
Access	RW
PDO Mapping	No
Value Range	0x64616F6C (write access), 1h (read access)
Default Value	1h

3.2.9. Object 1016h: Consumer Heartbeat Time

The RTD Scanner can be a consumer of heartbeat objects for up to four modules. This object defines the expected heartbeat cycle time for those modules, and if set to zero, it is not used. When non-zero, the time is a multiple of 1ms, and monitoring will start after the reception of the first heartbeat from the module. If the RTD Scanner fails to receive a heartbeat from a node in the expected timeframe, it will indicate a communication error, and respond as per object 1029h.

Bits	31-24	23-16	15-0
Value	Reserved 00h	Node-ID	Heartbeat time
Encoded as		UNSIGNED8	UNSIGNED16

Object Description

Index	1016h
Name	Consumer heartbeat time
Object Type	ARRAY
Data Type	UNSIGNED32

Entry Description

Sub-Index	0h
Description	Number of entries
Access	RO
PDO Mapping	No
Value Range	4
Default Value	4

Sub-Index	1h to 4h
Description	Consumer heartbeat time
Access	RW
PDO Mapping	No
Value Range	UNSIGNED32
Default Value	0

3.2.10. Object 1017h: Producer Heartbeat Time

The RTD Scanner could be configured to produce a cyclical heartbeat by writing a non-zero value to this object. The value will be given in multiples of 1ms, and a value of 0 shall disable the heartbeat.

Object Description

Index	1017h
Name	Producer heartbeat time
Object Type	VAR
Data Type	UNSIGNED16

Entry Description

Sub-Index	0h
Access	RW
PDO Mapping	No
Value Range	10 to 65535
Default Value	0

3.2.11. Object 1018h: Identity Object

The identity object indicates the data of the RTD Scanner, including vendor id, device id, software and hardware version numbers, and the serial number.

In the Revision Number entry at sub-index 3, the format of the data is as shown below

MSB	LSB
Major revision number (object dictionary)	Hardware Revision Software Version

Object Description

Index	1018h
Name	Identity Object
Object Type	RECORD
Data Type	Identity Record

Entry Description

Sub-Index	0h
Description	Number of entries
Access	RO
PDO Mapping	No
Value Range	4
Default Value	4

Sub-Index	1h
Description	Vendor ID
Access	RO
PDO Mapping	No
Value Range	0x00000055
Default Value	0x00000055 (Axiomatic)

Sub-Index	2h
Description	Product Code
Access	RO
PDO Mapping	No
Value Range	0x00010106
Default Value	0x00010106

Sub-Index	3h
Description	Revision Number
Access	RO
PDO Mapping	No
Value Range	UNSIGNED32
Default Value	No

Sub-Index	4h
Description	Serial Number
Access	RO
PDO Mapping	No
Value Range	UNSIGNED32
Default Value	No

3.2.12. Object 1020h: Verify Configuration

This object can be read to see what date the software (version identified in object 1018h) was compiled. The date is represented as a hexadecimal value showing day/month/year as per the format below. The time value at sub-index 2 is a hexadecimal value showing the time in a 24 hour clock

MSB		LSB
Day (in 1-Byte Hex)	Month (in 1-Byte Hex)	Year (in 2-Byte Hex)
00	00	Time (in 2-Byte Hex)

For example, a value of 0x10082010 would indicate that the software was compiled on August 10th, 2010. A time value of 0x00001620 would indicate it was compiled at 4:20pm.

Object Description

Index	1020h
Name	Verify configuration
Object Type	ARRAY
Data Type	UNSIGNED32

Entry Description

Sub-Index	0h
Description	Number of entries
Access	RO
PDO Mapping	No
Value Range	2
Default Value	2

Sub-Index	1h
Description	Configuration date
Access	RO
PDO Mapping	No
Value Range	UNSIGNED32
Default Value	No

Sub-Index	2h
Description	Configuration time
Access	RO
PDO Mapping	No
Value Range	UNSIGNED32
Default Value	No

3.2.13. Object 1029h: Error Behaviour

This object controls the state that the RTD Scanner will be set into in case of an error of the type associated with the sub-index.

Communication errors are anything associate with the CAN network including life guard or heartbeat events, buffer overruns, busoff, etc.

Sensor errors are those associated with the sensor itself such as an open or short circuit.

System errors are those associate with the fault detection thresholds set by the used in objects \$4010, \$4020 and \$4030.

Scanner errors are those associate with the performance of the device itself, such as detecting frozen data from the ADC chip, or returning a math error when converting resistance to temperature

Object Description

Index	1029h
Name	Error Behaviour
Object Type	ARRAY
Data Type	UNSIGNED8

Entry Description

Sub-Index	0h
Description	Number of entries
Access	RO
PDO Mapping	No
Value Range	2
Default Value	2

Sub-Index	1h
Description	Communication Error
Access	RW
PDO Mapping	No
Value Range	0 = Pre-Operational 1 = No State Change 2 = Stopped
Default Value	0 (Pre-Operational)

Sub-Index	2h
Description	Sensor Error
Access	RW
PDO Mapping	No
Value Range	0 = Pre-Operational 1 = No State Change 2 = Stopped
Default Value	1 (No State Change)

Sub-Index	3h
Description	System Error
Access	RW
PDO Mapping	No
Value Range	0 = Pre-Operational 1 = No State Change 2 = Stopped
Default Value	1 (No State Change)

Sub-Index	4h
Description	Scanner Error
Access	RW
PDO Mapping	No
Value Range	0 = Pre-Operational 1 = No State Change 2 = Stopped
Default Value	0 (Pre-Operational)

3.2.14. RPDO Behaviour

The RTD Scanner can support up to four RPDO messages, but in reality, it does not use them. The other RPDO objects are provided simply for compliance with the standard CANopen® Object Dictionary, but are disabled on this module (mapping objects are read-only)

All RPDOs on the RTD Scanner use the same default communication parameters, with the PDO IDs set according to the pre-defined connection set described in DS-301. All RPDOs do not exist, there is no RTR allowed, they use 11-bit CAN-IDs (base frame valid) and are event-driven.

Object Description

Index	1400h to 1403h
Name	RPDO communication parameter
Object Type	RECORD
Data Type	PDO Communication Record

Entry Description

Sub-Index	0h
Description	Number of entries
Access	RO
PDO Mapping	No
Value Range	5
Default Value	5

Sub-Index	1h
Description	COB-ID used by RPDO
Access	RW
PDO Mapping	No
Value Range	See value definition in DS-301
Default Value	C0000000h + RPDOx + Node-ID

X	RPDOx ID
1	0200h
2	0300h
3	0400h
4	0500h

Node-ID = Node-ID of the module.

C0000000h in the COB-ID indicates that the PDO does not exist and no RTR is allowed

Sub-Index	2h
Description	Transmission type
Access	RO
PDO Mapping	No
Value Range	See value definition in DS-301
Default Value	255 (FFh) = Event Driven

Sub-Index	3h
Description	Inhibit Time
Access	RW
PDO Mapping	No
Value Range	See value definition in DS-301
Default Value	0

Sub-Index	4h
Description	Compatibility entry
Access	RW
PDO Mapping	No
Value Range	UNSIGNED8
Default Value	0

Sub-Index	5
Description	Event-timer
Access	RW
PDO Mapping	No
Value Range	See value definition in DS-301
Default Value	0

3.2.15. TPDO Behaviour

The RTD Scanner can support up to four TPDO messages, and all are enabled by default.

TPDO1 Mapping at Object 1A00h: Default ID 0x180 + Node ID

Sub-Index	Value	Object
0	4	Number of mapped application objects in PDO
1	0x71300110	RTD Input 1 Process Value
2	0x71300210	RTD Input 2 Process Value
3	0x71300310	RTD Input 3 Process Value
4	0x71300410	RTD Input 4 Process Value

TPDO2 Mapping at Object 1A01h: Default ID 0x280 + Node ID

Sub-Index	Value	Object
0	4	Number of mapped application objects in PDO
1	0x71300510	RTD Input 5 Process Value
2	0x71300610	RTD Input 6 Process Value
3	0x71300710	RTD Input 7 Process Value
4	0x71300810	RTD Input 8 Process Value

TPDO3 Mapping at Object 1A02h: Default ID 0x380 + Node ID

Sub-Index	Value	Object
0	3	Number of mapped application objects in PDO
1	0x21300110	Average Value of Bank 1 RTDs (1 to 4)
2	0x21300210	Average Value of Bank 2 RTDs (5 to 8)
3	0x21300310	Average Value of All RTDs
4	0	Not used by default

TPDO4 Mapping at Object 1A03h: Default ID 0x480 + Node ID

Sub-Index	Value	Object
0	2	Number of mapped application objects in PDO
3	0x50000020	Power Supply Measured
3	0x50010020	Current Source Measured
3	0	Not used by default
4	0	Not used by default

(Note: This TPDO is not transmitted by default, as the event-timer in object \$1803 is set to 0)

All TPDOs on the RTD Scanner use the same default communication parameters, with the PDO IDs set according to the pre-defined connection set described in DS-301. All TPDOs are event-driven, there is no RTR allowed, and they use 11-bit CAN-IDs (base frame valid).

Object Description

Index	1800h to 1807h
Name	TPDO communication parameter
Object Type	RECORD
Data Type	PDO Communication Record

Entry Description

Sub-Index	0h
Description	Number of entries
Access	RO
PDO Mapping	No
Value Range	5
Default Value	5

Sub-Index	1h
Description	COB-ID used by TPDO
Access	RW
PDO Mapping	No
Value Range	See value definition in DS-301
Default Value	40000000h + TPDOx + Node-ID

X	TPDOx ID
1	0180h
2	0280h
3	0380h
4	0480h

Node-ID = Node-ID of the module. The TPDO COB-IDs are automatically updated if the Node-ID is changed by LSS protocol.

80000000h in the COB-ID would indicate that the PDO does not exist (destroyed)

40000000h in the COB-ID indicates that there is no RTR allowed on the PDO

Sub-Index	2h
Description	Transmission type
Access	RO
PDO Mapping	No
Value Range	See value definition in DS-301
Default Value	254 (FEh) = Event Driven

Sub-Index	3h
Description	Inhibit Time
Access	RW
PDO Mapping	No
Value Range	See value definition in DS-301
Default Value	0

Sub-Index	4h
Description	Compatibility entry
Access	RW
PDO Mapping	No
Value Range	UNSIGNED8
Default Value	0

Sub-Index	5
Description	Event-timer
Access	RW
PDO Mapping	No
Value Range	See value definition in DS-301
Default Value	1000ms (on objects 1800h to 1802h) 0ms (on object 1803h)

3.3. APPLICATION OBJECTS (DS-404)

Index (hex)	Object	Object Type	Data Type	Access	PDO Mapping
6100	RTD Input Field Value	ARRAY	FLOAT32	RO	Yes
6110	RTD Sensor Type	ARRAY	UNSIGNED16	RW	No
6112	RTD Operating Mode	ARRAY	UNSIGNED8	RW	No
6114	ADC Sampling Rate	ARRAY	UNSIGNED32	RO	No
6126	RTD Scaling Factor	ARRAY	FLOAT32	RW	No
6127	RTD Scaling Offset	ARRAY	FLOAT32	RW	No
7130	RTD Input Process Value	ARRAY	INTEGER16	RO	Yes
6150	RTD Status	ARRAY	UNSIGNED8	RO	Yes

3.3.1. Object 6100h: RTD Input Field Value

This read-only object represents the measured temperature of the associated RTD input in Degrees Celsius. When the corresponding sub-index in object \$2000 is set to TRUE, the calculated temperature is automatically adjusted for the cold junction temperature compensation.

Object Description

Index	6100h
Name	RTD Input Field Value
Object Type	ARRAY
Data Type	FLOAT32

Entry Description

Sub-Index	0h
Description	Largest sub-index supported
Access	RO
PDO Mapping	No
Value Range	8
Default Value	8

Sub-Index	1h to 8h (X = 1 to 8)
Description	RTD Input X Temperature
Access	RO
PDO Mapping	Yes
Value Range	-273°C to 1735°C
Default Value	No

3.3.2. Object 6110h: RTD Sensor Type

This object determines what kind of RTD is connected to the input. The formulas used to calculate the resistance of the sensor based on the voltage readings taken on the various input pins are shown in Figure 1. The following sensor types are supported by the scanner.

Value	Meaning
10000	Two wire sensor
10001	Three wire sensor
10002	Four wire sensor

Table 5 – Supported RTD Types

Object Description

Index	6110h
Name	RTD Sensor Type
Object Type	ARRAY
Data Type	UNSIGNED16

Entry Description

Sub-Index	0h
Description	Largest sub-index supported
Access	RO
PDO Mapping	No
Value Range	8
Default Value	8

Sub-Index	1h to 8h (X = 1 to 8)
Description	RTD X Sensor Type
Access	RW
PDO Mapping	No
Value Range	See Table 5
Default Value	10001 (3-wire)

3.3.3. Object 6112h: RTD Operating Mode

This object establishes whether a RTD input is active. When a sub-index is set to zero (0) “Channel off,” the associate input is disabled. As described in section 1.2, the FV for the input is loaded with 0xFFFFFFFF (not a number) and the PV with 0xFFFF (-1). All error flags associated with the channel are cleared. This channel is also ignored in any averaging.

By default, all eight channels have this object set to one (1) “Normal Operation.”

Object Description

Index	6112h
Name	RTD Operating Mode
Object Type	ARRAY
Data Type	UNSIGNED8

Entry Description

Sub-Index	0h
Description	Largest sub-index supported
Access	RO
PDO Mapping	No
Value Range	8
Default Value	8

Sub-Index	1h to 8h (X = 1 to 8)
Description	RTD X Operating Mode
Access	RW
PDO Mapping	No
Value Range	0 or 1
Default Value	1 (Normal Operation)

3.3.4. Object 6114h: ADC Sample Rate

This read-only object is automatically updated when an input channel is disabled by object \$6112. When read, it reflects the approximate time between scan updates for any given channel, in milliseconds.

Object Description

Index	6114h
Name	ADC Sample Rate
Object Type	ARRAY
Data Type	UNSIGNED32

Entry Description

Sub-Index	0h
Description	Largest sub-index supported
Access	RO
PDO Mapping	No
Value Range	8
Default Value	8

Sub-Index	1h to 8h (X = 1 to 8)
Description	RTD X Sample Rate
Access	RO
PDO Mapping	No
Value Range	100ms to 900ms
Default Value	900ms

3.3.5. Object 6126h: RTD Scaling Factor

This object represents the scaling factor by which the RTD field value is multiplied to get the process value.

Object Description

Index	6126h
Name	RTD Scaling Factor
Object Type	ARRAY
Data Type	FLOAT32

Entry Description

Sub-Index	0h
Description	Largest sub-index supported
Access	RO
PDO Mapping	No
Value Range	8
Default Value	8

Sub-Index	1h to 8h (X = 1 to 8)
Description	RTD X Scaling Factor
Access	RW
PDO Mapping	No
Value Range	-1000.0 to 1000.0
Default Value	16.0 [0.0625°C/bit]

3.3.6. Object 6127h: RTD Scaling Offset

This object represents the scaling offset which is added to the scaled RTD field value to get the process value.

$$\text{Process Value} = (\text{Field Value} * \text{Scaling Factor}) + \text{Scaling Offset}$$

Object Description

Index	6127h
Name	RTD Scaling Offset
Object Type	ARRAY
Data Type	FLOAT32

Entry Description

Sub-Index	0h
Description	Largest sub-index supported
Access	RO
PDO Mapping	No
Value Range	8
Default Value	8

Sub-Index	1h to 8h (X = 1 to 8)
Description	RTD X Scaling Offset
Access	RW
PDO Mapping	No
Value Range	-10000.0 to 10000.0
Default Value	4368.0 (-273°C * 16)

3.3.7. Object 7130h: RTD Input Process Value

This read-only object represents the scaled value of the measured RTD temperature.

Object Description

Index	7130h
Name	RTD Input Process Value
Object Type	ARRAY
Data Type	INTEGER16

Entry Description

Sub-Index	0h
Description	Largest sub-index supported
Access	RO
PDO Mapping	No
Value Range	8
Default Value	8

Sub-Index	1h to 8h (X = 1 to 8)
Description	RTD X Process Value
Access	RO
PDO Mapping	Yes
Value Range	-32768 to 32767
Default Value	No

3.3.8. Object 6150h: RTD Status

This read-only object reflects the status of the associated RTD input field value. When set to zero, it indicates that the data measured is within normal operating limits. When the least significant bit in the byte is set to 1, it indicates that the data is outside of the normal operating range. Other bits in the byte are set as per the following bit combinations.

Frozen Data	High Shutdown	High Warn	Low Warn	Math Error	Negative Overload	Positive Overload	Data Not Valid
7	6	5	4	3	2	1	0

Value	Meaning
00h	Data Valid and within normal operating range
03h	Positive Overload, i.e. Open Circuit
05h	Negative Overload, i.e. Short Circuit
09h	Math Error, Data not valid
10h	Data Valid, but outside of normal range, low warning
20h	Data Valid, but outside of normal range, high warning
41h	Data too high, shutdown
81h	ADC not responding, 'frozen' data

Table 6 – RTD Status Values

Object Description

Index	6150h
Name	RTD Status
Object Type	ARRAY
Data Type	UNSIGNED8

Entry Description

Sub-Index	0h
Description	Largest sub-index supported
Access	RO
PDO Mapping	No
Value Range	8
Default Value	8

Sub-Index	1h to 8h (X = 1 to 8)
Description	RTD X Status
Access	RO
PDO Mapping	Yes
Value Range	See Table 6
Default Value	0 (Data Valid)

3.4. MANUFACTURER OBJECTS

Index (hex)	Object	Object Type	Data Type	Access	PDO Mapping
2000	RTD Resistance	ARRAY	FLOAT32	RO	No
2010	RTD Microvolts	ARRAY	INTEGER32	RO	No
2100	Average Input Field Value	ARRAY	FLOAT32	RO	Yes
2112	Average Operating Mode	ARRAY	UNSIGNED8	RW	No
2126	Average Scaling Factor	ARRAY	FLOAT32	RW	No
2127	Average Scaling Offset	ARRAY	FLOAT32	RW	No
2130	Average Input Process Value	ARRAY	INTEGER16	RO	Yes
3000	RTD Coefficient	ARRAY	UNSIGNED16	RW	No
3010	Callendar-Van Dusen Constant A	ARRAY	FLOAT32	RW	No
3020	Callendar-Van Dusen Constant B	ARRAY	FLOAT32	RW	No
3030	Callendar-Van Dusen Constant C	ARRAY	FLOAT32	RW	No
4000	Low Temperature Warning Threshold	ARRAY	INTEGER16	RW	No
4010	High Temperature Warning Threshold	ARRAY	INTEGER16	RW	No
4020	High Temperature Shutdown Threshold	ARRAY	INTEGER16	RW	No
4030	Error React Delay	ARRAY	UNSIGNED16	RW	No
5000	Power Supply Measured	VAR	FLOAT32	RO	Yes
5001	Current Source Measured	VAR	FLOAT32	RO	Yes
5010	ADC Filter Frequency	VAR	UNSIGNED8	RW	No
5555	Start in Operational Mode	VAR	BOOLEAN	RW	No

3.4.1. Object 2000h: RTD Resistance

This read-only object is available for diagnostic purposes. It reflects the measured resistance of the sensor input .

Object Description

Index	2000h
Name	RTD Resistance
Object Type	ARRAY
Data Type	FLOAT32

Entry Description

Sub-Index	0h
Description	Largest sub-index supported
Access	RO
PDO Mapping	No
Value Range	8
Default Value	8

Sub-Index	1h to 8h (X = 1 to 8)
Description	RTD X Resistance Measured
Access	RO
PDO Mapping	No
Value Range	Dependent on Sensor Type
Default Value	No

3.4.2. Object 2010h: RTD Microvolts

This read-only object is available for diagnostic purposes. It reflects the raw microvolt reading measured by the ADC chip directly.

Object Description

Index	2010h
Name	RTD Microvolts
Object Type	ARRAY
Data Type	INTEGER32

Entry Description

Sub-Index	0h
Description	Largest sub-index supported
Access	RO
PDO Mapping	No
Value Range	8
Default Value	8

Sub-Index	1h to 8h (X = 1 to 8)
Description	RTD X Microvolt Reading
Access	RO
PDO Mapping	No
Value Range	Dependent on Sensor Type
Default Value	No

3.4.3. Object 2100h: Average Input Field Value

This read-only object reflects the calculated average of a given subset of RTD inputs. Channels with invalid input data (i.e. disabled, open/short circuited or frozen) are not used in the average calculations. The average input field values are calculated by adding the temperature of all valid channels, then dividing by the number of valid inputs.

Object Description

Index	2100h
Name	Average Input Field Value
Object Type	ARRAY
Data Type	FLOAT32

Entry Description

Sub-Index	0h
Description	Largest sub-index supported
Access	RO
PDO Mapping	No
Value Range	3
Default Value	3

Sub-Index	1h
Description	Bank 1 Average FV (RTD1 to RTD4)
Access	RO
PDO Mapping	Yes
Value Range	-273°C to 1735°C
Default Value	No

Sub-Index	2h
Description	Bank 2 Average FV (RTD5 to RTD8)
Access	RO
PDO Mapping	Yes
Value Range	-273°C to 1735°C
Default Value	No

Sub-Index	3h
Description	Total Average FV
Access	RO
PDO Mapping	Yes
Value Range	-273°C to 1735°C
Default Value	No

3.4.4. Object 2112h: Average Operating Mode

This object determines if the averaging calculation is performed for the given sub-index. When set to one (1) “Normal Operation”, averaging is performed. When set to zero (0) “Channel off”, the average for the bank(s) is not available.

Object Description

Index	2112h
Name	Average Operating Mode
Object Type	ARRAY
Data Type	UNSIGNED8

Entry Description

Sub-Index	0h
Description	Largest sub-index supported
Access	RO
PDO Mapping	No
Value Range	3
Default Value	3

Sub-Index	1h
Description	Bank 1 Average Operation
Access	RW
PDO Mapping	No
Value Range	0 or 1
Default Value	1 (TRUE)

Sub-Index	2h
Description	Bank 2 Average Operation
Access	RW
PDO Mapping	No
Value Range	0 or 1
Default Value	1 (TRUE)

Sub-Index	3h
Description	Total Average Operation
Access	RW
PDO Mapping	No
Value Range	0 or 1
Default Value	1 (TRUE)

3.4.5. Object 2126h: Average Scaling Factor

This object represents the scaling factor by which the average field value is multiplied to get the process value.

Object Description

Index	2126h
Name	Average Scaling Factor
Object Type	ARRAY
Data Type	FLOAT32

Entry Description

Sub-Index	0h
Description	Largest sub-index supported
Access	RO
PDO Mapping	No
Value Range	3
Default Value	3

Sub-Index	1h
Description	Bank 1 Average Scaling Factor
Access	RW
PDO Mapping	No
Value Range	-1000.0 to 1000.0
Default Value	16.0 [0.0625°C/bit]

Sub-Index	2h
Description	Bank 2 Average Scaling Factor
Access	RW
PDO Mapping	No
Value Range	-1000.0 to 1000.0
Default Value	16.0 [0.0625°C/bit]

Sub-Index	3h
Description	Total Average Scaling Factor
Access	RW
PDO Mapping	No
Value Range	-1000.0 to 1000.0
Default Value	16.0 [0.0625°C/bit]

3.4.6. Object 2126h: Average Scaling Offset

This object represents the scaling offset which is added to the scaled average field value to get the process value.

$$\text{Process Value} = (\text{Field Value} * \text{Scaling Factor}) + \text{Scaling Offset}$$

Object Description

Index	2127h
Name	Average Scaling Offset
Object Type	ARRAY
Data Type	FLOAT32

Entry Description

Sub-Index	0h
Description	Largest sub-index supported
Access	RO
PDO Mapping	No
Value Range	3
Default Value	3

Sub-Index	1h
Description	Bank 1 Average Scaling Offset
Access	RW
PDO Mapping	No
Value Range	-10000.0 to 10000.0
Default Value	4368.0 (-273°C * 16)

Sub-Index	2h
Description	Bank 2 Average Scaling Offset
Access	RW
PDO Mapping	No
Value Range	-10000.0 to 10000.0
Default Value	4368.0 (-273°C * 16)

Sub-Index	3h
Description	Total Average Scaling Offset
Access	RW
PDO Mapping	No
Value Range	-10000.0 to 10000.0
Default Value	4368.0 (-273°C * 16)

3.4.7. Object 2130h: Average Input Process Value

This read-only object represents the scaled value of the measured average temperature.

Object Description

Index	2130h
Name	Average Input Process Value
Object Type	ARRAY
Data Type	FLOAT32

Entry Description

Sub-Index	0h
Description	Largest sub-index supported
Access	RO
PDO Mapping	No
Value Range	3
Default Value	3

Sub-Index	1h
Description	Bank 1 Average PV (RTD1 to RTD4)
Access	RO
PDO Mapping	Yes
Value Range	-32768 to 32767
Default Value	No

Sub-Index	2h
Description	Bank 2 Average PV (RTD5 to RTD8)
Access	RO
PDO Mapping	Yes
Value Range	-32768 to 32767
Default Value	No

Sub-Index	3h
Description	Total Average PV
Access	RO
PDO Mapping	Yes
Value Range	-32768 to 32767
Default Value	No

3.4.8. Object 3000h: RTD Coefficient

This object determines the Callendar-Van Dusen constants that will be used in the resistance to temperature calculation. See Table 1 in section 1.2 for the relationship between the supported RTD Coefficients, and the Callendar-Van Dusen constants that are used. Whenever this object is written with a non-zero value, the data in objects \$3010, \$3020 and \$3030 are automatically updated per Table 1.

Value	Meaning
0	USER DEFINED
1	IEC 00385
2	JIS 003916
3	US 003902
4	Legacy US 003920
5	SAMA 003923

Table 7 - Supported RTD Coefficients

Object Description

Index	3000h
Name	RTD Coefficient
Object Type	ARRAY
Data Type	UNSIGNED16

Entry Description

Sub-Index	0h
Description	Largest sub-index supported
Access	RO
PDO Mapping	No
Value Range	8
Default Value	8

Sub-Index	1h to 8h (X = 1 to 8)
Description	RTD X Coefficient
Access	RW
PDO Mapping	No
Value Range	See Table 7
Default Value	1 (IEC 00385)

3.4.9. Object 3010h: Callendar-Van Dusen Constant A

This object is used in the resistance to temperature conversion function per the following relationship. The data in this object is multiplied by 10^{-3} such that it will represent the variable A in the formula.

$$R_t = R_0[1 + At + Bt^2 + C(t-100)t^3] \text{ in which } C \text{ is only applicable when } t < 0 \text{ } ^\circ\text{C}.$$

When the RTD coefficient selected in object \$3000 is a non-zero value (i.e. not user defined), this object is treated as a read-only parameter. When object \$3000 changes, this object is automatically updated to the appropriate value as shown in column 2 of Table 1.

Object Description

Index	3010h
Name	Callendar-Van Dusen Constant A
Object Type	ARRAY
Data Type	FLOAT32

Entry Description

Sub-Index	0h
Description	Largest sub-index supported
Access	RO
PDO Mapping	No
Value Range	8
Default Value	8

Sub-Index	1h to 8h (X = 1 to 8)
Description	RTD X Callendar-Van Dusen A
Access	RW (only when corresponding sub-index in object 3000 is zero)
PDO Mapping	No
Value Range	-9.9 to 9.9
Default Value	3.90830

3.4.10. Object 3020h: Callendar-Van Dusen Constant B

This object is used in the resistance to temperature conversion function per the following relationship. The data in this object is multiplied by 10^{-7} such that it will represent the variable B in the formula.

$$R_t = R_0[1 + At + Bt^2 + C(t-100)t^3] \text{ in which C is only applicable when } t < 0 \text{ } ^\circ\text{C}.$$

When the RTD coefficient selected in object \$3000 is a non-zero value (i.e. not user defined), this object is treated as a read-only parameter. When object \$3000 changes, this object is automatically updated to the appropriate value as shown in column 3 of Table 1.

Object Description

Index	3020h
Name	Callendar-Van Dusen Constant B
Object Type	ARRAY
Data Type	FLOAT32

Entry Description

Sub-Index	0h
Description	Largest sub-index supported
Access	RO
PDO Mapping	No
Value Range	8
Default Value	8

Sub-Index	1h to 8h (X = 1 to 8)
Description	RTD X Callendar-Van Dusen B
Access	RW (only when corresponding sub-index in object 3000 is zero)
PDO Mapping	No
Value Range	-9.9 to 9.9
Default Value	-5.77500

3.4.11. Object 3030h: Callendar-Van Dusen Constant C

This object is used in the resistance to temperature conversion function per the following relationship. The data in this object is multiplied by 10^{-12} such that it will represent the variable C in the formula.

$$R_t = R_0[1 + At + Bt^2 + C(t-100)t^3] \text{ in which C is only applicable when } t < 0 \text{ } ^\circ\text{C.}$$

When the RTD coefficient selected in object \$3000 is a non-zero value (i.e. not user defined), this object is treated as a read-only parameter. When object \$3000 changes, this object is automatically updated to the appropriate value as shown in column 4 of Table 1.

Object Description

Index	3030h
Name	Callendar-Van Dusen Constant B
Object Type	ARRAY
Data Type	FLOAT32

Entry Description

Sub-Index	0h
Description	Largest sub-index supported
Access	RO
PDO Mapping	No
Value Range	8
Default Value	8

Sub-Index	1h to 8h (X = 1 to 8)
Description	RTD X Callendar-Van Dusen C
Access	RW (only when corresponding sub-index in object 3000 is zero)
PDO Mapping	No
Value Range	-9.9 to 9.9
Default Value	-4.18301

3.4.12. Object 4000h: Low Temperature Warning Threshold

This object sets the low threshold of the normal operating temperature range for each RTD's input field value (\$6100.) Any FV value below this limit flags a low warning in the corresponding RTD's status byte (\$6150), as well as setting an EMCY code in the pre-defined error field (\$1003). The data in sub-indexes 1 to 8 is interpreted with a fixed resolution of 0.1°C/bit.

Object Description

Index	4000h
Name	Low Temperature Warning Threshold
Object Type	ARRAY
Data Type	INTEGER16

Entry Description

Sub-Index	0h
Description	Largest sub-index supported
Access	RO
PDO Mapping	No
Value Range	8
Default Value	8

Sub-Index	1h to 8h (X = 1 to 8)
Description	RTD X Low Warning Temp.
Access	RW
PDO Mapping	No
Value Range	-2730 to (RTD X High Warning Temp – 100)
Default Value	-200 [-20°C]

3.4.13. Object 4010h: High Temperature Warning Threshold

This object sets the high threshold of the normal operating temperature range for each RTD's input field value (\$6100.) Any FV value above this limit flags a high warning in the corresponding RTD's status byte (\$6150), as well as setting an EMCY code in the pre-defined error field (\$1003). The data in sub-indexes 1 to 8 is interpreted with a fixed resolution of 0.1°C/bit.

Object Description

Index	4010h
Name	High Temperature Warning Threshold
Object Type	ARRAY
Data Type	INTEGER16

Entry Description

Sub-Index	0h
Description	Largest sub-index supported
Access	RO
PDO Mapping	No
Value Range	8
Default Value	8

Sub-Index	1h to 8h (X = 1 to 8)
Description	RTD X High Warning Temp.
Access	RW
PDO Mapping	No
Value Range	(RTD X Low Warning Temp + 100) to (RTD X High Shutdown Temp – 100)
Default Value	1250 [125°C]

3.4.14. Object 4020h: High Temperature Shutdown Threshold

This object sets the high threshold of the shutdown operating temperature range for each RTD's input field value (\$6100.) Any FV value above this limit flags a high shutdown in the corresponding RTD's status byte (\$6150), as well as setting an EMCY code in the pre-defined error field (\$1003). The data in sub-indexes 1 to 8 is interpreted with a fixed resolution of 0.1°C/bit.

Object Description

Index	4020h
Name	High Temperature Shutdown Threshold
Object Type	ARRAY
Data Type	INTEGER16

Entry Description

Sub-Index	0h
Description	Largest sub-index supported
Access	RO
PDO Mapping	No
Value Range	8
Default Value	8

Sub-Index	1h to 8h (X = 1 to 8)
Description	RTD X High Shutdown Temp.
Access	RW
PDO Mapping	No
Value Range	(RTD X High Warning Temp + 100) to 17350
Default Value	2500 [250°C]

3.4.15. Object 4030h: Error React Delay

This object defines the length of time during which a RTD's input field value must remain outside of the operating ranges as defined in objects \$4000, \$4010, and \$4020. Should the temperature go back within the acceptable range during this period, the fault will not be flagged in the status byte (\$6150), nor will an EMCY code be generated in the pre-defined error field (\$1003).

Object Description

Index	4030h
Name	Error React Delay
Object Type	ARRAY
Data Type	UNSIGNED16

Entry Description

Sub-Index	0h
Description	Largest sub-index supported
Access	RO
PDO Mapping	No
Value Range	8
Default Value	8

Sub-Index	1h to 8h (X = 1 to 8)
Description	RTD X Error React Delay
Access	RW
PDO Mapping	No
Value Range	0ms to 60000ms
Default Value	5000ms

3.4.16. Object 5000h: Power Supply Measured

This read-only object reflects the value, in volts, of the supply powering the scanner

Object Description

Index	5000h
Name	Power Supply Measured
Object Type	VAR
Data Type	FLOAT32

Entry Description

Sub-Index	0h
Access	RO
PDO Mapping	Yes
Value Range	8.0V to 60.0V
Default Value	No

3.4.17. Object 5001h: Current Source Measured

This read-only object reflects the value, in mA, of the current source multiplexed to each resistive input in order to generate a measurable voltage across the sensor.

Object Description

Index	5001h
Name	Current Source Measured
Object Type	VAR
Data Type	FLOAT32

Entry Description

Sub-Index	0h
Access	RO
PDO Mapping	Yes
Value Range	3.8mA to 4.2mA
Default Value	No

3.4.18. Object 5010h: ADC Filter Frequency

This object defined the filter cutoff frequency used by the 24-bit analog-to-digital converter.

Object Description

Index	5010h
Name	ADC Filter Frequency
Object Type	VAR
Data Type	UNSIGNED8

Entry Description

Sub-Index	0h
Access	RW
PDO Mapping	No
Value Range	50Hz or 60Hz
Default Value	60Hz

3.4.19. Object 5555h: Start in Operational

This manufacturer specific object allows the unit to start in Operational mode without requiring the presence of a CANopen ® Master on the network. It is intended to be used only when running the controller as a stand-alone module. This should always be set FALSE whenever it is connected to a standard master/slave network.

When set to TRUE, the unit will still power up in BOOT mode and send the pre-operation message. Five seconds later, the unit will automatically switch to OPERATIONAL mode, and start broadcasting the measured temperatures on the relevant TPDOs. The 5 second delay is to make sure that all data from all channels is read correctly and prevents sending erroneous data to the network after a power cycle.

Object Description

Index	5555h
Name	Start in Operational Mode
Object Type	VARIABLE
Data Type	BOOLEAN

Entry Description

Sub-Index	0h
Access	RW
PDO Mapping	No
Value Range	0 (FALSE) or 1 (TRUE)
Default Value	0 [FALSE]

4. USING RS-232 WITH TERA TERM

Additional information for diagnostics or testing is available through RS-232.

- Connect the DB-9 to a COM port on a PC or laptop. Use the following RS-232 connection.

8-Pin Connector		DB-9 Female	
Pin #	Controller Function	Pin #	PC Function
7	RS-232 Transmit	2	RS-232 Receive
8	RS-232 Receive	3	RS-232 Transmit
6	GND Reference	5	RS-232 GND

- Open Tera Term Pro, and set it up as shown in the steps below.
(Free downloadable from <http://logmett.com/index.php?/products/teraterm.html>)
- Select **Serial** with the appropriate COM port for your PC or laptop

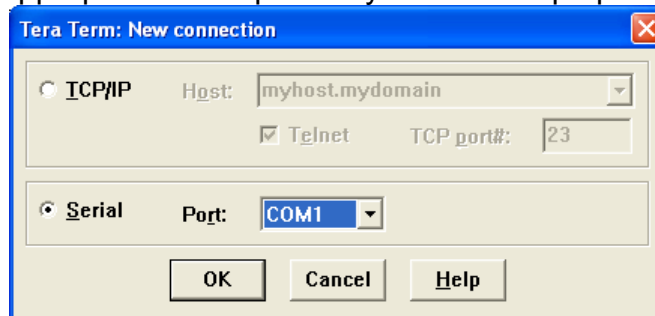

- Go to **Setup/Serial Port** and change the settings to exactly as shown below (other than Port)

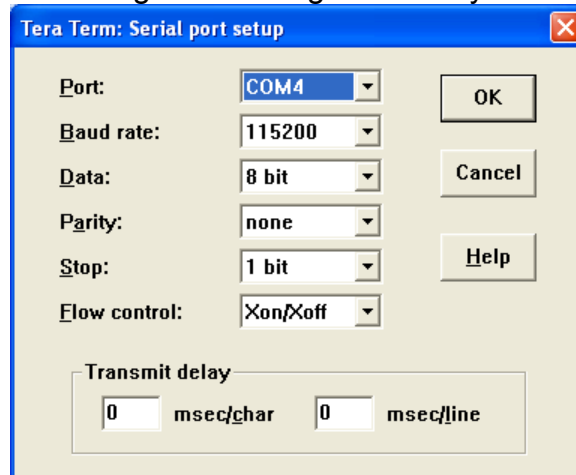

- Go to **Setup/Terminal** and verify that New-line Transmit and Receive are CR. The window size can be adjusted as desired by checking 'Term size = win size'

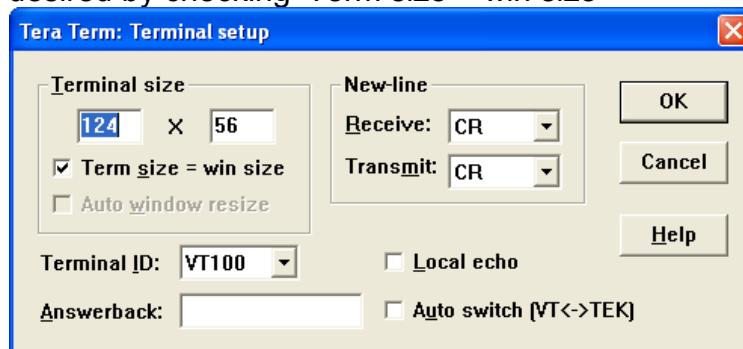

4.1. Main Menu Options

At power up, the Main Menu will be displayed, after the power up banner has been printed. If at any time you wish to see the menu again, simply hit 'm' or 'M' and it will be reprinted, along with the basic information about the CANopen ® network variables.

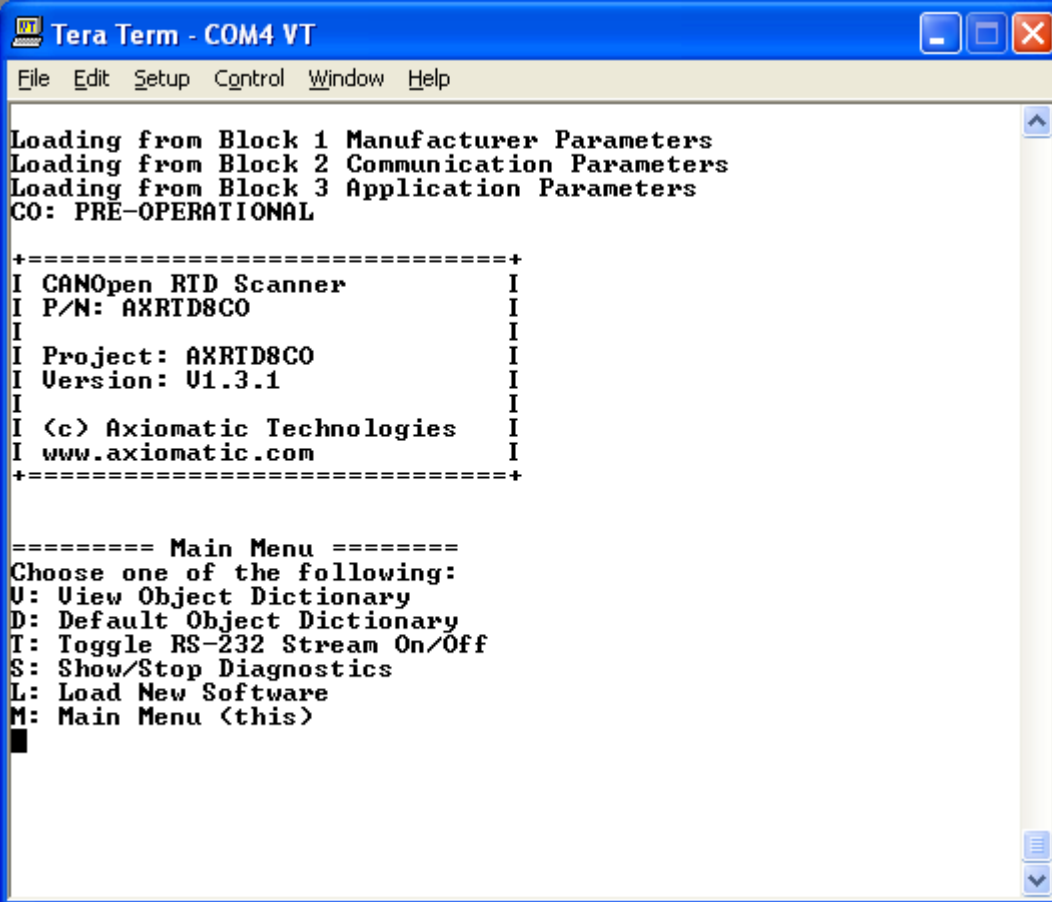

```
Tera Term - COM4 VT
File Edit Setup Control Window Help

Loading from Block 1 Manufacturer Parameters
Loading from Block 2 Communication Parameters
Loading from Block 3 Application Parameters
CO: PRE-OPERATIONAL

+-----+
| CANOpen RID Scanner          |
| P/N: AXRID8CO                |
|                               |
| Project: AXRID8CO            |
| Version: U1.3.1              |
|                               |
| (c) Axiomatic Technologies   |
| www.axiomatic.com           |
+-----+

===== Main Menu =====
Choose one of the following:
U: View Object Dictionary
D: Default Object Dictionary
T: Toggle RS-232 Stream On/Off
S: Show/Stop Diagnostics
L: Load New Software
M: Main Menu (this)
█
```

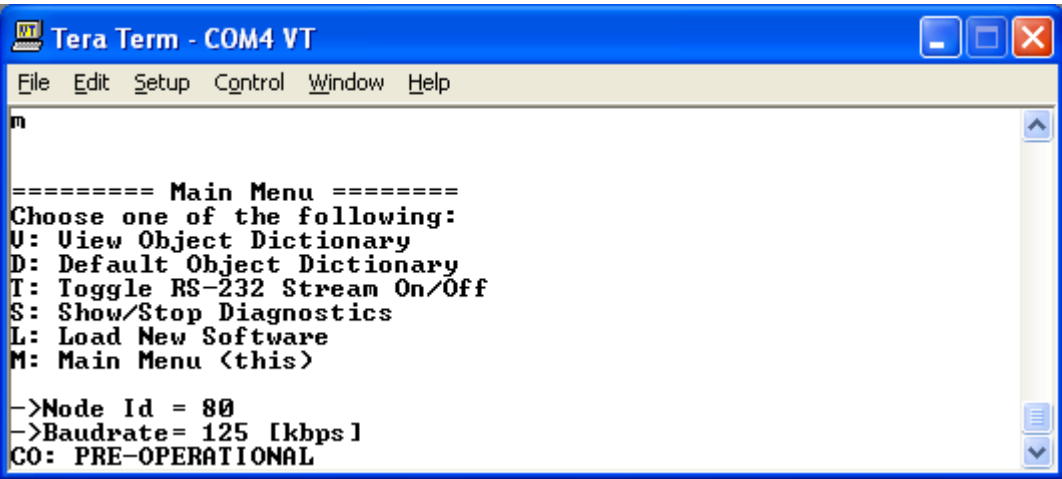

```
Tera Term - COM4 VT
File Edit Setup Control Window Help

m

===== Main Menu =====
Choose one of the following:
U: View Object Dictionary
D: Default Object Dictionary
T: Toggle RS-232 Stream On/Off
S: Show/Stop Diagnostics
L: Load New Software
M: Main Menu (this)

->Node Id = 80
->Baudrate= 125 [kbps]
CO: PRE-OPERATIONAL
```

4.1.1. V – View Object Dictionary

Entering 'v' or 'V' while the node is in the pre-operational state starts the display of the active Object Dictionary for the AXRTD8CO. Since it is too large to print in one shot, it will show the PDO communication and mapping parameters, then display each object one by one. To view the next object, simply hit the 'Enter' key. If at any time you would like to exit the loop, simply hit 'x' or 'X' and normal operation will resume.

WARNING: While in the view sub-menu, all other operations including temperature scanning and CAN networking are halted. Do not use this feature when regular operating conditions are required.

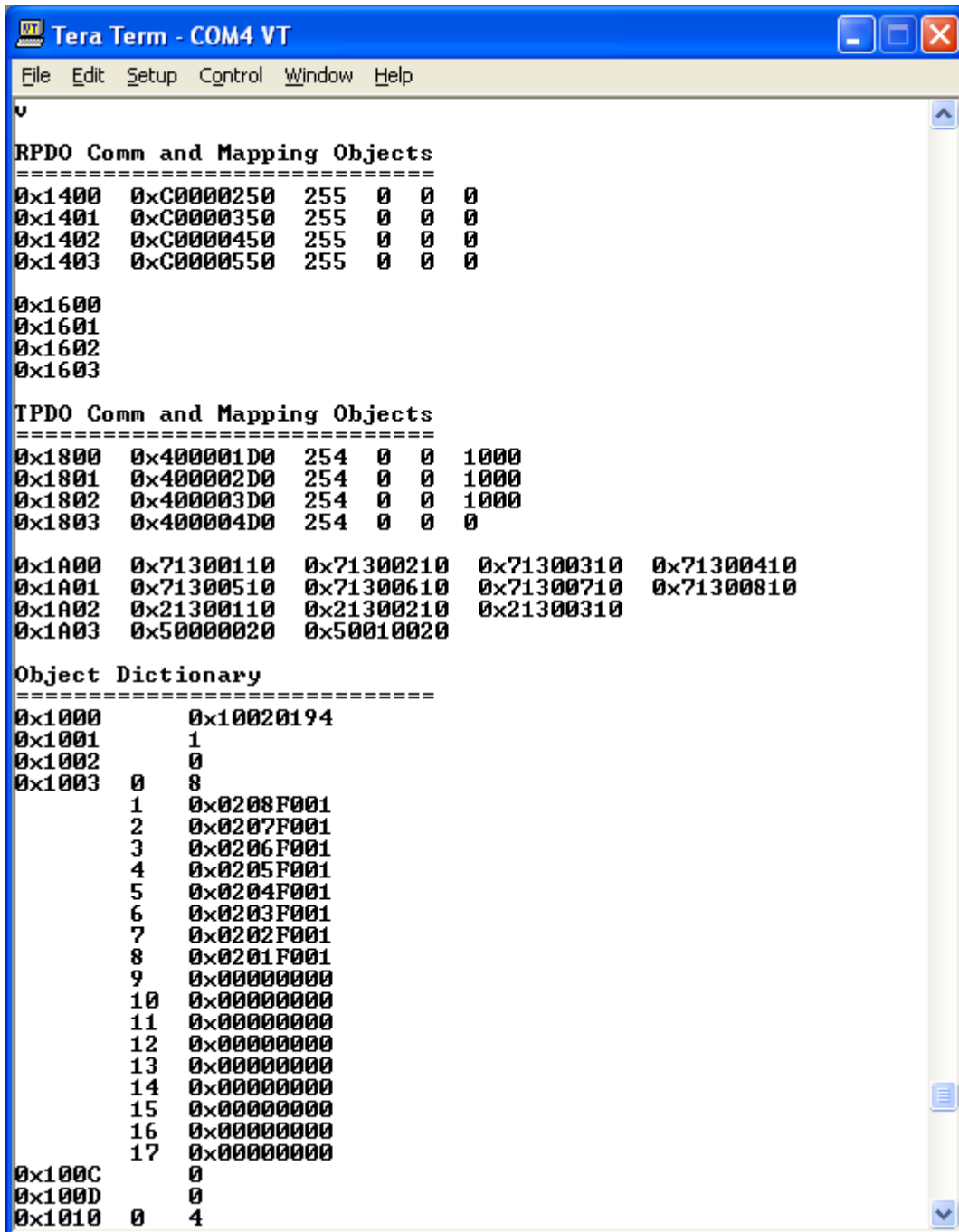

4.1.2. D – Default Object Dictionary

To reset the default Object Dictionary, enter 'd' or 'D'. At the prompt, enter 'Yes'. This function mirrors that of writing 'load' to Object 1011h, Restore Defaults. Consequently, it does not reset the Node-ID or Baudrate if they have been changed using LSS protocol. However, unlike the Restore Defaults object, these defaults will be immediately applied, as the controller automatically resets itself.

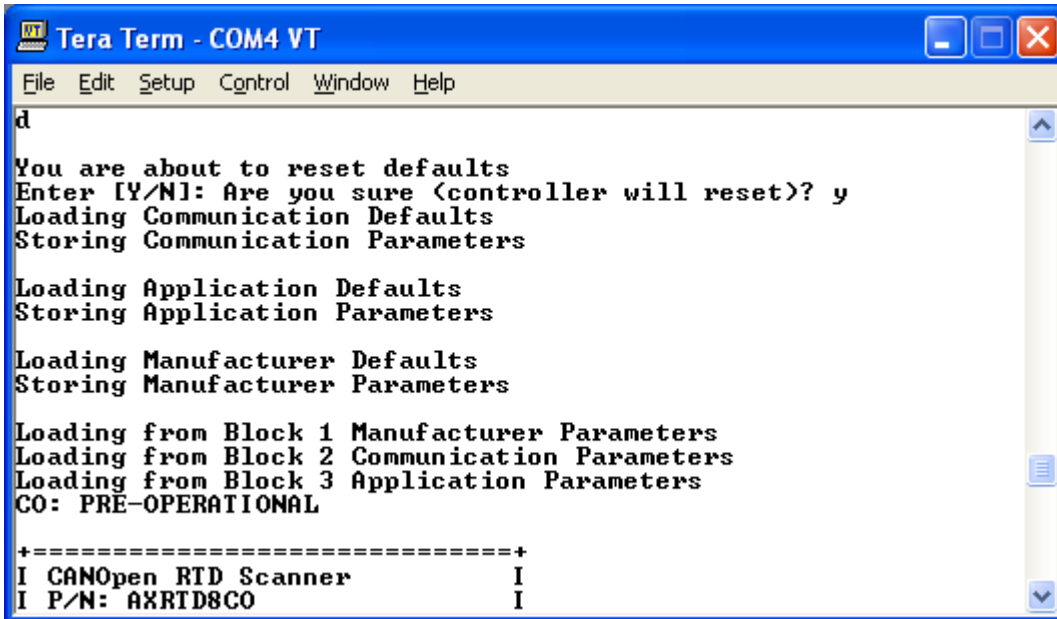

```
Tera Term - COM4 VT
File Edit Setup Control Window Help
d
You are about to reset defaults
Enter [Y/N]: Are you sure (controller will reset)? y
Loading Communication Defaults
Storing Communication Parameters

Loading Application Defaults
Storing Application Parameters

Loading Manufacturer Defaults
Storing Manufacturer Parameters

Loading from Block 1 Manufacturer Parameters
Loading from Block 2 Communication Parameters
Loading from Block 3 Application Parameters
CO: PRE-OPERATIONAL

+-----+
I CANOpen RTD Scanner      I
I P/N: AXRTD8CO            I
```

4.1.3. T – Toggle RS-232 Stream On/Off

In some applications, it may be desirable to be able to read or log data using RS-232. In these cases, this menu option enables the user to configure some basic variables associated with the RS-232 data stream. All configurations are automatically stored in non-volatile memory, and will still take effect after every power cycle. (i.e. once on, the data will always be sent until turned off).

The two variables that the user can change when selecting to toggle the data stream ON are:

- a) Whether the data sent will be the field value (object \$6100) or the Process Value (object \$7130)
- b) The repetition rate at which the data stream will be sent, in milliseconds.

The field width is fixed in all cases to 6 characters, and each temperature is delimited by a semi-colon. The order of the data is always sent as shown below.

RTD1;RTD2;...RTD7;RTD8

If a channel is not used (disabled by object \$6112), the entry will read "Null ". Alternatively, if the sensor is open circuited, the entry will read "Open ", and a short would read "Short".

An example of the RS-232 data stream that would be sent is shown on the next page.

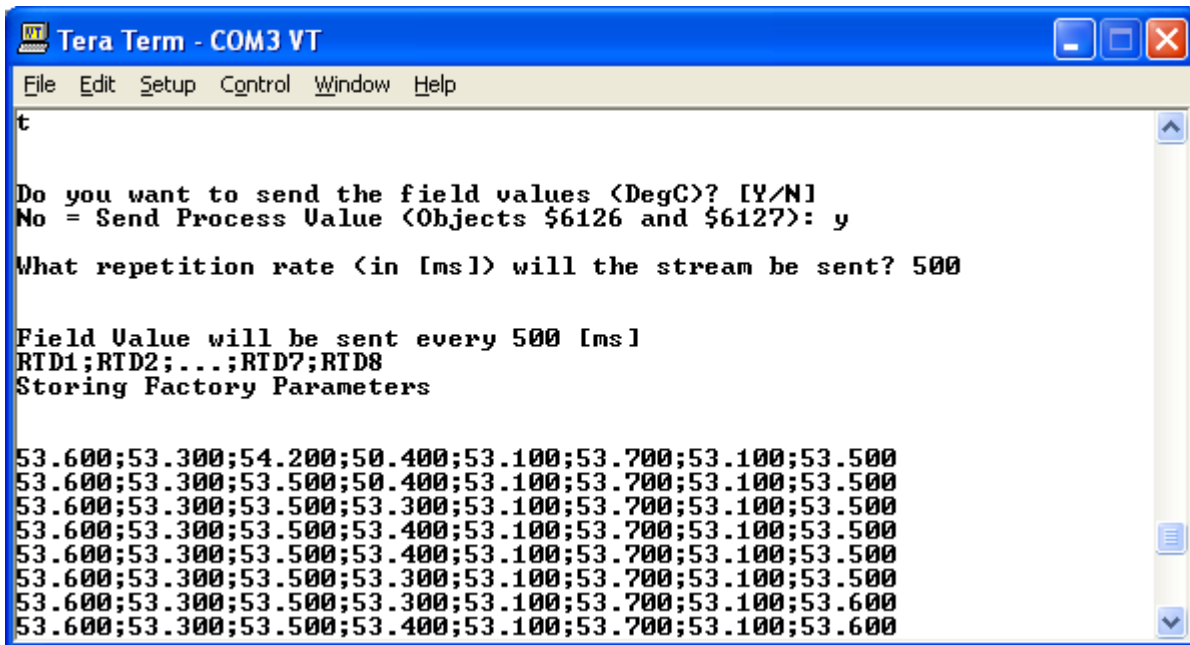

4.1.4. S – Show/Stop Diagnostics

Another diagnostic option is available using the 's' or 'S' option. Once started, the diagnostic screen will be refreshed every 1 second until stopped. Please note, this option is only for manual diagnostics, and is not saved in non-volatile memory (i.e. the diagnostic screen is never displayed after a power cycle without the 's' entry)

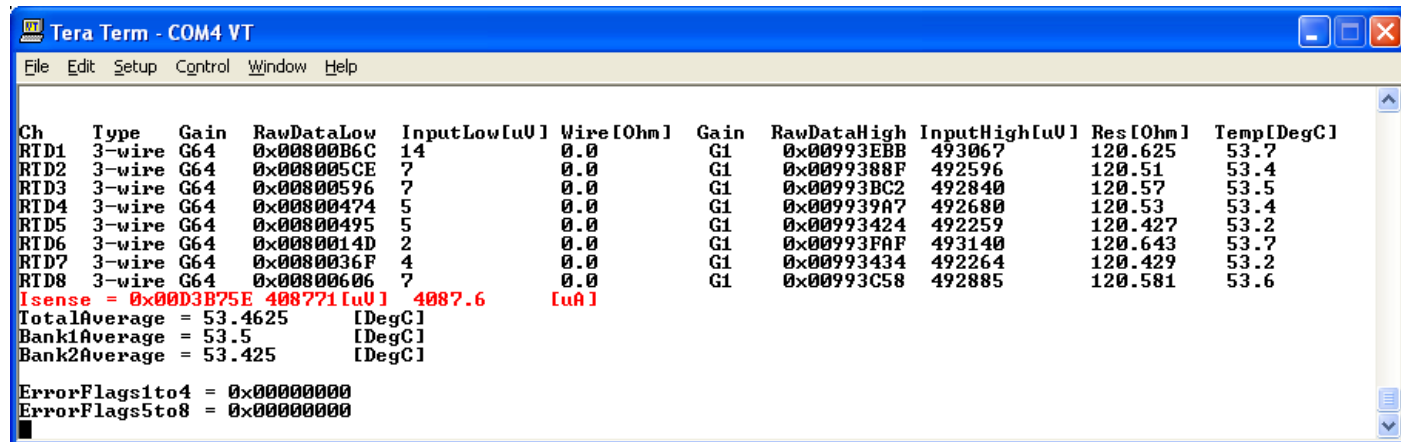

4.1.5. L – Load New Software

Should a software upgrade of the application software be required, the units can be reprogrammed by selecting this option. If Axiomatic has sent new software, select 'I' or 'L', and at the prompt enter the password that was provided by your Axiomatic contact.

Once the correct password has been entered (case-sensitive), the controller will automatically reset itself the bootloader header will be printed. At the prompt, hit any key (i.e. Enter) and wait for the message "Waiting for application S-Record" to be displayed. Go to **File/Send File** and send the AXRTD8CO_Vx.y.z.elf.S file sent by Axiomatic.

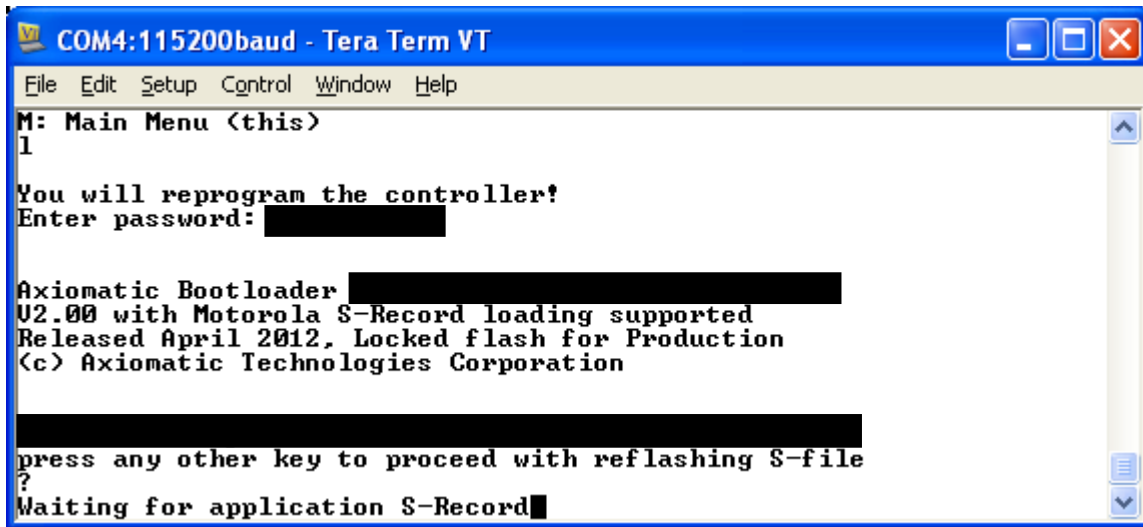

As the file uploads, a pop-up progress message will be shown, and the controller will print dots on the display. After the file has finished loading, the message “S-File has been loaded successfully” will be displayed, and the normal power-up messages will be printed. Verify the version number in the power-up banner matches that of the latest software.

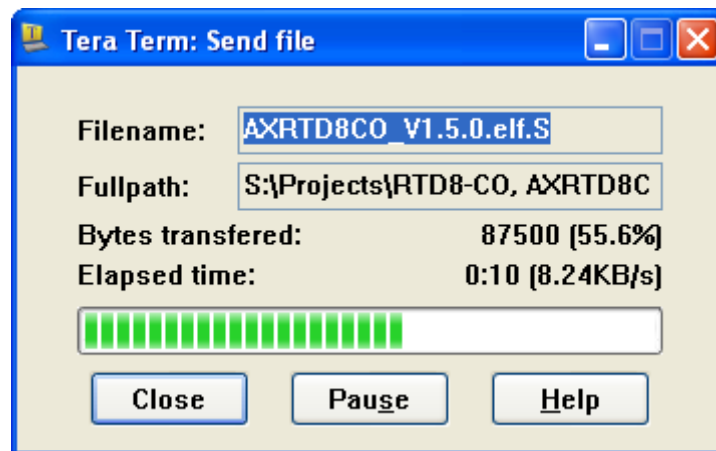

```
COM4:115200baud - Tera Term VT
File Edit Setup Control Window Help
?
Waiting for application S-Record
Starting S-Record upload.....
.....
.....
Loaded 76306 bytes.
Application started from address 0x000000AC

S-File has been loaded successfully
Restarting Bootloader

Loading from Block 1 Manufacturer Parameters
Loading from Block 2 Communication Parameters
Loading from Block 3 Application Parameters
CO: PRE-OPERATIONAL

+-----+
I CANOpen RTD Scanner      I
I P/N: AXRTD8CO            I
I                           I
I Project: AXRTD8CO        I
I Version: U1.5.0          I
I                           I
I (c) Axiomatic Technologies I
I www.axiomatic.com       I
+-----+

===== Main Menu =====
```

APPENDIX A – Technical Specifications

Inputs

Power Supply Input	12Vdc or 24Vdc nominal (9...32 VDC power supply range)
Supply Current	170 mA at 12 V Typical, 90 mA at 24 V Typical Inrush does not exceed 800 mA.
Protection	Reverse polarity protection is provided. Power supply input section protects against transient surges and short circuits and is isolated from RTD inputs
RTD Types	Up to 8 channels, independently configurable for 2, 3 or 4 wire RTDs. Each channel independently supports specific sensors IEC 0.00385, JIS 0.003916, US 0.003902, Legacy 0.003920, SAMA 0.003923. A user defined coefficient would enable custom Callendar-Van Dusen constants to be set for sensors not listed above.
RTD Inputs	The device accepts inputs within the following range of 10 - 350 Ohms. "Short Circuit" condition is triggered when the sensor resistance is below 5 Ohm. "Open Circuit" condition is reported when the sensor resistance exceeds approximately 600 Ohm. Accuracy: +/- 1°C typical at ambient temperature Resolution: 0.1°C Isolation voltage is 1500 Vac (rms) or 2550V for 1 sec.
Scan Rate	100ms per channel, total sweep time maximum 900 ms
Common Mode Readings	Input range +/- 4V maximum Rejection is 100db at 5Vp-p (50-60Hz)
Thermal Drift	Overall drift with temperature is 15mOhm/°C (maximum)
Isolation	Digital isolation is 500VDC from input to ground. Three way isolation is provided for the CAN line, inputs and power supply
Averaging	Available on Bank 1 (RTD1-RTD4), Bank 2 (RTD5-RTD8) and Total (All)
Protection	Open or short circuit detection, Frozen data detection Over or under temperature detection, High temperature shutdown detection

Communication

CAN	1 CAN 2.0Bport, protocol CiA CANopen ® By default, the RTD Scanner transmits the process value (object \$7130) according to the device profile in CiA Standard DS-404
RS-232	1 RS-232 port available, ASCII Text Format, 115200 Baud Rate Data – 8 bit, Parity – None, Stop – 1 bit. Flow Control – Xon/Xoff. Short circuit protection to ground.

General Specifications

Microprocessor	16-bit, 512 KByte flash program memory
Control Logic	User programmable functionality using SDO object access, per CiA DS-301
User Interface	.EDS provided to interface to standard CANopen ® tools Go to the Log-in tab on www.axiomatic.com . Request to password from sales@axiomatic.com.
UL and cUL Compliance	UL508 (April 2010) (FTPM2) – Controls for Stationary Engine Driven Assemblies cUL C22.2 No. 14-10 (2010)
CE Compliance	2004/108/EC (EMC Directive) 2011/65/EU (RoHS Directive)
Vibration	11.48 G for a device rigidly mounted to a generator housing <i>The marine type approval process tested to 4.0 G per IEC 60068-2-6, Test Fc.</i>
Marine Type Approval	Lloyd's Register, DNV, ABS, RINA, GL, BV, CCS, IRS, RS <i>The AXRTD8CO meets the environmental, EMC and vibration requirements of generator set applications in marine installations.</i>
Operating Conditions	-40 to 85 °C (-40 to 185 °F)
Storage	-50 to 120 °C (-58 to 248 °F)
Humidity	Protected against 95% humidity non-condensing, 30°C to 60°C.
Enclosure	Rugged aluminum housing, stainless steel end plates, neoprene gaskets 145.30 x 149.00 x 73.00 mm (5.72 x 5.86 x 2.87") L x W x H Connectors, Deutsch IPD P/N: 1 8-pin DT13-08PA, 1 40-pin DRC13-40PA
Protection	IP67 rating, Pollution Degree 3 per UL508 <i>The marine type approval process tested to IP56.</i>
Weight	2.2 lbs. (1.00 kg)